



INSTALLATION INSTRUCTIONS

BRUSHLESS SINGLE FAN POWERPACK WITH PWM

PART # 67922 & 67923

Please read these instructions completely before beginning installation

FAN SHROUD ASSEMBLY KIT CONTENTS

QTY.	DESCRIPTION	QTY.	DESCRIPTION	QTY.	DESCRIPTION
1	Brushless Fan Shroud Assembly	1	50 AMP Circuit Breaker	16	1/4-20 SS Lock Nuts
1	PWM Fan Sensor/Control	1	3ft of 10 AWG Red Wire	40	1/4" SS Flat Washers
1	Sensor Wiring Harness SBL-TS-HARN	4	Angle Brackets	2	Yellow 5/16" Ring Terminal
1	Fan Wiring Harness SBL-YAZ-PT	1	Rubber Fan Shroud Seal	2	Yellow #10 Ring Terminal
		16	1/4-20 x 3/4" SS Hex Bolts	1	Red Butt Connector

TOOLS NEEDED

- Drill
- 5/32" Drill Bit
- Multimeter / Test Light
- 5/16" Nut Driver
- 7/16" Open End Wrench
- 7/16" Socket & Ratchet
- Wire Stripper
- Wire Crimping Tool
- Thread Sealant

IMPORTANT

This fan assembly is designed for PULLER APPLICATIONS ONLY Engine side of radiator. (See Diagram #1)

Diagram #1

Down Flow Radiator

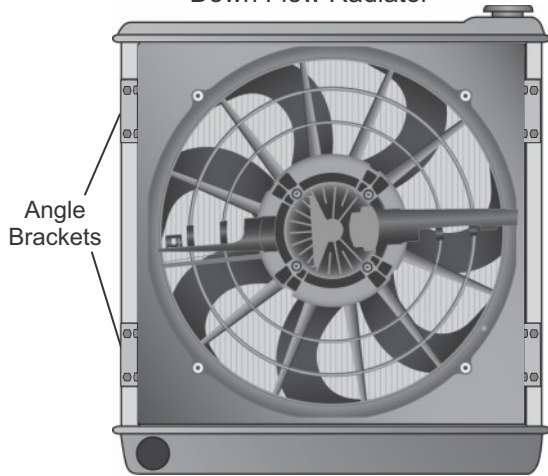

MOUNTING OPTIONS

Cross Flow Radiator

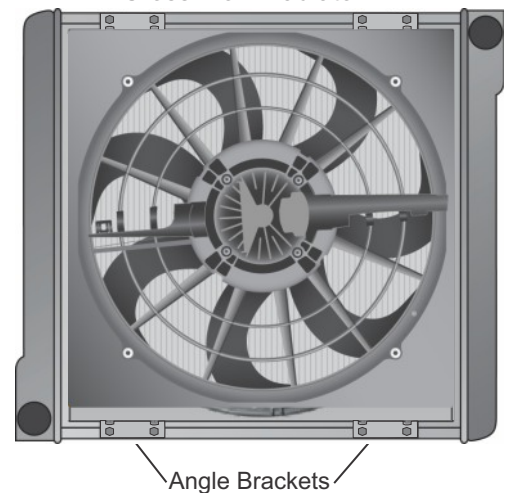

Shroud should be mounted tight against radiator to minimize air leaks that would reduce efficiency.

Diagram #2

Option 1
Flush Mount

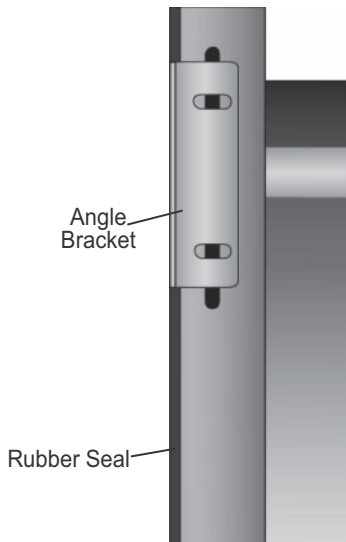

Option 2
Recessed Mount

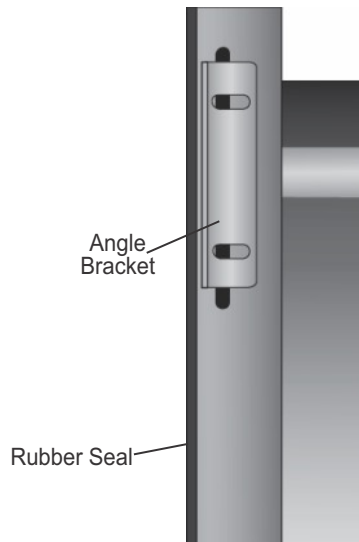

Adjustment Range

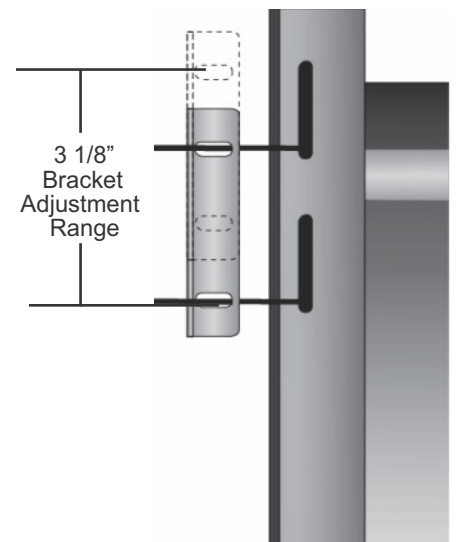

INSTALLATION

PWM SENSOR CONTROL PROBE INSTALLATION

Note: The sensor thread size is 3/8-18 NPT

1. Locate a water port on the HOT side of the vehicles cooling system. (Intake Manifold, Thermostat Housing, Radiator, etc.) In some cases the vehicle will not be equipped with a 3/8 port, if this is the case you can use an adapter/bushing (preferably Brass) to accommodate a 1/2" NPT port. When adapting the sensor to 1/2" NPT, make sure the unthreaded portion of the sensor is still able to make good contact with the coolant.
2. Apply a suitable Thread Sealant to sensor threads/adapter threads.
3. Install the PWM sensor into the port and tighten. This is a tapered thread, so be sure not to overtighten.
4. At this time, continue to the INSTALLATION OF ELECTRIC FAN ASSEMBLY TO RADIATOR section, you will complete the sensor installation when you get to the wiring section.

Diagram #3

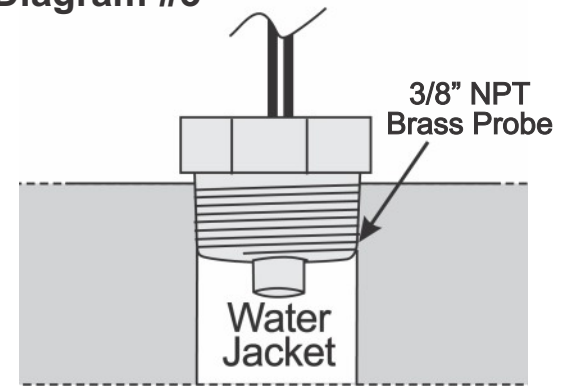

INSTALLATION OF ELECTRIC FAN ASSEMBLY TO RADIATOR

Before installing shroud Reference Diagrams # 1 & 2 on page 1 to decide how the Assembly should be mounted to radiator.

1. Using a table or workbench, lay the Brushless Fan Shroud Assembly on a flat surface, fan facing down.
2. Take the supplied Rubber Fan Shroud Seal and install it onto the bottom edge of the Fan Shroud Assembly. (See Diagram #4)
3. Cut off any excess Rubber.
4. Identify the four Angle Brackets, Stainless Steel 1/4-20 x 3/4" Hex Bolts, 1/4" Flat Washers & 1/4-20 Lock Nuts.
5. Attach the Angle Brackets to the Shroud using two bolts per bracket. (See Diagram #4)
Note: In some applications where the radiator flange is not right up against the fan shroud, longer bolts can be used to space the Angle Brackets. (See Diagram #5) Hardware not included.
6. Position the Electric Fan Assembly against the radiator in the desired location.
7. Using the remaining Stainless Steel 1/4-20 x 3/4" Hex Bolts, 1/4" Flat Washers & 1/4-20 Lock Nuts, attach the Electric Fan Shroud Assembly to the radiator. (See Diagram #5)

Note: In some cases the radiator flange may have to be drilled for proper alignment.

Diagram #4

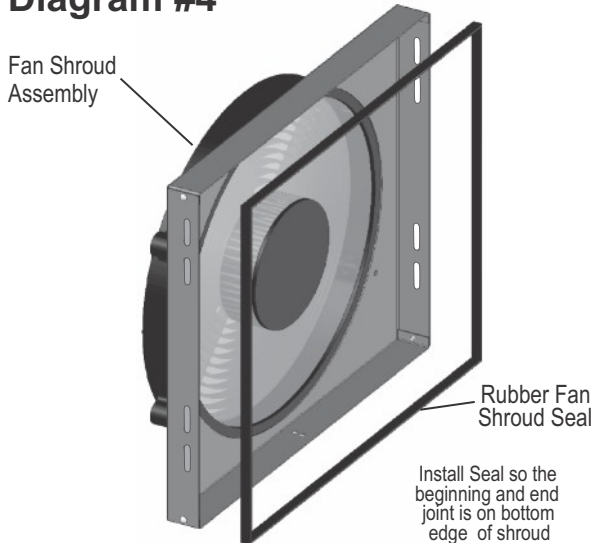

Diagram #5

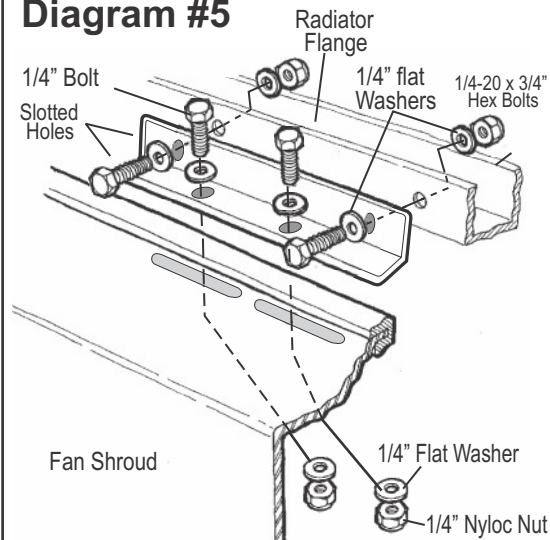
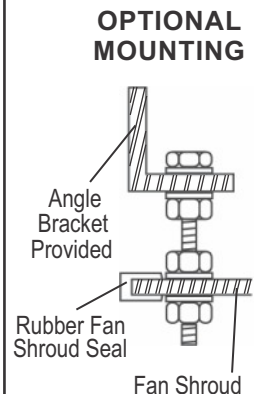

Diagram #6



CIRCUIT BREAKER MOUNTING

1. Choose a convenient location for the circuit breaker that is between the fan controller and the battery.
2. Using the circuit breaker as a template, mark and drill two 5/32" holes in the proper locations.
3. Using the remaining two #10 sheet metal screws supplied, secure the circuit breaker in place.

FAN WIRING INSTRUCTION

Before starting, disconnect the negative (-) cable on the vehicles battery.

Using the Wire Harness, Wire & electrical connectors provided, follow the instructions below.

IMPORTANT: The positive and negative wires feeding the Fan Wiring Harness (SBL-YAZ-PT) **MUST** be connected directly to the vehicles battery. This is very important because the Fan requires a clean signal, do not connect directly to the fuse panel, starter or the alternator. **Improper installation will void the warranty.**

Note: The supplied Terminals and Connectors are crimp and seal terminals. After crimping the Terminal(s) and Connector(s) to the inserted wires, apply heat to shrink the insulation material to the wires using a heat gun. When heat is applied to the shrink material it will shrink and seal the wires going into the Terminal(s) and Connector(s).

1. Plug the provided Fan Wiring Harness (SBL-YAZ-PT) into the blue plug on the fan motor (See Diagram #7).
2. Using a Yellow 5/16" Ring Terminal & 3ft of 10 AWG Red Wire (supplied), connect one end of the Red Wire to the vehicles positive (+) terminal on the battery.
3. Route the 10 AWG Red Wire now connected to the battery to the circuit breaker previously installed and cut the wire to the appropriate length.
4. Using a yellow #10 ring terminal, connect the 10 AWG Red Wire to the "BAT" (Copper Colored) terminal on the circuit breaker.
5. Using a yellow #10 ring terminal, connect the auxiliary side "AUX" (Silver Colored) of the circuit breaker to the Red Wire of the Fan Wiring Harness (SBL-YAZ-PT).
6. Using a Yellow 5/16" Ring Terminal, Connect the Black Wire from the Fan Wiring Harness (SBL-YAZ-PT) direct to Battery Ground terminal. (See Note above)
7. Using a Red Butt connector connect the White Wire from the Fan Wiring Harness (SBL-YAZ-PT) to the White Wire on the Sensor Wiring Harness (SBL-TS-HARN).
8. Connect Sensor Wiring Harness (SBL-TS-HARN) to the easy plugin connector on the PWM Fan Sensor/Control.
9. Connect the Red Wire from the Sensor Wiring Harness (SBL-TS-HARN) to a fused switched ignition source (fuse not provided).
10. Optional override Blue Wire from the (SBL-TS-HARN) connect to a 12V positive source for manual switch or A/C override.
11. Connect Black Wire from Sensor Wiring Harness (SBL-TS-HARN) to good chassis ground.
12. Yellow wire - DO NOT USE! Yellow Wire will not be used from Fan Wiring Harness (SBL-YAZ-PT).
13. After Fan installation check all connections. Connect the negative (-) cable on the vehicles battery.

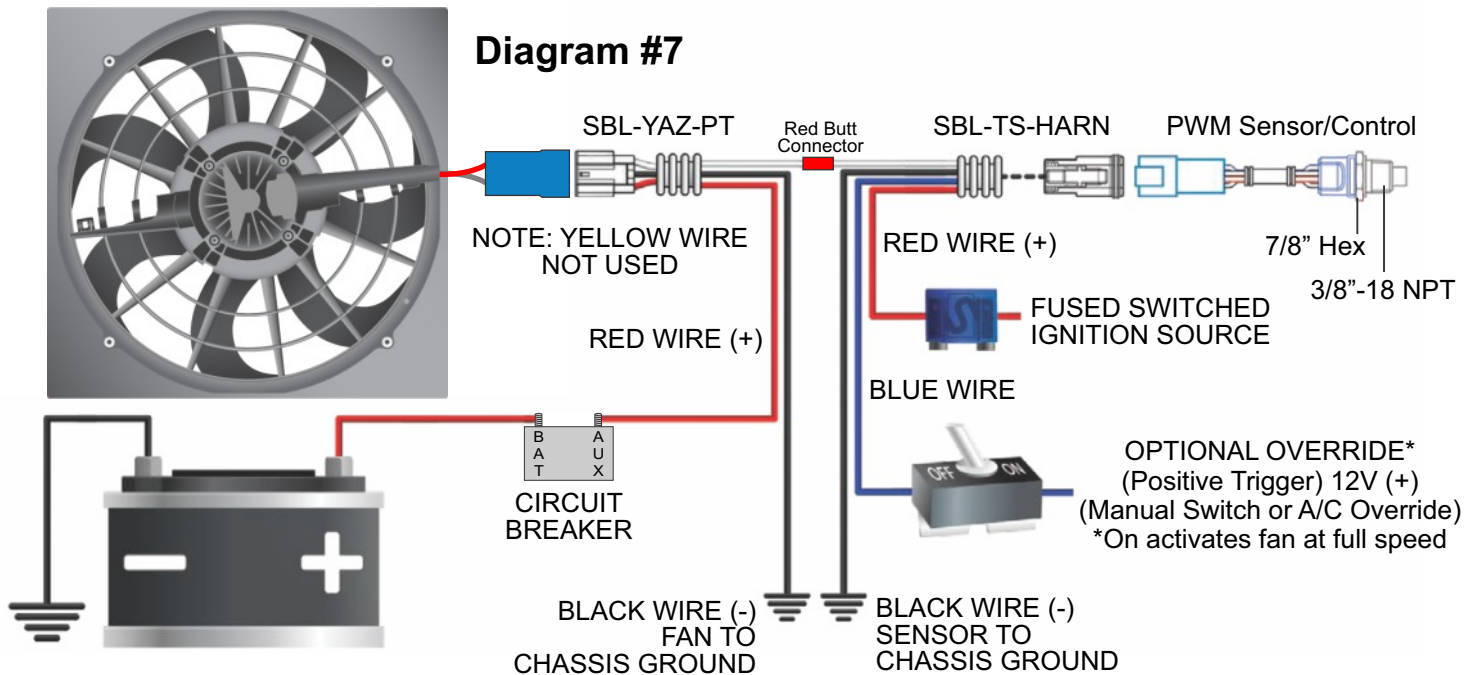

(Page 3)

STOP Please direct all technical questions to our Derale tech line at (323) 266-3850 **STOP**

Warning: Installation of accessories should only be undertaken by those with mechanical knowledge and are familiar with working on vehicles. Always use eye protection (goggles, safety glasses or shield). Park the vehicle in a well lit area, on level ground and apply the parking brake. Only work on a cold vehicle that has been sitting overnight, failure to do so will result in severe burns and injury. Before starting the vehicle, make sure no tools or any other items are left under hood that could interfere with or be drawn into moving parts of the engine. Failure to follow instructions can lead to severe damage and personal injury.

Derale Performance, Los Angeles, CA • 323.266.3850 • www.derale.com