



INSTALLATION INSTRUCTIONS PREMIUM REMOTE FILTER MOUNT PART # 35707 & 35727

Please read these instructions completely before beginning installation

KIT CONTENTS

QTY.	DESCRIPTION
2	Ports Left/Right Filter Mount
2	Filter Nipple
8	1/4-20 x 3/4" Socket Cap Bolt
8	1/4-20 x 3/8" SS Button Head Bolt
4	-10 AN / 7/8-14 O-ring Aluminum Plug
1	7/8-14 O-ring Swivel Adapter

IMPORTANT

The Filter Mounts are machined with -10 AN / 7/8-14 threaded ports & MUST have an O-ring style fitting. Derales offers several Aluminum AN Male Adapter Fittings, please visit www.derales.com or visit your local retailer.
Note: O-ring fittings DO NOT require thread sealant.

TOOLS NEEDED

- Open End Wrenches
- Allen Wrenches
- Oil Filter Wrench

INSTALLATION

- Identify the eight 1/4-20 x 3/4" Socket Cap Bolts, Mounting Brackets and Filter Mounts.
- Using an Allen Wrench, attach the Mounting Brackets to the Filter Mounts making sure that one bracket is mounted on the "OUT PORT" side of the first Filter Mount and the second bracket mounted to the "IN PORT" side of the second filter mount.

Note: Loctite or suitable sealant can be used for a permanent application. The four mounting holes opposite the mounting brackets can also be used for additional mounting in severe duty installations.

- Identify the eight 1/4-20 x 3/8" SS Button Head Bolts, these are included for aesthetic purposes to plug the holes on the front side of the Filter Mount. They serve no other function. (See Diagram #1)

- Using an Allen Wrench, attach and tighten.
- Identify the Aluminum Swivel Adapter.

- Install the Swivel Adapter on one filter mount on the furthest port opposite the Mounting Bracket. See Diagram # 1. Once you have determined the "IN" and the "OUT" Port that best fits your application, install the Swivel Adapter one side of one of the Filter mounts. (See Diagram #1)

- Identify two -10AN / 7/8-14 Aluminum Plugs. Install one plug in the port adjacent to the Swivel Adapter previously installed. Install the second Plug into the second Filter Mount port opposite of the Plug previously installed. See Diagram # 1.
- You can now attach the second filter mount to the -10AN / 7/8-14 Swivel Adapter already attached to the first filter mount. (See Diagram #1)
- Identify the two remaining -10AN / 7/8-14 Aluminum Plugs. Once you have determined the IN/OUT ports that best fit your application, install the two plugs into the unused ports. (See Diagram #1)

Note: The unused ports can be used for the vehicles Sending units, such as Temperature, Pressure, etc.

- Identify the supplied Filter Nipple.
- Carefully thread the nipples clockwise onto the Filter Mounts until it completely bottoms out.
- Install the Oil Filters onto the Filter Mounts.

Diagram #1

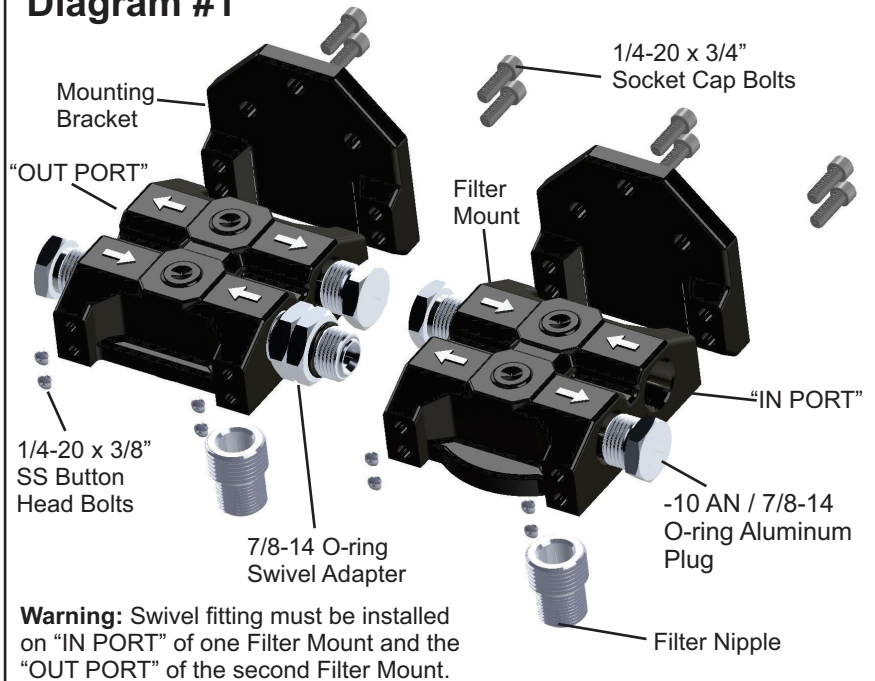

PART #	THREADS	FRAM	FRAM
		STANDARD	HI-PERFORMANCE
35707	3/4-16	PH8A	HP1
35727	13/16-16	PH13	HP4

Warning: Installation of accessories should only be undertaken by those with mechanical knowledge and are familiar with working on vehicles. Always use eye protection (goggles, safety glasses or shield). Park the vehicle in a well lit area, on level ground and apply the parking brake. Only work on a cold vehicle that has been sitting overnight, failure to do so will result in severe burns and injury. Before starting the vehicle, make sure no tools or any other items are left under hood that could interfere with or be drawn into moving parts of the engine. Failure to follow instructions can lead to severe damage and personal injury.