



# INSTALLATION INSTRUCTIONS FLUID CONTROL MOUNTING BRACKET PART # 25793

Please read these instructions completely before starting the installation.

## KIT CONTENTS

QTY.	DESCRIPTION
1	Mounting Bracket
4	1/4-20 x 3/8" Stainless Bolts
4	#14 Sheet Metal Screws

## TOOLS NEEDED

Allen Wrench	Marker
Drill	
3/16" Drill Bit	
Standard Screw Driver	

## MOUNTING LOCATION

Choose a convenient location on the vehicles frame, firewall, core support or sub frame.

## INSTALLATION

1. Using the four 1/4-20 x 3/8" Stainless Bolts, attach the Mounting Bracket to the fluid control thermostat in the desired orientation. (See Diagram #1)

**NOTE:** Loctite or suitable sealant can be used for a more permanent installation.

2. Using the Mounting Bracket Assembly as a template, mark and drill four 3/16" holes in the desired location.

3. Using the four #14 Sheet Metal Screws, attach the Mounting Bracket Assembly.

## Diagram #1

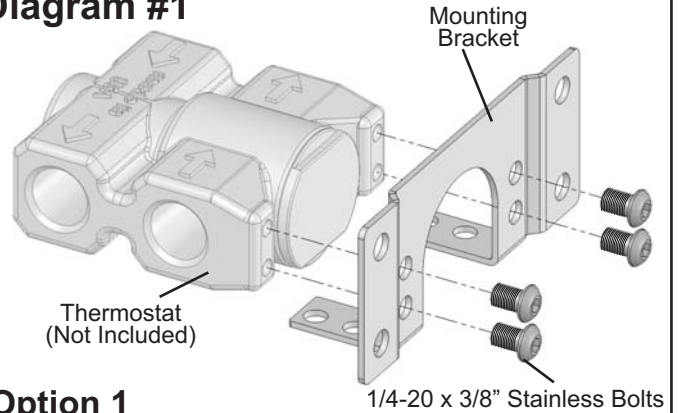

## Option 1

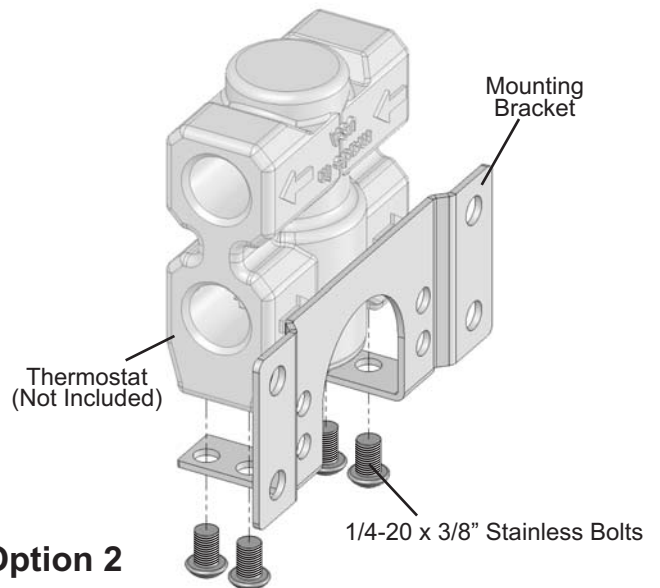

## Option 2

**Warning:** Installation of accessories should only be undertaken by those with mechanical knowledge and are familiar with working on vehicles. Always use eye protection (goggles, safety glasses or shield). Park the vehicle in a well lit area, on level ground and apply the parking brake. Only work on a cold vehicle that has been sitting overnight, failure to do so will result in severe burns and injury. Before starting the vehicle, make sure no tools or any other items are left under hood that could interfere with or be drawn into moving parts of the engine. Failure to follow instructions can lead to severe damage and personal injury.