



# INSTALLATION INSTRUCTIONS OIL FILTER RELOCATION KIT PART # 15715, 15717, 15718 & 15725

Please read these instructions completely before beginning installation

## KIT CONTENTS

QTY.	DESCRIPTION	QTY.	DESCRIPTION
1	Spin-On Adapter	1	Snap Ring
1	Ports Up Filter Mount	10ft.	1/2" Hose
1	O-ring (Spin-On Adapter)	4	1/2" NPT x 1/2" Hose Barb
1	3/4-16 Filter Nipple	4	Hose Clamps
1	Hex Sleeve Nut	3	#14 Sheet Metal Screws

## TOOLS NEEDED

7/8" Open End Wrench  
Standard Screw Driver  
Drill  
3/16" Drill Bit  
Teflon Tape

## PART # THREAD SIZE

<b>15715</b>	3/4"-16
<b>15717</b>	18mm x 1.5
<b>15718</b>	20mm x 1.5
<b>15725</b>	22mm x 1.5

## IMPORTANT

The new Filter Mount is designed to accept a 3/4-16 oil filter (Typical Ford filter) Use Derales Part # 13092 or reference chart on reverse for manufacturers part numbers.

## PRE-INSTALLATION

1. Remove the factory oil filter and clean the oil filter landing surface on the engine block.
2. Take the four 1/2" NPT x 1/2" Hose Barbs supplied. Using a Teflon Tape or suitable sealant, install two 1/2" NPT x 1/2" Hose Barbs onto the Spin-On Adapter. Install the remaining two 1/2" NPT x 1/2" Hose Barbs onto the Ports-Up Filter Mount.
3. Take the Hex Sleeve Nut and slide it into the Spin-on Adapters hex feature. Sleeve Nut will only install correctly in one direction. (See Diagram #1)
4. Take the supplied Snap Ring and carefully install into the snap ring groove of the casting making sure it is securely fastened. (See Diagram #1)

## INSTALLATION

### Spin-On Adapter

1. Apply a light coat of oil onto the O-ring.
2. Take the O-ring and install into the groove on the Spin-On Adapter.
3. Install onto the engine. (See Diagram #2)
4. Hand Tighten with the same force used in tightening a factory oil filter.

### Filter Mount

5. Choose a convenient location for the Ports-Up Filter Mount. Make sure there is enough space for future servicing of the oil filter. Suggested Locations: Firewall, Radiator Support, Fender well
6. Take the 3/4-16 Filter Nipple supplied, making sure the shorter end of threads is installed onto the Ports-Up Filter Mount. (See Diagram #3 on page 2)
7. Using the filter mount as a template, mark and drill three 3/16" holes.
8. Using the #14 Sheet Metal Screws provided, install the Ports-Up Filter Mount onto the vehicle.
9. Using the Hose Clamps provided, attach both ends of the 1/2" Hose provided to the hose barbs on the installed Spin-On Adapter forming a loop.
10. Carefully route hose over to the Ports-Up Filter Mount.

**Note:** Keep hoses away from sharp edges, moving parts and

## Diagram #1

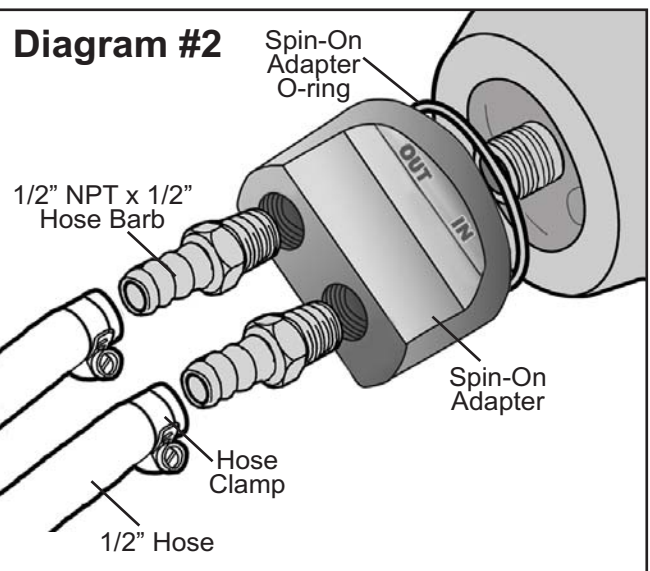
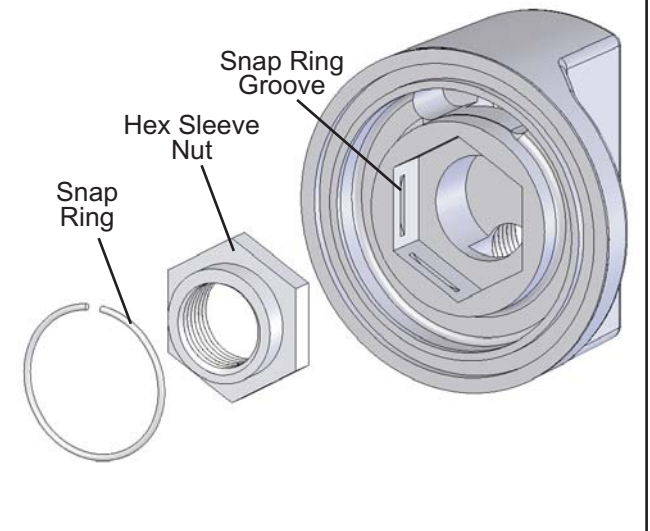

(Continues on Page 2)

exhaust. Do not bend hose sharper than a 5" radius.

11. Cut the hose to the proper length.
12. Using the Hose Clamps provided, attach the hose coming from the OUT on the Spin-On Adapter to the IN on the Ports-Up Filter Mount.
13. Using the Hose Clamps provided, attach the hose coming from the IN on the Spin-On Adapter to the OUT on the Ports-Up Filter Mount.
14. Apply a light coat of oil onto the o-ring of your new oil filter and install on the filter mount.

### **VEHICLE TESTING**

1. Start the engine and quickly check all connections for leaks.
2. Turn-off the engine and check the oil.
3. Add oil as needed.

<b>OIL FILTER CHART</b>	
<b>BRAND</b>	<b>PART #</b>
AC	PF2
Fram	PH8A
Motorcraft	FL1A
Purolator	PER1A

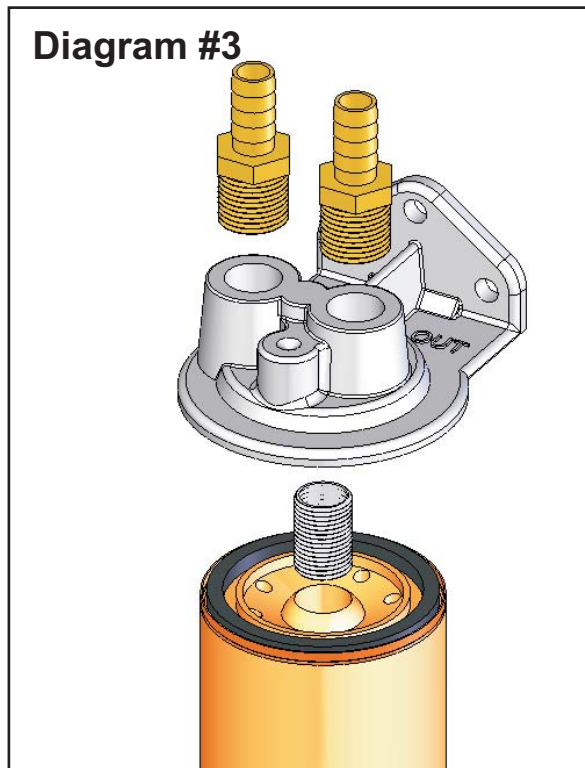

(Page 2)

**Warning:** Installation of accessories should only be undertaken by those with mechanical knowledge and are familiar with working on vehicles. Always use eye protection (goggles, safety glasses or shield). Park the vehicle in a well lit area, on level ground and apply the parking brake. Only work on a cold vehicle that has been sitting overnight, failure to do so will result in severe burns and injury. Before starting the vehicle, make sure no tools or any other items are left under hood that could interfere with or be drawn into moving parts of the engine. Failure to follow instructions can lead to severe damage and personal injury.