



# INSTALLATION INSTRUCTIONS ENGINE OIL COOLER KIT PART # 15503

Please read these instructions completely before starting the installation.

### KIT CONTENTS

QTY. DESCRIPTION	QTY. DESCRIPTION
1 Oil Cooler	4 Hose Clamps
1 Sandwich Adapter	1 13/16-16 Sleeve Nut
1 3 1/8" O-ring	4 Mounting Rods
2 1/2" NPT x 1/2" Barb Fittings	4 Foam Pads
10ft 1/2" OEM Spec Hose	4 Mounting Clips
5 6" Zip Ties	

### TOOLS NEEDED

Standard Screw Driver or 5/16" Nut Driver	11/16" Open End Wrench
Dyke Pliers	Oil Filter Wrench
Torque Wrench	1 1/8" Socket
	Thread Sealant Tape

### IMPORTANT

This kit is designed to fit GM vehicles Manufactured between 1963-2007 with engine block oil filter landings of 3 1/2", primarily SB & BB V8's. For vehicles with 2 1/2" and 2 3/4" oil filter landings, please visit [www.derale.com](http://www.derale.com) for alternative Sandwich Adapter Kits.

### COOLER LOCATION

When selecting the best location for your vehicle, always consider a location that will deliver the maximum airflow.

The Oil Cooler can be mounted in multiple locations on your vehicle. Reference Diagram # 1 for possible cooler positions. #1 is the ideal location, #2 is second best and #4 being the last choice.

**Note:** The Cooler core will flow in either direction, there is no specified inlet or outlet port.

### PRE-INSTALLATION

1. Slide one hose clamp on each end of the supplied Hose.
2. Using a dab of oil lubricate each end of the hose and install hose onto the 1/2" inlets on the Oil Cooler forming a loop.
3. Secure in place using the Hose Clamps. (See Diagram #2)

**Diagram #1**

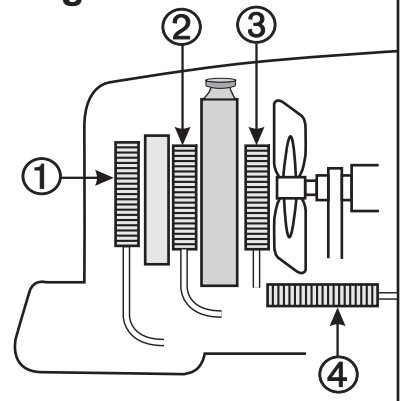

### COOLER MOUNTING

(See Diagram #2)

1. Identify the 4 Mounting Rods, 4 Mounting Clips and 4 1x1 Foam Pads.
2. One by one, Install the 4 Mounting Rods thru the Oil Cooler.
3. Take the 1x1 Foam Pads supplied, peel off the paper lining and slide them onto the Mounting Rods, sticking them against the Oil Cooler.
4. Take the Cooler Assembly with attached looped hose and hold in the desired location.
5. Install the 4 Mounting Rods thru the Radiator/Condenser core.

**Warning:** Do not use excessive force when pushing the Mounting Rods through the Radiator/Condenser. Excessive force could cause damage to the fins and possibly puncture a tube.

6. Take the Mounting Clips supplied, making sure they are in the correct direction (Derales writing out) install onto the Mounting Rods and cinch them until the 1x1 Foam Pads are slightly compressed.
7. Cut off any excess Mounting Rods.

**Diagram #2**

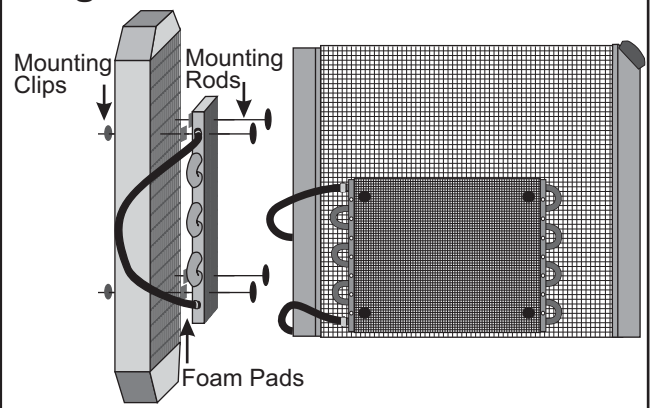

### IMPORTANT

In most cases the Factory Oil Filter will work with the supplied sandwich adapter. In some applications where the frame or exhaust system interferes with the new filter depth we recommend using a shorter filter length.

See chart below for possible filter options.

SLEEVE NUT

**Diagram #3**

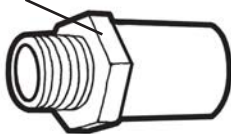

THREAD SIZE	FRAM FILTER HEIGHT	FRAM P/N	WIX FILTER HEIGHT	WIX P/N	FRAM FILTER HEIGHT	FRAM P/N	WIX FILTER HEIGHT	WIX P/N
13/16-16	5.25	PH13	5.17	51060	4.06	PH30	4.33	51069

## **SANDWICH ADAPTER INSTALLATION**

**Note:** This kit is designed to fit GM vehicles Manufactured between 1963-2007, primarily SB & BB V8's.

The Sandwich Adapter fits between the oil filter and the engine block. Before removing the oil filter, check the clearance between the bottom of the filter and the closest vehicle obstruction. If there are none, then proceed with the installation. Otherwise, the Sandwich Adapter is 2-1/4" Thick, so you will need 2-1/2" more clearance than stock. If you determine that the stock filter will not fit, refer to the Filter Chart for alternative filter heights.

1. Remove the factory oil filter from the vehicle.
2. Take the Sandwich Adapter and the two Hose Barb Fittings provided. Using Thread Sealant Tape, screw the Hose Barb Fittings clockwise into the Sandwich Adapter until snug. (See Diagram #2)
3. Using a wrench tighten the two Hose Barb Fittings.
4. Take the O-ring provided, apply a thin film of oil and install into the O-ring groove on the Sandwich Adapter. (See Diagram #2)
5. Making sure the engine block filter landing is clean from oil and dirt, take the Sleeve Nut, Sandwich Adapter, O-ring, and install onto engine sliding the Sleeve Nut thru the Sandwich Adapter. Turn sleeve nut clockwise onto the engines filter nipple. (See Diagram #2)
6. Using a Torque Wrench, torque the Sleeve Nut to 20 ft. Lbs.

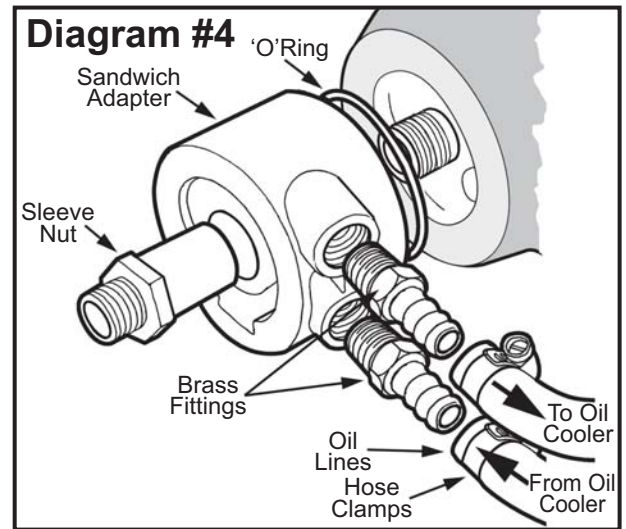

## **ROUTING HOSES**

1. Using the remaining Hose Clamps supplied, route the looped hose carefully along the frame to the Sandwich Adapter already installed on the engine making sure to stay away from moving parts, exhaust systems and any sharp objects.
2. Cut hose at desired length.
3. Connect the outlet port on the Sandwich Adapter to either port on the oil cooler.
4. Connect the inlet port on the Sandwich Adapter to the remaining port on the oil cooler.
5. Tighten Hose Clamps.
6. Using the 6" Zip Ties supplied, secure hoses in place.

**Warning:** When routing hoses, be sure to keep all hoses away from sharp edges, moving parts and hot engine components. Hoses should be routed carefully and should not be bent in less than a 3" radius.

**Important:** A kinked hose will restrict flow and could cause transmission failure.

## **VEHICLE TESTING**

1. Start the engine and quickly check all connections for leaks.
2. Turn-off the engine and check oil level.
3. Add oil as needed.

**Warning:** Installation of accessories should only be undertaken by those with mechanical knowledge and are familiar with working on vehicles. Always use eye protection (goggles, safety glasses or shield). Park the vehicle in a well lit area, on level ground and apply the parking brake. Only work on a cold vehicle that has been sitting overnight, failure to do so will result in severe burns and injury. Before starting the vehicle, make sure no tools or any other items are left under hood that could interfere with or be drawn into moving parts of the engine. Failure to follow instructions can lead to severe damage and personal injury.