

INSTALLATION MANUAL

11665

Level of Difficulty

Difficult

Installation difficulty levels are based on time and effort involved and may vary depending on the installer level of expertise, condition of the vehicle and proper tools and equipment.

Weight Carrying Capacity

Gross trailer weight (GTW)	2,000 lbs.
Tongue weight (TW)	200 lbs.

Parts List

Item	Qty	Description
1	8	Hex bolt, M8 - 1.25 x 30mm
2	8	Conical-toothed washer, M8
3	2	Carriage bolt, 7/16" - 14 x 1.75"
4	2	Spacer, 1/2" x 1/16" x 2-1/4"
5	2	Conical-toothed washer, 7/16"
6	2	Hex nut, 7/16" - 14
7	2	Fishwire, 7/16"

Tools Required

Torque wrench	Flathead screwdriver
Ratchet	Phillips screwdriver
Socket, 11/16"	Tape
Socket, 10mm	Tape measure
Socket, 12mm	Safety glasses
Socket, 13mm	Rotary tool
Socket extension, 6"	Fishwire, 7/16" (includes 2 qty)
Drill	Panel trim removal tool
Drill bit, 1/2"	

* For a tools reference guide visit curtmfg.com/trailer-hitch-installation

⚠ WARNING

Never exceed the vehicle manufacturer's recommended towing capacity.

Product Photo



NOTICE

Visit www.curtmfg.com for a full-color copy of this instruction manual, as well as helpful videos, guides and much more!

Before you begin installation, read all instructions thoroughly.

Proper tools will improve the quality of installation and reduce the time required.

This installation requires:

- Temporary bumper fascia and underbody removal
- Bumper fascia and underbody trim
- Drilling

Periodic inspection of the trailer hitch should be performed to ensure all mounting hardware remains tight and structural components are secure.

To help prevent damage to the product or vehicle, refer to the specified torque specifications when securing hardware during the installation process.

SAFETY INSTRUCTIONS

Safety glasses should be worn at all times while installing this product.

Product Registration and Warranty

CURT stands behind our products with industry-leading warranties. To get copies of the product warranties, register your purchase or provide feedback, visit: warranty.curtgroup.com/surveys

ASSEMBLY

Parts List		
Item	Qty	Description
1	8	Hex bolt, M8 - 1.25 x 30mm
2	8	Conical-toothed washer, M8
3	2	Carriage bolt, 7/16" - 14 x 1.75"
4	2	Spacer, 1/2" x 1/16" x 2-1/4"
5	2	Conical-toothed washer, 7/16"
6	2	Hex nut, 7/16" - 14
7	2	Fishwire, 7/16"

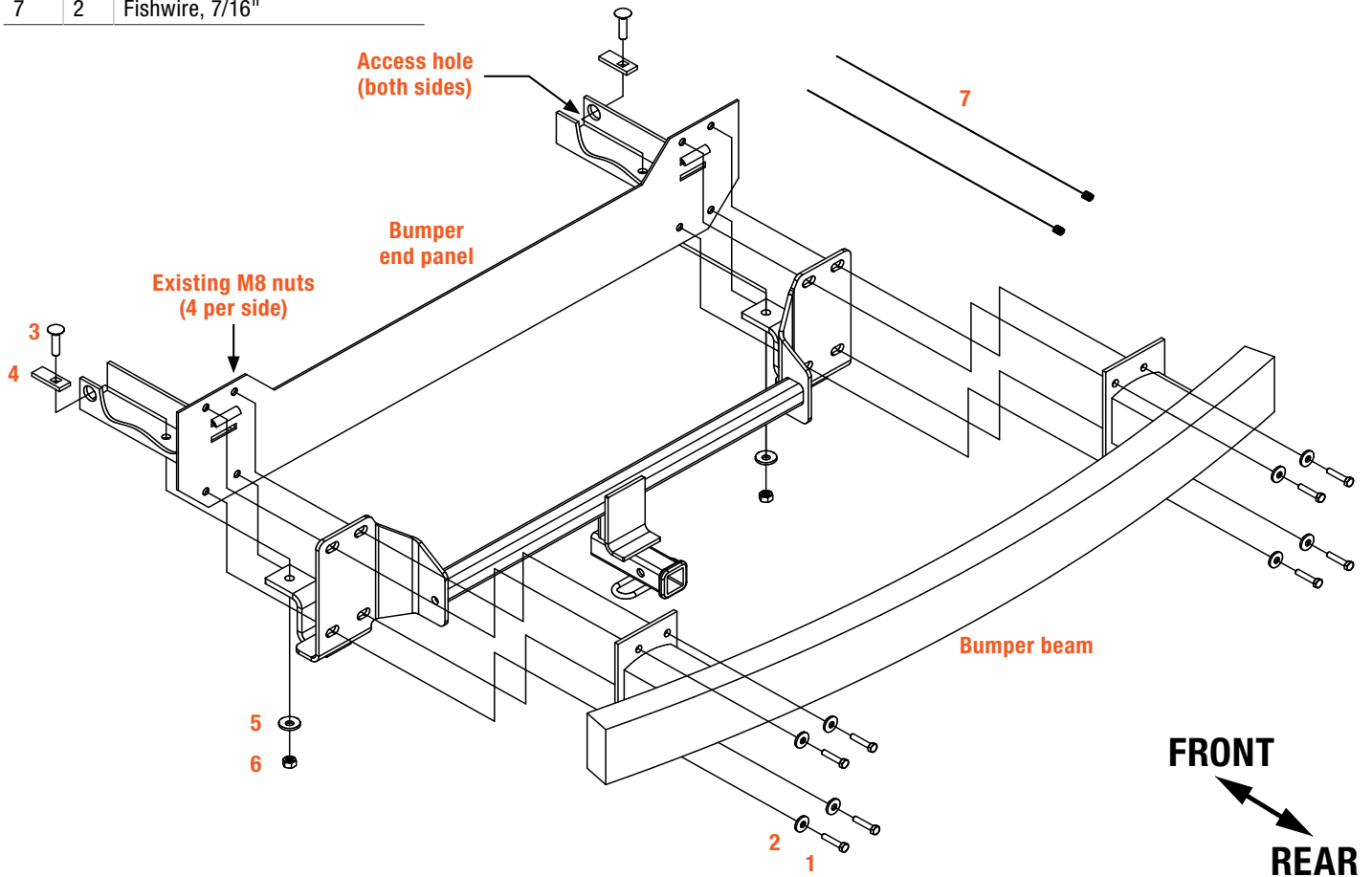

WELDNUT CLEANING
 To remove debris from weldnuts in frame, spray lubricant or compressed air into the hole.
 For heavy debris, use a wire brush. Take care not to damage threads.

CONICAL TOOTHED WASHER ORIENTATION

VEHICLE FRAME
 HITCH SIDE PLATE
 CONICAL TOOTHED WASHER
 HEX BOLT

FISHWIRE TECHNIQUE

Insert coiled end of fishwire tool through hitch mounting hole in vehicle frame rail and out the access hole. Pass coiled end of fishwire through spacer and thread bolt into coil. Kink wire to keep spacer separate from bolt as shown. Pull fishwire, spacer and bolt through frame and out mounting hole. Use fishwire to guide hitch during mounting and prevent loss of bolt or spacer inside frame rail.

ACCESS HOLE
 MOUNTING HOLE

Step 1

Remove the two screws from the wheel well liner on each side of the vehicle using a Phillips screwdriver.

Set screws aside for reinstallation in step 10.

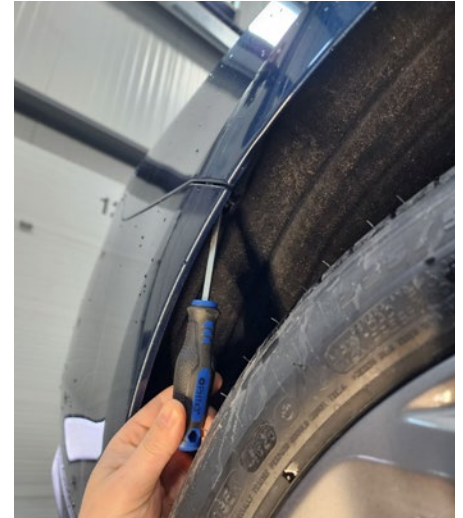

Step 2

Remove the five plastic rivets from the bumper fascia and underbody panel using a flathead screwdriver.

Remove the two screws from the underbody panel using a 10mm socket.

Set the underbody panel, screws, and plastic rivets aside for reinstallation in step 10.

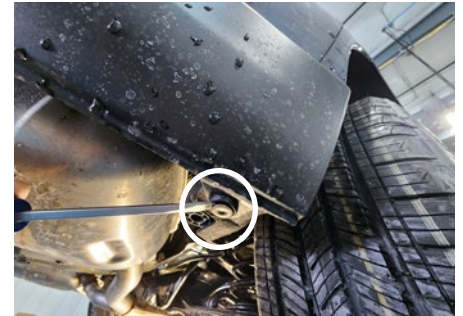

Step 3

Open the trunk and gently remove the taillight trim panel on both sides using a panel trim removal tool.

Remove the single bolt from the fascia on both sides using a 10mm socket.

Set the taillight trim panels and bolts aside for reinstallation in step 10.



Step 4

Gently pull the fascia up from the rear wheel trim panel on each side of the vehicle. Work up to the taillights and continue to remove the panel, working from the bottom of the taillights to the center of the trunk.

Carefully remove the bumper fascia and set aside for reinstallation in step 10.



Step 5

Remove the bumper beam by unscrewing the four M8 factory bolts from the bumper beam plate on each side using a 12mm socket.

Set the bumper beam aside for reinstallation in Step 7.

Return the factory bolts to the vehicle owner.



Step 6

Push the thin metal piece under the bumper plate inward and make it flush with the end panel on each side.



Step 7

Set the bumper beam on top of the trailer hitch.

Raise the bumper and hitch into position, aligning the 8 mounting holes. Secure the bumper and hitch with the provided M8 hex bolts (#1) and conical-toothed washers (#2) using a 13mm socket.

Torque all M8 hardware to 22.9 ft-lbs.



Step 8

On the driver side, locate the hitch bracket hole on the bottom side of the frame. Using the trailer hitch as a guide, drill a 1/2" hole in the center of the hitch bracket hole into the frame.

Feed the carriage bolt (#3) and spacer (#4) through the access hole and hitch bracket hole using fishwire (#7). Remove the fishwire and loosely install the 7/16" conical-toothed washer (#5) and hex nut (#6) to the hitch.

Repeat on the passenger side.

Torque all 7/16" hardware to 59 ft-lbs. using an 11/16" socket.

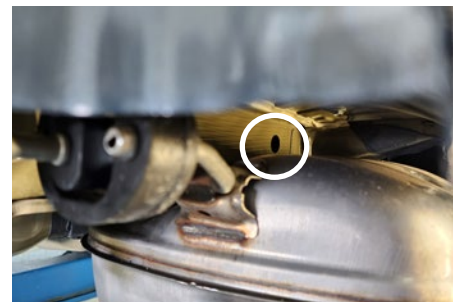
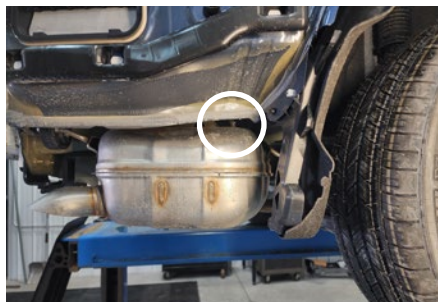

Step 9

Mark and trim the bumper fascia using a tape measure, tape and rotary tool. See the trim diagram for approximate dimensions.



Step 10

Reinstall the bumper fascia, underbody panels, all fasteners, and taillight trim panels set aside in steps 1 through 4.



Final Installed Image



TOWING BASICS & SAFETY INFORMATION

For information on safely towing your trailer, visit curtmfg.com/understanding-towing.