

11643**84-89 TOYOTA VAN**

12/7/2012

GROSS LOAD CAPACITY WHEN USED AS A WEIGHT CARRYING HITCH: 1,500 LBS. TRAILER WEIGHT & 150 LBS. TONGUE WEIGHT.

*****DO NOT EXCEED VEHICLE MANUFACTURER'S RECOMMENDED TOWING CAPACITY.*****

WARNING: ALL NON-TRAILER LOADS APPLIED TO THIS PRODUCT MUST BE SUPPORTED BY 18050 STABILIZING STRAPS.

**** FAILURE TO PROPERLY SUPPORT NON-TRAILER LOADS WILL VOID PRODUCT WARRANTY****

HAVING INSTALLATION QUESTIONS? CALL TECHNICAL SUPPORT AT 1-877-287-8634

Parts List			
ITEM	QTY	PART NUMBER	DESCRIPTION
1	1	1/2-13	HANDLE NUT
2	1	1/2-13 x 1 3/4	HEX BOLT
3	1	1/2"	LOCK WASHER
4	2	7/16-14	HEX FLANGE NUT
5	2	7/16 - 14 x 1 3/4	CARRIAGE BOLT
6	2	CM-SP2	.250 x .88 x 2.25" SQUARE HOLE SPACER
7	2	7_16 FISHWIRE	7/16" FISHWIRE

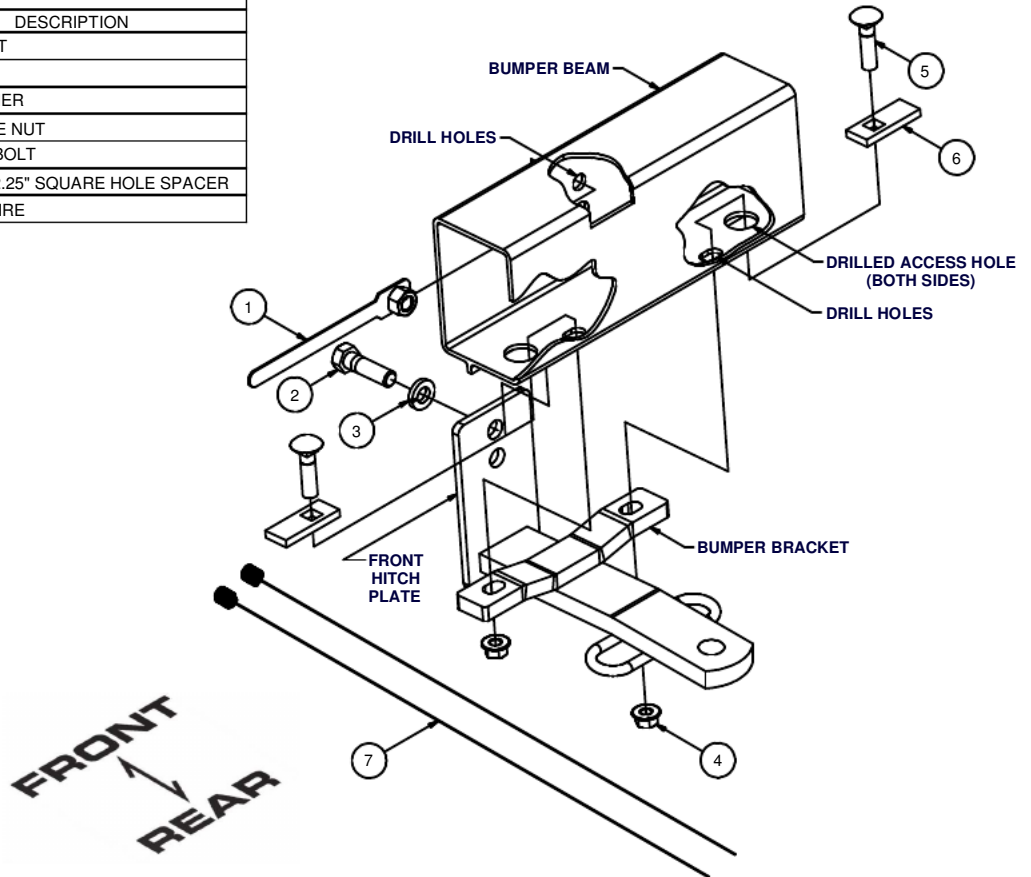

HITCH WEIGHT: 7 LBS.

INSTALL TIME

PROFESSIONAL: 30 MINUTES

NOVICE (DIY): 60 MINUTES

INSTALL NOTES:

- TEMPORARILY REMOVE BUMPER
- DRILLING REQUIRED
- TRIM FASCIA

INSTALLATION STEPS

1. Remove the rear bumper by removing (4) to (6) screws located under rubber covers inside the trunk area or under the vehicle near the bumper ends. Also, check for small screws located at ends of bumper in the fender and remove them.
2. Locate and mark the vehicle's centerline on metal u-channel that retains fascia at the bottom of bumper. An 8" section (4" each side of center) of channel must be cut away. Also cut away an 8" section of rubber fascia so hitch bumper bracket will attach directly to the steel bumper.
3. Place the hitch centered on steel bumper as shown. Using hitch as a template, drill (2) holes in bumper for 7/16" hardware.
4. Fishwire 7/16" carriage bolts and CM-SP2 spacers through drilled holes as shown. Access holes may need to be drilled. Position hitch and fasten using hardware as shown.
5. Drill bumper using best hole in front hitch plate for (1) 1/2" bolt. Secure hitch using 1/2" fasteners with handle nut used inside the bumper. Handle should fit through adjacent hole and be flattened against bumper after final tightening. Use flat washers to shim between plate and bumper if necessary for good fit.
6. Torque all 7/16" fasteners to 70 lb-ft, and all 1/2" fasteners to 110 lb-ft.

PERIODICALLY CHECK THIS RECEIVER HITCH TO ENSURE THAT ALL FASTENERS ARE TIGHT AND THAT ALL STRUCTURAL COMPONENTS ARE SOUND.

Curt Manufacturing Inc., warrants this product to be free of defects in material and/or workmanship at the time of retail purchase by the original purchaser. If the product is found to be defective, Curt Manufacturing Inc., may repair or replace the product, at their option, when the product is returned, prepaid, with proof of purchase. Alteration to, misuse of, or improper installation of this product voids the warranty. Curt Manufacturing Inc.'s liability is limited to repair or replacement of products found to be defective, and specifically excludes liability for incidental or consequential loss or damage.