

Installation Guide for Chevrolet C8 Corvette

PNs 140838, 140838BC, 140838CF, 140839, 140839BC, 140839CF, 140840, 140840BC, 140840CF, 140841, 140841BC, 140841CF



CAUTION!

This system includes heat shielding parts made from thin sheet metal that may pose a risk of inju-

Please compare the parts in the box with the bill of materials provided to ensure that you have all the parts necessary for this installation.

These instructions have been written to help you with the installation of your Borla Performance exhaust system. Please read this document completely before beginning the installation of your system.

To ensure this part number fits your specific model year, please visit our website for the latest model year listings at www.BORLA.com

Thank you for purchasing a Borla Performance Cat-Back™ exhaust system.

These Borla Performance Cat-Back™ exhaust systems (PNs 140838, 140838BC, 140838CF, 140839, 140839BC, 140839CF) are designed for the Chevrolet Corvette, equipped with a 6.2L V8 engine and RWD automatic transmission. Designed for C8 Corvettes equipped with factory performance exhaust option.

These Borla Performance Cat-Back™ exhaust systems (PNs 140840, 140840BC, 140840CF, 140841, 140841BC, 140841CF) are designed for the Chevrolet Corvette, equipped with a 6.2L V8 engine and RWD automatic transmission. Designed for C8 Corvettes **NOT** equipped with factory performance exhaust option.

Borla Performance Industries recommends that an exhaust shop or professional after market parts installer, who has all the necessary equipment, tools and experienced personnel needed for proper installation, should perform the installation of this system. However, if you decide to perform the installation, we recommend someone should help you. Ensure the installer uses all under car safety precautions including eye protection.

Please take time to read and understand the following...

By installing your Borla Performance exhaust system, you indicate that you have read this document and you agree with the terms stated below.

It is the responsibility of the purchaser to follow all installation instruction guidelines and safety procedures supplied with your Borla Performance exhaust system.

Borla Performance Industries assumes no responsibility for damages occurring from misuse, abuse, improper installation, improper operation, lack of responsible care, or all previously stated reasons resulting from incompatibility with other manufacturer's products and/or systems.

Included with your Borla Performance exhaust system is a warranty card. Please read it carefully before you begin any work on your vehicle. If you should have any questions regarding our warranty policy, installation, or any other matter pertaining to your new Borla Performance exhaust system, please give us a call at the number provided on the warranty card.

Minimum Required Tool List:

TOOLS:

1. 3/8" drive ratchet
2. 3/8" drive extension 6"
3. 3/8" drive extension 12" (2)
4. 3/8" socket swivel
5. 15mm socket
6. 13mm socket

7. 10mm socket
8. 7mm socket
9. 13mm wrench
10. 10mm wrench
11. T15 Torx

SHOP SUPPLIES:

1. Spray lubricant

Borla Performance—Bill of Materials

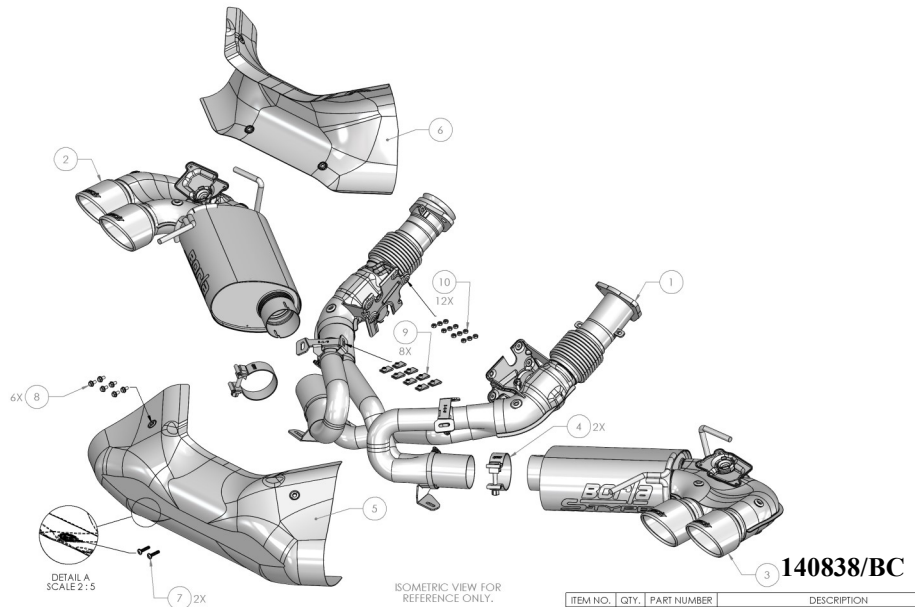

| ITEM NO. | QTY. | PART NUMBER | DESCRIPTION |
|----------|------|-------------|---------------------------------------|
| 1 | 1 | 57363 | FRONT SECTION |
| 2 | 1 | 57364 | L/H MUFFLER ASSEMBLY |
| 3 | 1 | 57365 | R/H MUFFLER ASSEMBLY |
| 4 | 2 | 90114 | 3.00 ACCUSEAL CLAMP |
| 5 | 1 | 470459 | CENTER HEAT SHIELD, RR |
| 6 | 1 | 470456 | CENTER HEAT SHIELD, FR |
| 7 | 2 | 91188 | SCREW: M6 X 1.00 MM THREAD, 30MM LONG |
| 8 | 6 | 9224444 | SCREW: CAP, FLNG HEAD, M6 X12mm X1P |
| 9 | 8 | 93077 | Clip-on Nut: M6 Size, 1mm Pitch |
| 10 | 12 | 93086 | NUT, HEX: M6 X 1mm THREAD |

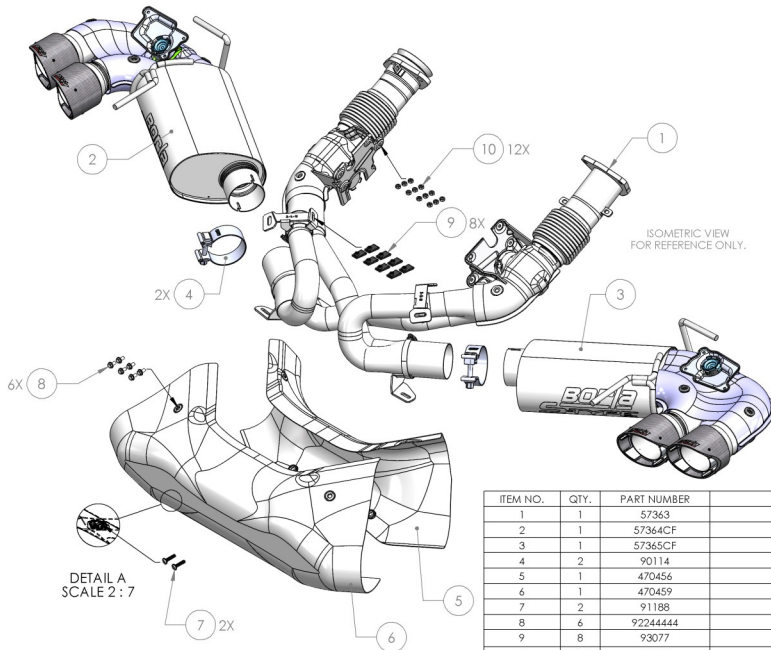

140838CF

| ITEM NO. | QTY. | PART NUMBER | DESCRIPTION |
|----------|------|-------------|---------------------------------------|
| 1 | 1 | 57363 | FRONT SECTION |
| 2 | 1 | 57364CF | L/H MUFFLER ASSEMBLY |
| 3 | 1 | 57365CF | R/H MUFFLER ASSEMBLY |
| 4 | 2 | 90114 | 3.00 ACCUSEAL CLAMP |
| 5 | 1 | 470456 | CENTER HEAT SHIELD, FR |
| 6 | 1 | 470459 | CENTER HEAT SHIELD, RR |
| 7 | 2 | 91188 | SCREW: M6 X 1.00 MM THREAD, 30MM LONG |
| 8 | 6 | 9224444 | SCREW: CAP, FLNG HEAD, M6 X12mm X1P |
| 9 | 8 | 93077 | Clip-on Nut: M6 Size, 1mm Pitch |
| 10 | 12 | 93086 | NUT, HEX: M6 X 1mm THREAD |

Borla Performance - Bill of Materials

140839/BC

| ITEM NO. | PART NUMBER | DESCRIPTION | QTY. |
|----------|-------------|---------------------------------------|------|
| 1 | 57407 | LH FRONT SECTION | 1 |
| 2 | 57408 | RH FRONT SECTION | 1 |
| 3 | 57409 | L/H MUFFLER ASSEMBLY | 1 |
| 4 | 57410 | R/H MUFFLER ASSEMBLY | 1 |
| 5 | 90112 | 2.25 ACCUSEAL CLAMP | 2 |
| 6 | 90118 | S/S ACCUSEAL CLAMP: Ø1.75 | 2 |
| 7 | 470459 | CENTER HEAT SHIELD, RR | 1 |
| 8 | 470456 | CENTER HEAT SHIELD, FR | 1 |
| 9 | 91188 | SCREW: M6 X 1.00 MM THREAD, 30MM LONG | 2 |
| 10 | 92244444 | SCREW: CAP, FLNG HEAD, M6 X 12mm X 1P | 6 |
| 11 | 93077 | Clip-on Nut: M6 Size, 1mm Pitch | 8 |
| 12 | 93086 | NUT, HEX: M6 X 1mm THREAD | 12 |

140839/CF

| ITEM NO. | QTY. | PART NUMBER | DESCRIPTION |
|----------|------|-------------|---------------------------------------|
| 1 | 1 | 57407 | LH FRONT SECTION |
| 2 | 1 | 57408 | RH FRONT SECTION |
| 3 | 1 | 57409CF | L/H MUFFLER ASSEMBLY |
| 4 | 1 | 57410CF | R/H MUFFLER ASSEMBLY |
| 5 | 2 | 90118 | S/S ACCUSEAL CLAMP: Ø1.75 |
| 6 | 2 | 90112 | 2.25 ACCUSEAL CLAMP |
| 7 | 1 | 470459 | CENTER HEAT SHIELD, RR |
| 8 | 1 | 470456 | CENTER HEAT SHIELD, FR |
| 9 | 2 | 91188 | SCREW: M6 X 1.00 MM THREAD, 30MM LONG |
| 10 | 6 | 92244444 | SCREW: CAP, FLNG HEAD, M6 X 12mm X 1P |
| 11 | 8 | 93077 | Clip-on Nut: M6 Size, 1mm Pitch |
| 12 | 12 | 93086 | NUT, HEX: M6 X 1mm THREAD |

140840/BC

| ITEM NO. | QTY. | PART NUMBER | DESCRIPTION |
|----------|------|-------------|--|
| 1 | 1 | 57363 | FRONT SECTION |
| 2 | 1 | 57992 | R/H MUFFLER ASSEMBLY |
| 3 | 1 | 57993 | L/H MUFFLER ASSEMBLY |
| 4 | 2 | 90114 | 3.00 ACCUSEAL CLAMP |
| 5 | 1 | 470456 | CENTER HEAT SHIELD, FR |
| 6 | 1 | 470459 | CENTER HEAT SHIELD, RR, BLACK SURFACE FINISH |
| 7 | 2 | 91188 | SCREW: M6 X 1.00 MM THREAD, 16MM LONG |
| 8 | 6 | 91193 | SCREW: M6 X 1mm Thread, 16mm Lg |
| 9 | 8 | 93077 | Clip-on Nut: M6 Size, 1mm Pitch |
| 10 | 12 | 93086 | NUT, HEX: M6 X 1mm THREAD |

Borla Performance - Bill of Materials

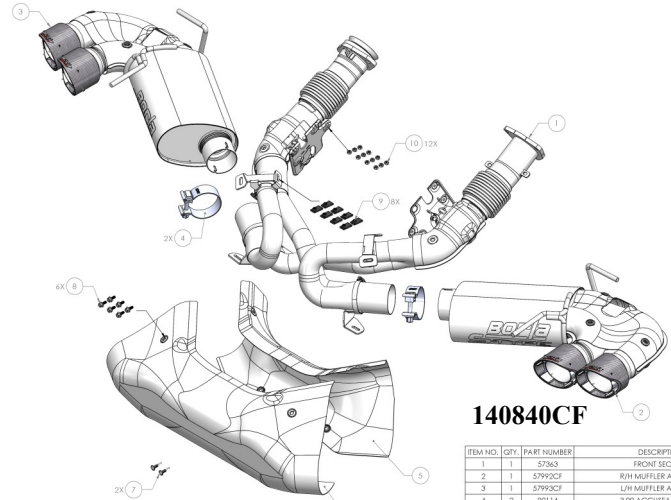

140840CF

| ITEM NO. | QTY. | PART NUMBER | DESCRIPTION |
|----------|------|-------------|--|
| 1 | 1 | 57407 | FRONT SECTION |
| 2 | 1 | 57902CF | R/H MUFFLER ASSEMBLY |
| 3 | 1 | 57993CF | L/H MUFFLER ASSEMBLY |
| 4 | 2 | 90114 | 3.00 ACCUSEAL CLAMP |
| 5 | 1 | 470456 | CENTER HEAT SHIELD, RR |
| 6 | 1 | 470459 | CENTER HEAT SHIELD, RR, BLACK SURFACE FINISH |
| 7 | 2 | 91188 | SCREW: M6 X 1.00 MM THREAD, 16MM LONG |
| 8 | 6 | 91193 | SCREW: M6 X 1mm Thread, 16mm Lg |
| 9 | 8 | 93077 | Clip-on Nut: M6 Size, 1mm Pitch |
| 10 | 12 | 93086 | NUT, HEX: M6 X 1mm THREAD |

| ITEM NO. | QTY. | PART NUMBER | DESCRIPTION |
|----------|------|-------------|--|
| 1 | 1 | 57407 | LH FRONT SECTION |
| 2 | 1 | 57408 | RH FRONT SECTION |
| 3 | 1 | 57994 | R/H MUFFLER ASSEMBLY |
| 4 | 1 | 57995 | L/H MUFFLER ASSEMBLY |
| 5 | 2 | 90118HL | Ø1.75 ACCUSEAL CLAMP |
| 6 | 2 | 90112 | 2.25 ACCUSEAL CLAMP |
| 7 | 1 | 470459 | CENTER HEAT SHIELD, RR, BLACK SURFACE FINISH |
| 8 | 1 | 470456 | CENTER HEAT SHIELD, RR |
| 9 | 2 | 91188 | SCREW: M6 X 1.00 MM THREAD, 16MM LONG |
| 10 | 8 | 93077 | Clip-on Nut: M6 Size, 1mm Pitch |
| 11 | 6 | 91193 | SCREW: M6 X 1mm Thread, 16mm Lg |
| 12 | 12 | 93086 | NUT, HEX: M6 X 1mm THREAD |

140841/BC

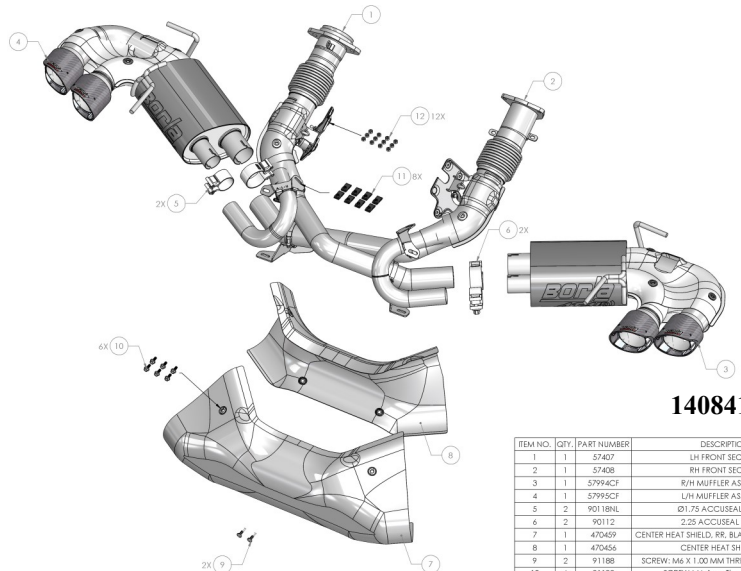
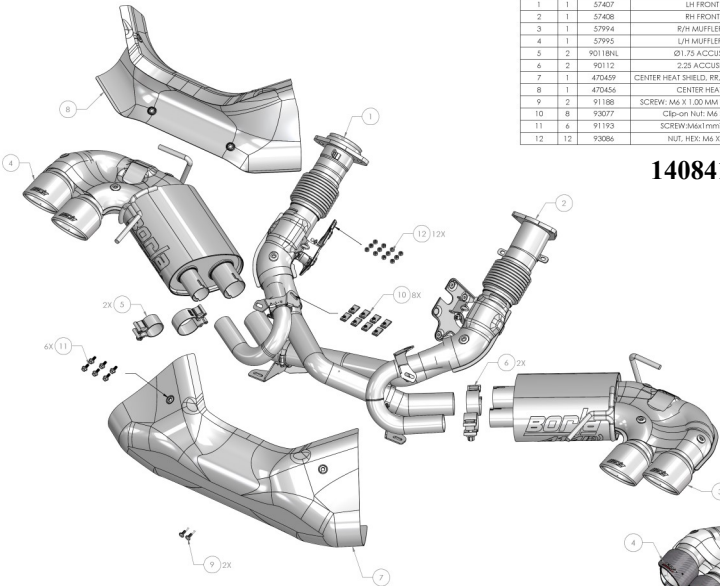

140841CF

| ITEM NO. | QTY. | PART NUMBER | DESCRIPTION |
|----------|------|-------------|--|
| 1 | 1 | 57407 | LH FRONT SECTION |
| 2 | 1 | 57408 | RH FRONT SECTION |
| 3 | 1 | 57992CF | R/H MUFFLER ASSEMBLY |
| 4 | 1 | 57993CF | L/H MUFFLER ASSEMBLY |
| 5 | 2 | 90118HL | Ø1.75 ACCUSEAL CLAMP |
| 6 | 2 | 90112 | 2.25 ACCUSEAL CLAMP |
| 7 | 1 | 470459 | CENTER HEAT SHIELD, RR, BLACK SURFACE FINISH |
| 8 | 1 | 470456 | CENTER HEAT SHIELD, RR |
| 9 | 2 | 91188 | SCREW: M6 X 1.00 MM THREAD, 16MM LONG |
| 10 | 6 | 91193 | SCREW: M6 X 1mm Thread, 16mm Lg |
| 11 | 8 | 93077 | Clip-on Nut: M6 Size, 1mm Pitch |
| 12 | 12 | 93086 | NUT, HEX: M6 X 1mm THREAD |

Caution!!! Never work on a hot exhaust system. Serious injury in the form of burns can result if the vehicle has been in use and the exhaust system is hot, allow vehicle to cool for at least 1 hour. Always wear eye protection when working under any vehicle.

Note: It is our recommendation that you use a hoist or hydraulic lift to facilitate the installation of your new Borla Performance Exhaust System.

Taking all under car safety precautions, lift the vehicle using a hoist or hydraulic lift. Once this has been done, you may begin the removal of your old exhaust system from your vehicle.

Note: Before removing the original exhaust system from your vehicle, please compare the parts you have received with the bill of materials provided on the previous page to assure that you have all the parts necessary for the installation of your new Borla Performance Exhaust System.

Note: With a used vehicle, we suggest a penetrating spray lubricant to be applied liberally to all exhaust fasteners and allowing a significant period of time for the chemical to lubricate the threads before attempting to disassemble.

Original Exhaust System Removal

1. Lubricate all hangers, rubber isolators, bolts and nuts.
2. Remove the rear wheels (fig. 1).
3. Remove the rear splash guards (figs. 2, 3).
4. Remove the rear fender liners (fig. 5). The entire fender liner does not need to come out. You will only need to peel away the rear portion of the liner to access points behind it.



Original Exhaust System Removal Cont'd

5. With the rear fender liner pulled back, loosen the hardware behind it (figs. 5, 6). The hardware will be one 10mm nut and two 7mm fasteners.
6. Loosen the hardware on the underside of the car behind the rear wheel well (fig. 7).
7. Remove the screws on the top of the rear bumper cover (figs. 7, 8).
8. Lift the rear bumper cover away from the back of the car with two people (fig. 9).
9. Using a third person, disconnect the three electrical connectors behind the rear bumper cover (figs. 10, 11).



Original Exhaust System Removal Cont'd

10. Rear bumper cover removed (fig. 12).
11. Remove the screws on the lower cover (fig. 13).
12. Lower cover removed (fig. 14). Be sure to keep the hardware for later reinstallation.
13. Disconnect the electrical connector from the valve actuator to the exhaust valve (fig. 15). There will be 2 NPP (rear) valves. **These actuators will not be present on vehicles without the Performance Exhaust option.**

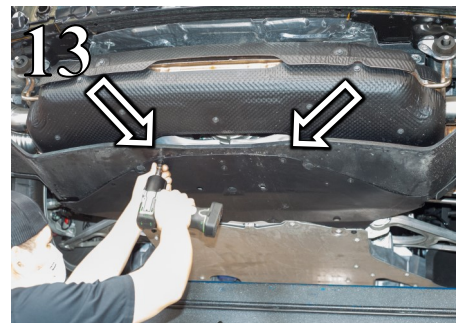
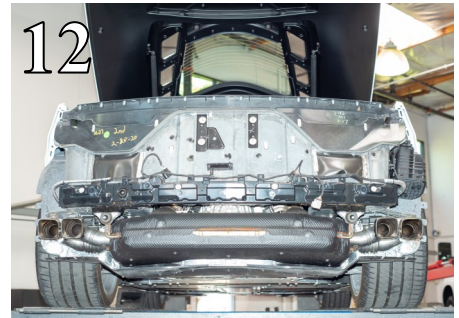
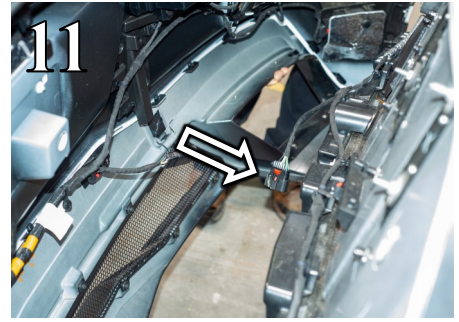

Original Exhaust System Removal Cont'd

14. Remove the rear hanger bolts (fig. 16).
15. Disconnect the electrical connector from the valve actuator to the exhaust valve (fig. 17). There will 2 DFM (front) valves.
16. Remove the bolts on the R/H and L/H front flanges (figs. 18, 19). Bolt loosening method pictured (fig. 20).

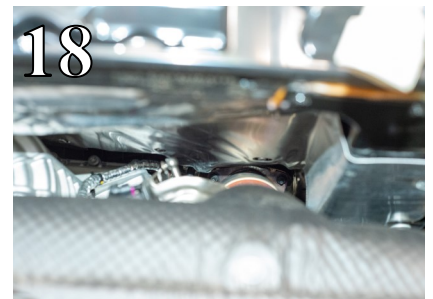
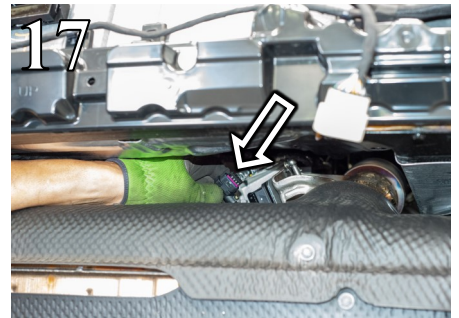
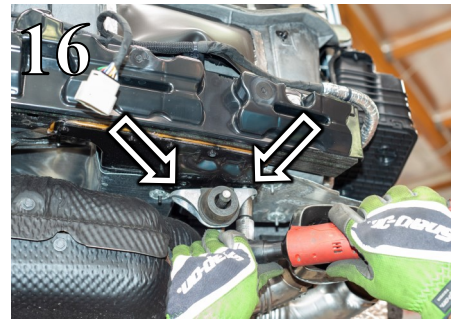

Original Exhaust System Removal Cont'd

17. Remove the hangers from the rubber isolators (figs. 21, 22).
18. Using an additional person, carefully remove the original exhaust system as a single piece (fig. 23).
19. Original exhaust system removed (fig. 24).
 - **Note: Remove both gaskets on the flange ends to be reused on the Borla system. In testing we found no issues with reusing these gaskets, and only recommend replacement if damage is present.**
20. Remove the NPP (rear) exhaust valve actuators and rubber isolators (4) from the original exhaust system (fig. 25). **You will not have NPP exhaust valve actuators present if your vehicle does not have the Performance Exhaust option.**

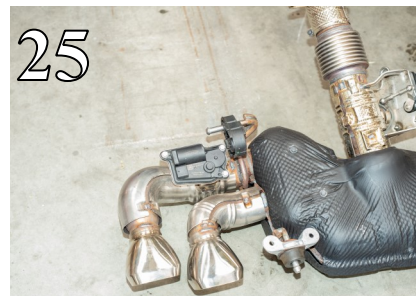
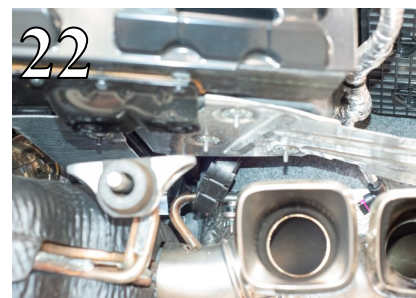

Original Exhaust System Removal Cont'd

21. Locate the two DFM valve actuators near the front flanges (fig. 26).
22. Remove the clip securing the ball socket to the valve actuator ball end (fig. 27). Keep this clip for later reinstallation.
23. Remove the ball socket from the ball end (fig. 28).
24. Remove the screws securing the DFM actuators to the brackets and remove the actuators.

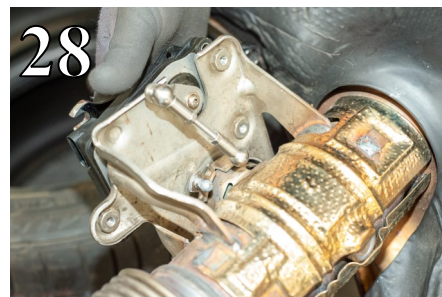
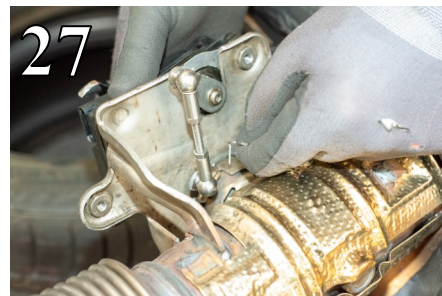
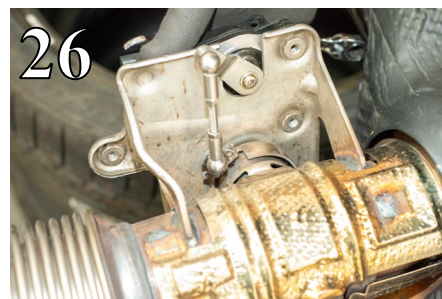

Borla Performance Cat-Back™ Exhaust System Installation

CAUTION!

This system includes heat shielding parts made from thin sheet metal that may pose a risk of injury when handling. Please wear protective equipment and use caution when handling heat shields.

25. Orient the components on shop floor according to the bill of materials drawing provided on pages 2-4.
26. Place the DFM valve actuator on the Borla system.
27. Connect the DFM valve actuator ball socket to the Borla DFM valve assembly (fig. 29). Use the clip to secure the valve actuator arm.
28. Tighten the three screws holding the DFM actuator to the Borla system (fig. 30). Use blue threadlocker to keep the screws secure.
29. Repeat for the other side.
30. Attach the front pipe heat shields from the original exhaust system to the Borla exhaust system (fig. 31).
31. Place the provided U-nuts on all of the heat shield brackets (fig. 32). Ensure that the flat portion of the U-nut faces outward.
32. **ATAK system front pipe installation:** For ATAK systems, install the R/H front pipe assembly (fig. 33). Install the R/H front flange assembly hardware but do not tighten it yet. Repeat for the L/H front pipe assembly (fig. 34). **For S-Type systems, the entire X-pipe assembly goes onto the car as one piece. See next page.**

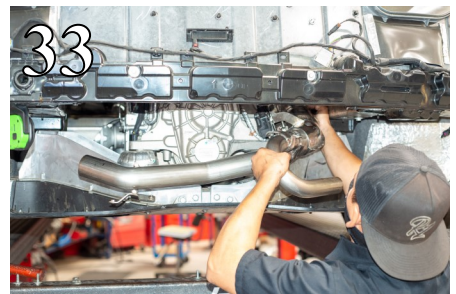
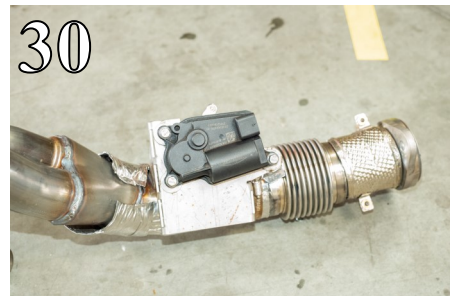
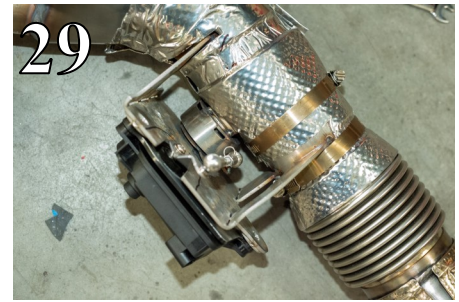

WARNING: Use extreme caution during installation. Torque all fasteners according to manufacturer's torque values and tightening sequence. **DO NOT** use impact tools to tighten fasteners on Borla Performance Exhaust Systems. Use of such tools may result in bent flanges or gasket contact areas leading to exhaust leaks.

Borla Performance Cat-Back™ Exhaust System Installation

CAUTION!

This system includes heat shielding parts made from thin sheet metal that may pose a risk of injury when handling. Please wear protective equipment and use caution when handling heat shields.

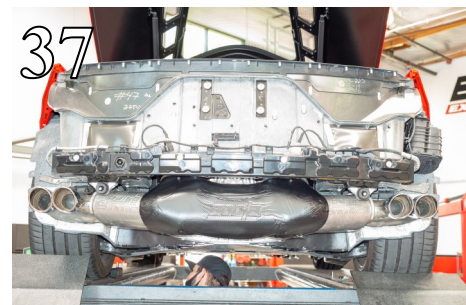

33. ATAK system L/H front pipe installation pictured (fig. 34).
34. Install the rear heat shield over the ATAK front pipe assemblies, at the crossover area (fig. 35). Please note that this method of heat shield installation is not possible with the S-Type systems, and must be done on the shop floor.
35. **S-Type system X-pipe installation:** Install the rear heat shield on the X-pipe assembly on the shop floor (fig. 36). This must be done before installing the X-pipe on the vehicle.
36. S-Type Borla X-pipe assembly installation pictured (fig. 37).
37. Install the nuts on the Borla front flanges (figs. 38, 39). Do not fully tighten the bolts yet.

Borla Performance Cat-Back™ Exhaust System Installation

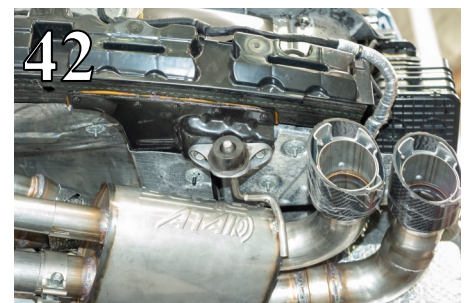
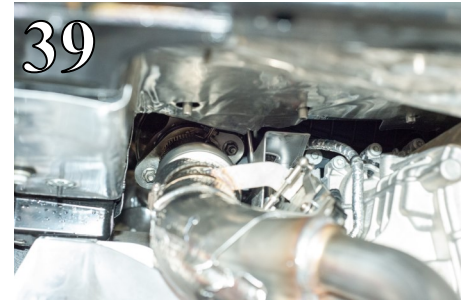

38. Front flange nut installation pictured (fig. 39). Do not fully tighten the nuts yet.
39. Ensure that all required equipment has been transferred to the Borla muffer assemblies before installation (fig. 40). Install valve actuator, rubber isolator, hanger bracket, and slide clamps over inlets. Please note that an ATAK muffer is pictured; S-Type mufflers will have only one inlet. **PNs 140840/BC/CF & 140841/BC/CF will not have a valve that needs an actuator installed.**
40. Connect the R/H muffer assembly to the front pipe/X-pipe assembly (fig. 41). Do not tighten the clamps yet.
41. Tighten the bolts on the R/H hanger bracket (fig. 42).
42. Repeat previous steps for the L/H muffer assembly (fig. 43).
43. Start the vehicle and check for a check engine light (CEL). If a CEL is observed, refer to the valve troubleshooting sheet or call Borla customer service.

Borla Performance Cat-Back™ Exhaust System Installation

CAUTION!

This system includes heat shielding parts made from thin sheet metal that may pose a risk of injury when handling. Please wear protective equipment and use caution when handling heat shields.

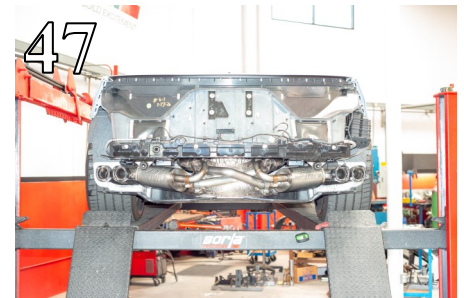
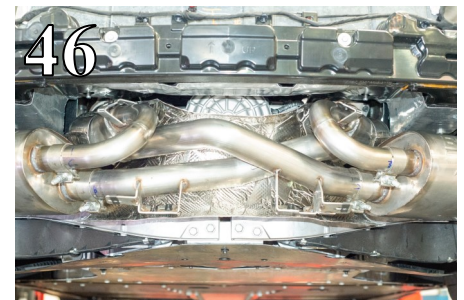
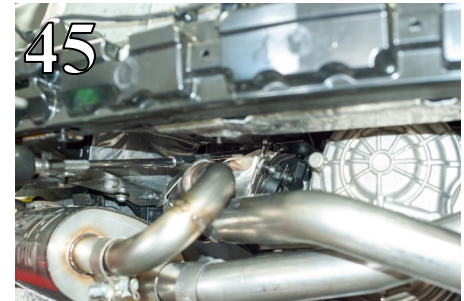

44. Fully tighten the nuts on the front flanges (figs. 44, 45).
45. Tighten the hardware on the clamps on the Borla muffler assemblies (fig. 46). Position the bolt between, not over the notches on the pipes. See image below for reference.
46. Install the front heat shield over the front pipe assembly/X-pipe assembly (fig. 47).
47. Installation progress pictured (fig. 47). Ensure that all hardware is snug and the forward front pipe/X-pipe heat shield is installed.
48. Install the front pipe/X-pipe front heat shield (fig. 48).

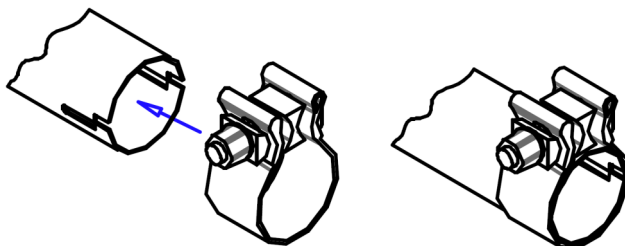

Borla Performance Cat-Back™ Exhaust System Installation

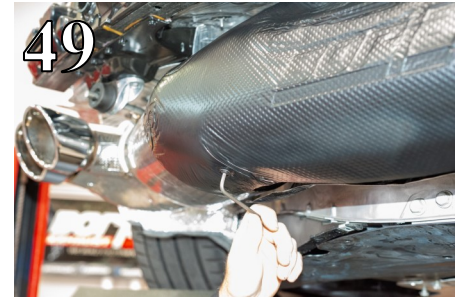

49. Install the included hardware to secure the front pipe assembly/X-pipe assembly front heat shield (fig. 49).
50. Adjust tip height as shown: 1.9"-2.0" from the vehicle's impact absorber to the edge of the Borla exhaust tip (fig. 50).
51. Dry fit the bumper cover and check tip fitment (fig. 51). If necessary, adjust the system fitment by loosening the clamps and sliding the mufflers before fully installing the rear bumper cover.
- 52. If the exhaust system fitment is correct, continue to the next steps.**
53. Starting at the front flanges and moving to the rear of vehicle, tighten the flange hardware/bolts. Orient the position of bolt (on supplied clamps) between (not over) pipe notches and tighten to 35 ft. lbs. torque.
54. Reconnect all electrical connectors between the rear bumper cover and the vehicle (figs. 52, 53).

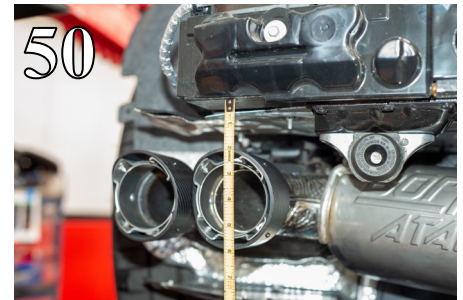

Borla Performance Cat-Back™ Exhaust System Installation

55. Tighten the screws on the top of the rear bumper cover (fig. 54).
56. Tighten the screws on the bottom of the rear bumper cover (fig. 55).
57. Remove the rear wheels (fig. 56).
58. Tighten the screws on the rear wheel well liners (fig. 57).
59. Reinstall the wheel well cover (fig. 58).



Borla Performance Cat-Back™ Exhaust System Installation



60. Tighten the screws on the bottom of the rear bumper cover (fig. 59).
61. Tighten the screws inside the lateral portion of the rear bumper cover (figs. 60, 61).
62. Check your exhaust system for proper clearance under the vehicle and also for tip alignment. Starting at the front flanges and moving to the rear of vehicle, tighten the flange hardware/bolts. Orient the position of bolt (on supplied clamps) between (not over) pipe notches and tighten to 35 ft. lbs. torque.
63. Ensure tips are aligned (fig. 62).
64. Ensure all hardware is tightened.
65. Before starting your vehicle, make sure to check all wires, hoses, brake lines, body parts and tires for safe clearance from the exhaust system.
66. Start the vehicle and check for any leaks. If any leaks are found, determine cause (such as loose or incorrectly positioned clamp) and repair as necessary.

ATTENTION: After installation, the exhaust valves should be re-calibrated according to GM Document ID 5406413. Borla Performance Industries recommends taking your car to the nearest Chevrolet dealer for exhaust valve re-calibration services. Failure to re-calibrate the valves may result in a check engine light and/or negatively impact valve longevity.

NOTE: When you first start your vehicle after the installation of your new Borla Performance Exhaust System, there may be some smoke and fumes coming from the system. This is a protective oil based coating used in the manufacturing of mandrel bent performance exhaust tubing. This is not a problem and will disappear within a very short period of time after the exhaust has reached normal operating temperatures.