

Installation Instructions for '92-'96 Ford F150, F250, F350

Part # 000981

CAUTION: NOT ALL VEHICLES CONFORM TO PUBLISHED SPECIFICATIONS! TEST FIT THIS ASSEMBLY IN YOUR TRUCK BEFORE PAINTING OR ALTERING IN ANY WAY. ONLY ASSEMBLIES IN NEW CONDITION WILL BE ACCEPTED FOR RETURN OR EXCHANGE.

REMOVAL:

1. Engage the ignition switch / steering column lock with the steering wheel & wheels centered.
2. Remove the bolts joining the factory shaft to the steering column and steering shaft. Completely remove the factory universal joint from both the steering column and steering shaft.
3. Remove the original shaft assembly by completely collapsing the shaft then removing from under the hood through the firewall seal. Take care not to damage the original firewall seal, as it will be re-used.

INSTALLATION:

4. Remove universal joint from 1" diameter upper tubular half of the new Borgeson shaft assembly buy 1st loosening both set screws. One set screw is very long and must be removed all of the way. (See Fig. C) Remove universal joint and slide the new shaft thru firewall seal and re-install the universal joint being sure to tighten set screws and then lock nuts. (See Fig. C)
5. With the Borgeson shaft assembly full collapsed. Install upper end of new shaft assembly over column shaft, be sure not to insert shaft too far in to joints. (See Fig. B) Tighten set screws and then lock nuts. **NOTE: Upper column joint must be installed first to insure proper alignment of steering wheel.**
6. Extend shaft so that the lower universal joint reaches the steering box input shaft. Be sure not to insert shaft too far in to joints. (See fig. B) Tighten set screws then lock nuts.
7. After approximately 100 miles, loosen lock nuts and retighten set screws and then lock nuts. We recommend Loctite 222 for ease of removal.

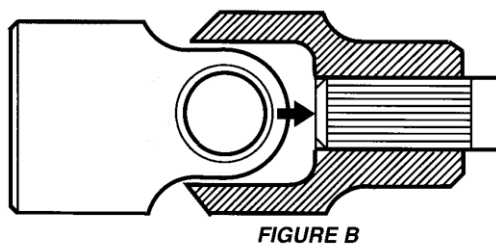

FIGURE B

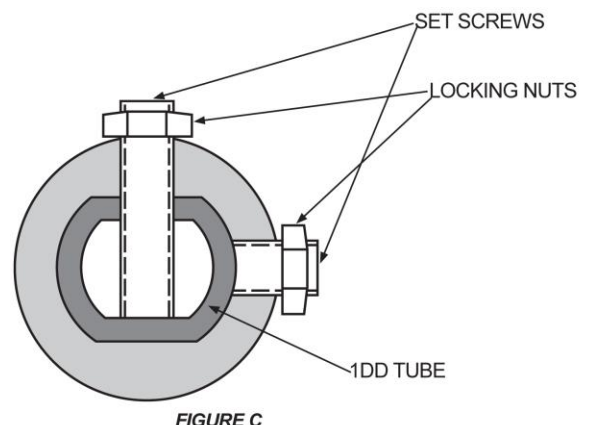

FIGURE C

Borgeson Universal Co., Inc.
9 Krieger Dr. Travelers Rest, SC 29690
www.borgeson.com