



Strong As An Ox™

BX2517 Installation Instructions 2002 Mazda Protege' XL

Serial No.

The front fascia, lower grill, and tie down brackets are removed for baseplate installation. Lower grill will need to be trimmed or left out. Tie down brackets will not be reinstalled. No holes need to be drilled. The BX8869 is available for the vehicle. Attachment Tabs are 20 inches center to center and a height of 11 3/4 inches.



1. Just inside of head lights, on the top side of grill, are two phillips head screws to remove.



2. Remove the four push pins from the top side of fascia.



3. Remove three phillips head push pins inside wheel well, just forward of front tires, both sides.



4. Using the 8MM socket, remove the three metric bolts on lower fascia corner, both sides.



5. Using the 7MM socket, remove the two metric bolts on fascia corner inside front fender, both sides.



6. Remove two metric bolts on the bottom side of fascia with the 10MM socket, both sides.



Strong As An Ox™



7. Remove the four metric bolts from tie down brackets with the 14MM socket, both sides. Tie down brackets will not be reinstalled. Using the hack saw, cut horizontally, the ribbing just forward of tie down bracket location, flush with frame face, and bend forward. Then make two vertical cuts 1/2" up from horizontal cut and bend piece forward. This will allow enough clearance for baseplate.



9. Remove lower grill center from fascia, hold fascia in place on vehicle, then mark and trim lower fascia to allow relief for convenience link, both sides, and reinstall fascia.

11. The dimensional variations between otherwise identical cars can be considerable. While the location and size of the holes in the baseplate were designed to allow for easy installation, it may be necessary to file a hole slightly to allow a bolt to clear.

12. Install the tow bar and safety cables according to the instructions included in their packages.

13. Do **not** substitute other devices if the tow bar pin and clip are lost.

14. **DEALER OR INSTALLER: BE CERTAIN THE USER RECEIVES THE INSTRUCTION SHEET.**



8. Align baseplate with tie down bracket holes, bolt into place using existing metric bolts. Use item 3 on the lower bolts, refer to drawing on last page. **Be sure and use loctite on all bolts before tightening.**



10. Align lower grill to the front of attachment tabs with fascia's opening, trim grill accordingly, and slide into place. Baseplate installation is complete.



Strong As An Ox™

Tools Required

8MM Socket
10MM Socket
Phillips Screw Driver

14MM Socket
Hack Saw

Loctite Blue
Vise Grips

Parts List

Ref. No.	Qty.	Part No.	Description
1	1	61-5777	Weldment, Base Plate, BX2517
2	8		Existing Metric Bolts
3	4	203-0003	3/8 Flat Washer, ZP
4	2	201-0979	#12-14 x 1" Self Drilling Screw, ZP
5	2	201-0192	#10-32 x 1/2 Slot, Rd. Hd. Screw
6	2	203-0054	#10 Lock Washer
7	2	202-0047	#10-32 Hex Nut
8	2	101-5822	Adapter, 4 Way Connector

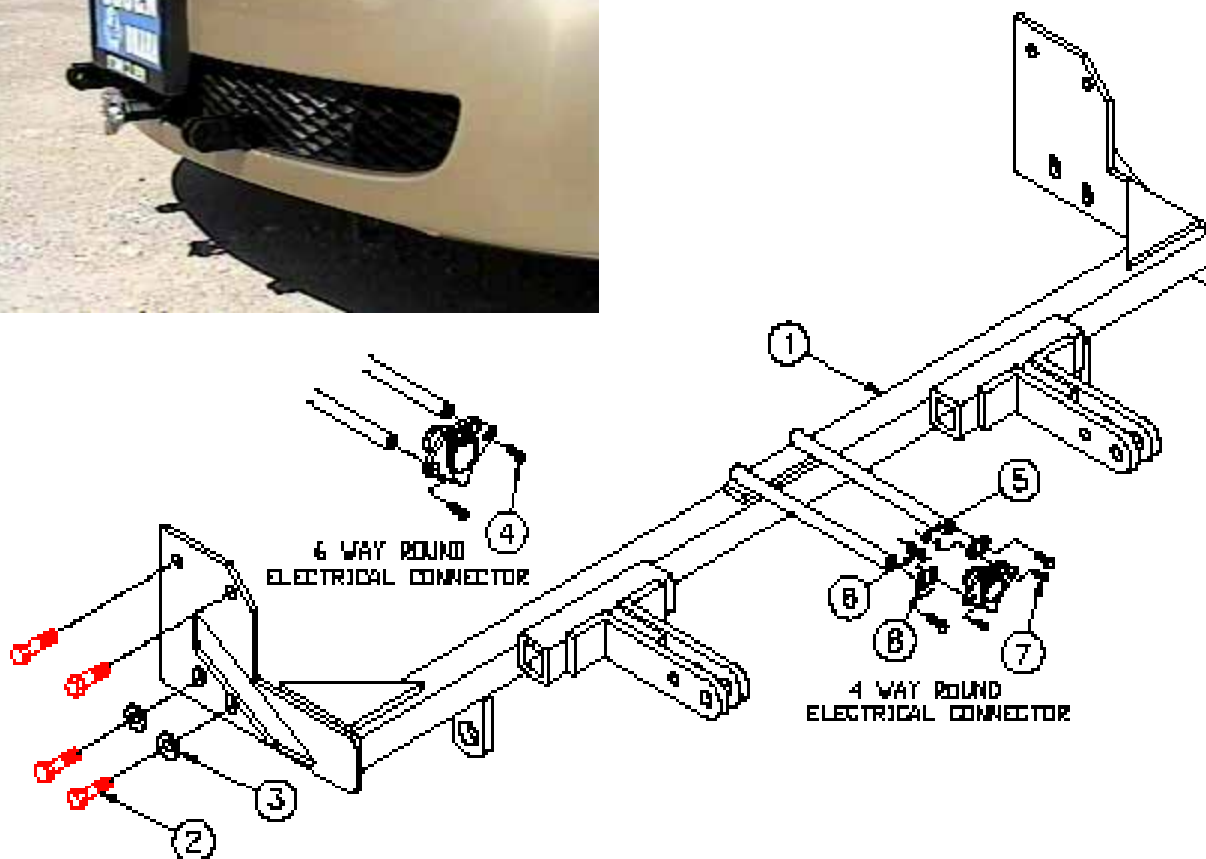

IMPORTANT: Use only genuine factory replacement parts on your Base Plate. Do not substitute homemade or nontypical parts. If a bolt is lost or in need of replacement, for your safety and the preservation of your Base Plate, be sure to use a replacement bolt of the same grade (Usually Grade 5, refer to parts list). Repair parts may be ordered through your nearest **Blue Ox** dealer or distributor.

General Information

1. Ensure that your product(s) are registered online at www.blueox.com. It is crucial to register your product(s) so that you may be alerted of product offerings, updates, upgrades, maintenance and safety bulletins, and/or recalls.
2. **It is the owner's responsibility to inspect all towing equipment for cracked welds, missing or worn parts and loose bolts before each towing trip.** Be sure to use Loctite® Red on all bolts and tighten to the recommended specifications.
3. **It is the owner's responsibility to hook up all towing equipment per manufacturer's instructions/recommendations.**
4. Remove the attachment tabs when not in use (if applicable).

Notice To Baseplate Installer

1. It is YOUR responsibility to watch for:

- Oil cooler and air conditioner lines
- Electrical wires and hoses
- Missing parts or attaching points on the frame

** If the baseplate is improperly installed and is against a wire or hose, it could cause fluid leaks or electrical shorts some time after the actual baseplate installation.

Permanent Baseplate Safety Cable Installation

Permanent baseplate safety cables are strongly recommended when towing a vehicle with a tow bar. The principle function of the permanent baseplate safety cables is to prevent the towed vehicle from breaking loose in the event the connection between the frame of the towed vehicle and the baseplate fails or becomes disconnected. The cables must be connected from the baseplate to the frame rail or cross member of the vehicle's frame. The illustrations below show the possible arrangements recommended by Blue Ox®. Each permanent baseplate safety cable must have an adequate weight rating for the towing system. The weight rating of the two (2) cables together will not qualify.

Do not mount the permanent baseplate safety cables against wires, hoses or brake lines.

These permanent baseplate safety cables should remain installed as long as the baseplate is installed on the vehicle. Permanent baseplate safety cables are to be used in conjunction with, and NOT a replacement for legally required safety cables attaching the towed vehicle to the towing vehicle.

OPTION #1

Permanent Baseplate Safety Cables to Cross Member or Frame of Towed Vehicle.

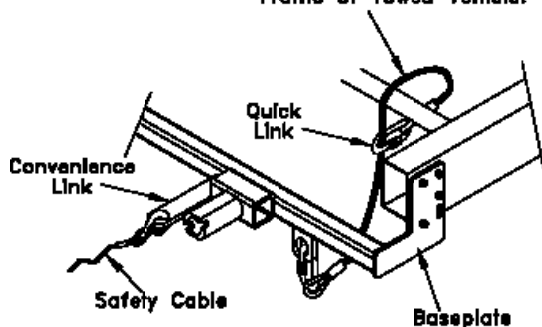

OPTION #2

Permanent Baseplate Safety Cables to Cross Member or Frame of Towed Vehicle.

