



## BX88445

# Blue Ox Camper Leveler Kit Installation Instructions

Serial Number



## Blue Ox Camper Leveler Kit

Set includes leveler and chock

The Blue Ox Camper Leveler Kit allows for easy trailer leveling in increments between 1/2" to 4". Works with trailers up to 35,000 lbs. and a maximum tire diameter of 32". The 13" leveler design length allows for use with dual axel trailers without trimming.



### WARNING

Failure to read and follow these instructions could result in property damage and/or personal injury.



### WARNING

This product can expose you to chemicals including DEHP, which is known to the state of California to cause cancer. For more information go to [www.P65Warning.ca.gov](http://www.P65Warning.ca.gov).

**Please read these Installation Instructions in their entirety prior to installing or operating this equipment.**

BX88445  
 Kit, Blue Ox Camper Leveler  
 Installation Instructions

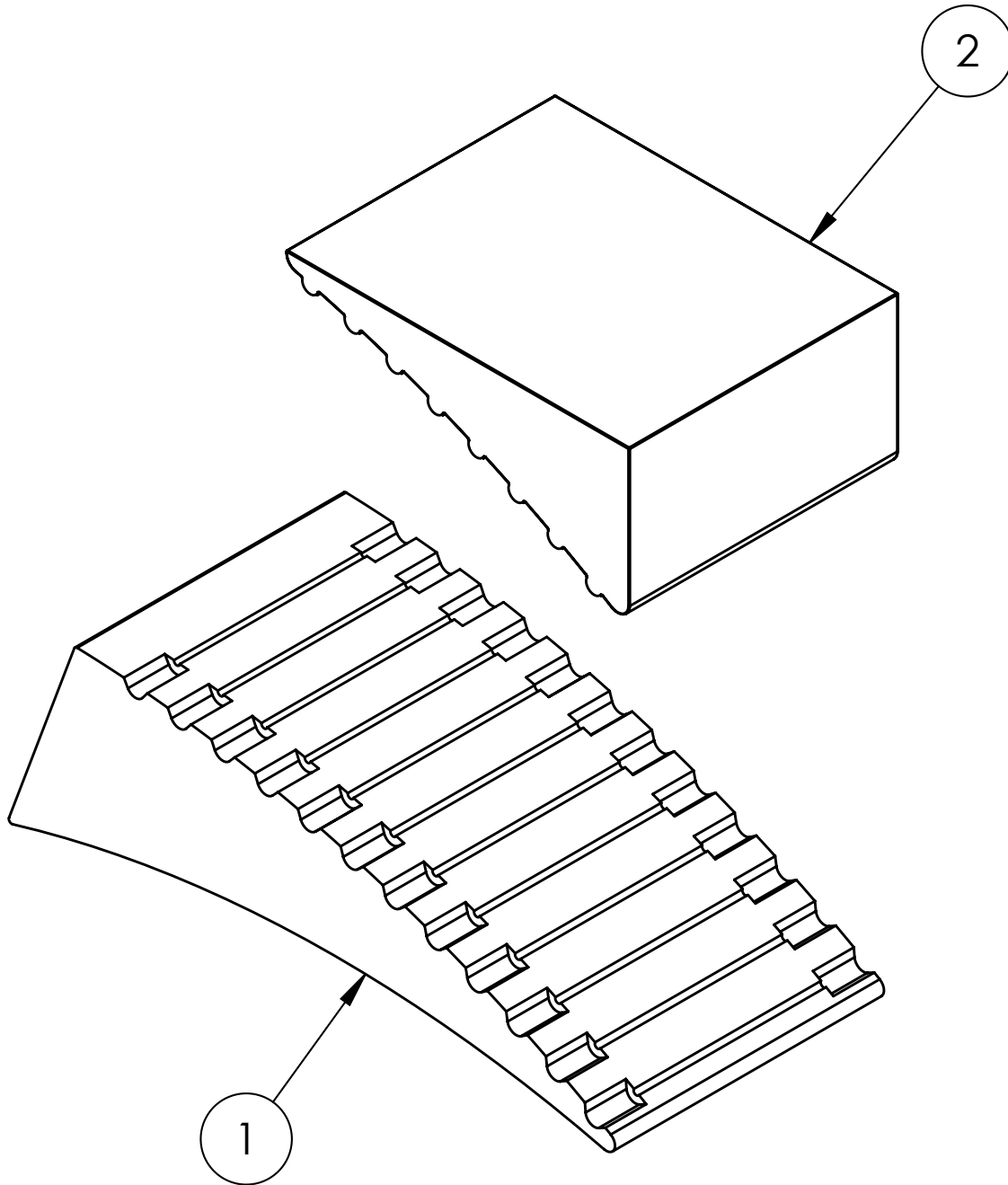

Item No.	Part No.	Description	Qty.
1.....	290-0660 .....	Leveler .....	1
2.....	290-0661 .....	Chock.....	1

**Important:**

Use only genuine factory replacement parts with Leveler System. Do NOT substitute homemade or non-typical parts. Replacement parts may be ordered through Blue Ox®. Failing to follow and/or altering these installation instructions in either installation or required equipment will void the manufacturer's warranty.

BX88445  
Kit, Blue Ox Camper Leveler  
Installation Instructions

**Installation Instructions:**

**NOTE:** YOU ONLY NEED ONE LEVELER PER AXLE ON ONE SIDE OF THE TRAILER. You do not need to level both sides of the trailer, only put them on the low side.

1. Push the thin end of the leveler under the tire either in front or behind depending on if backing up or pulling forward. Ensure the leveler is tightly wedged between the wheel and grip mat.  
**Note:** If using multiple levelers, all levelers should be facing the same direction.
2. Slowly drive or back trailer onto leveler until the camper reaches the desired level.  
**Note:** Recommend using a bubble level to determine that the trailer is level.
3. Slide chock as far as possible under the leveler. Ensure the grooves on the chock lock into place with the grooves on the leveler.

**Tip:** Set-up works best with two people, one driving the vehicle and a second guiding the driver and watching the bubble level.

**Removal Instructions:**

1. Slide chock out from under leveler.
2. Drive off of leveler in the opposite direction it was installed and remove.
4. Store kit in a safe place.



BX88445  
Kit, Blue Ox Camper Leveler  
Installation Instructions

## **CUSTOMER SERVICE COMMITMENT**

Blue Ox® is committed to providing you with exceptional customer care throughout your lifetime with our products. Our team is here to assist you with any questions you may have regarding the performance of your product. Simply call (402) 385-3051 and you can speak with our technical service team.

Additionally, please visit our website to see which rallies our team will be attending. For a nominal fee, our service technician will service your towing system to ensure it's in proper working condition. Also, as a commitment to our customers, should you visit our factory, you can stay at our full service Blue Ox® campground at no charge along with enjoying a factory tour.

Again, thank you for being our customer and for the confidence you have shown in the performance of our products. It is because of customers like you we enjoy the success we have today.



© 2022 Blue Ox  
One Mill Road, Industrial Park  
Pender, Nebraska 68047  
Phone: (402) 385-3051  
Fax: (402) 385-3360  
[www.blueox.com](http://www.blueox.com)

# BLUE OX ORIGINAL PURCHASERS LIMITED LIFETIME WARRANTY

Automatic Equipment Manufacturing Company ("Automatic") warrants to the original (first) retail purchaser that this product, manufactured by Automatic, shall be free from defect in material and workmanship under normal use and service for as long as the original retail purchaser owns the product.

During said period, Automatic will repair or replace any parts that have been returned by the original purchaser, to the factory, transportation prepaid, and in Automatic's sole and absolute opinion found to be defective.

Limitations on Warranty Coverage:

Coverage under this warranty will be valid only if the customer warranty card is returned by the original purchaser within 30 days of purchase.

Coverage under this warranty will be effective only when a copy of the original invoice, showing date and place of purchase, accompanies any claim for warranty. This warranty is NON TRANSFERABLE.

This limited warranty will not cover, in any way or form, any alleged damages caused by incorrect or improper installation, improper use, modification or neglect of product, failure to properly service and maintain, misuse, act of God, accident or failure of the user to follow guidelines contained in the instructional material provided by Automatic.

This warranty does not cover normal wear and tear, paint or rust.

Warrantor assumes no responsibility to the owner for loss of use of product, loss of time, inconvenience or any other damage consequential or otherwise. Including, but not limited to mileage, expense of transporting of product, return shipping expense, mechanics travel time, telephone, road service, towing, and rental during repairs, travel, lodging, loss or damage to personal property or loss of earnings.

**REPAIR OR REPLACEMENT AS SET FORTH IN THIS LIMITED WARRANTY IS THE SOLE EXCLUSIVE REMEDY OF THE PURCHASER. AUTOMATIC SHALL NOT BE LIABLE FOR ANY INCIDENTAL OR CONSEQUENTIAL DAMAGES FOR BREACH OF ANY EXPRESS OR IMPLIED WARRANTY ON THIS PRODUCT. EXCEPT TO THE EXTENT PROHIBITED BY APPLICABLE LAW, ANY IMPLIED WARRANTY OF MERCHANTABILITY OR FITNESS FOR A PARTICULAR PURPOSE ON THIS PRODUCT IS LIMITED IN LENGTH TO THE DURATION OF THIS WARRANTY.**

Please visit <http://blueox.com/warranty/> to register your warranty



**BLUE OX**