



BX3782

2001-03 Toyota RAV4

Installation Instructions

Serial Number

Please read **BOTH** these Installation Instructions and the General Towing Instructions before attempting to install or operate this equipment.

- Blue Ox® towing products and accessories are intended to be installed by Blue Ox® Dealers who are familiar with our products and have the equipment and knowledge to do “fit work”. When necessary, Blue Ox® Dealers can be found at www.blueox.com or by contacting our Customer Care Department at (888) 425-5382.
- Many Blue Ox® Baseplates are designed to use existing holes and hardware to mount the baseplate to the towed vehicle. Even though bolts are there, do not assume they are adequate for baseplate mounting. Always use hardware supplied in the hardware kit or existing hardware specified in the Baseplate Installation Instructions.

Attachment Tab Height: 23”

Attachment Tab Width: 18”

Bolt Torque Specifications		
Torque in Foot-Pounds per Metric Bolts		
Bolt Size	Grade 8.8	Grade 10.9
6MM	6	8
8MM	16	22
10MM	31	40
12MM	54	70
14MM	89	117

Confirm the towability and pre-towing procedures for your vehicle with the owner’s manual or contact the vehicle’s manufacturer for specific towing procedures. You can also contact REMCO for additional information at 1(800)228-2481.

Bolt Torque Specifications		
Torque in Foot-Pounds per Inch Bolts		
Bolt Size	Grade 5	Grade 8
1/4”	10	14
5/16”	19	29
3/8”	33	47
7/16”	54	78
1/2”	78	119
5/8”	154	230



WARNING

Failure to read and follow these instructions could result in separation of the towed vehicle from the tow bar, causing property damage, loss of towed vehicle, personal injury or death.

BX3782
2001-03 Toyota RAV4
Installation Instructions

Parts List

Ref. No.	Qty.	Part #	Description
1	1	61-6577	WLDM'T, BP, BX3782
2	4	61-3799	WELDMENT, NUT PLATE, BX3301
3	5	201-0011	1/2-13 X 1 1/4 HEX BOLT GRD.5, ZP
4	1	201-0060	1/2-13 X 1 HEX BOLT GRD.5, ZP
5	6	203-0012	1/2 LOCK WASHER, ZP
6	1	202-0143	1/2-13 ESSNA JAM NUT, ZP
7	1	202-0094	1/2-13 HEX NYL. INS. LOCK NUT, ZP
8	1	101-6135	BRACKET ELECTRICAL, 90 DEGR.
9	2	201-0192	10-32 X 1/2 SLOT, RD. HD. SCREW
10	2	203-0054	#10 LOCK WASHER
11	2	202-0047	#10-32 HEX NUT
12	2	201-0050	1/4-20 X 3/4 HEX BOLT GRD.5, ZP
13	2	203-0008	1/4 LOCK WASHER, ZP
14	2	202-0069	1/4-20 HEX FLANGE WHIZ LOCK NUT, ZP
15	2	101-5822	ADAPTER, 4 WAY CONNECTOR
16	2	201-0654	#10-16 X 1 SELF DRILLING SCREW
17	2	62-3468	ATT TAB ASSY, REM, SF/SB, 1 HOLE
	2	226-0046	BASEPLATE SAFETY CABLE, 36" CL III (Not Shown)
	2	229-0359	QUICKLINK, 3/8, ZP (Not Shown)
	2	290-0437	RECEIVER, CAP PLUG (BLK) (Not Shown)

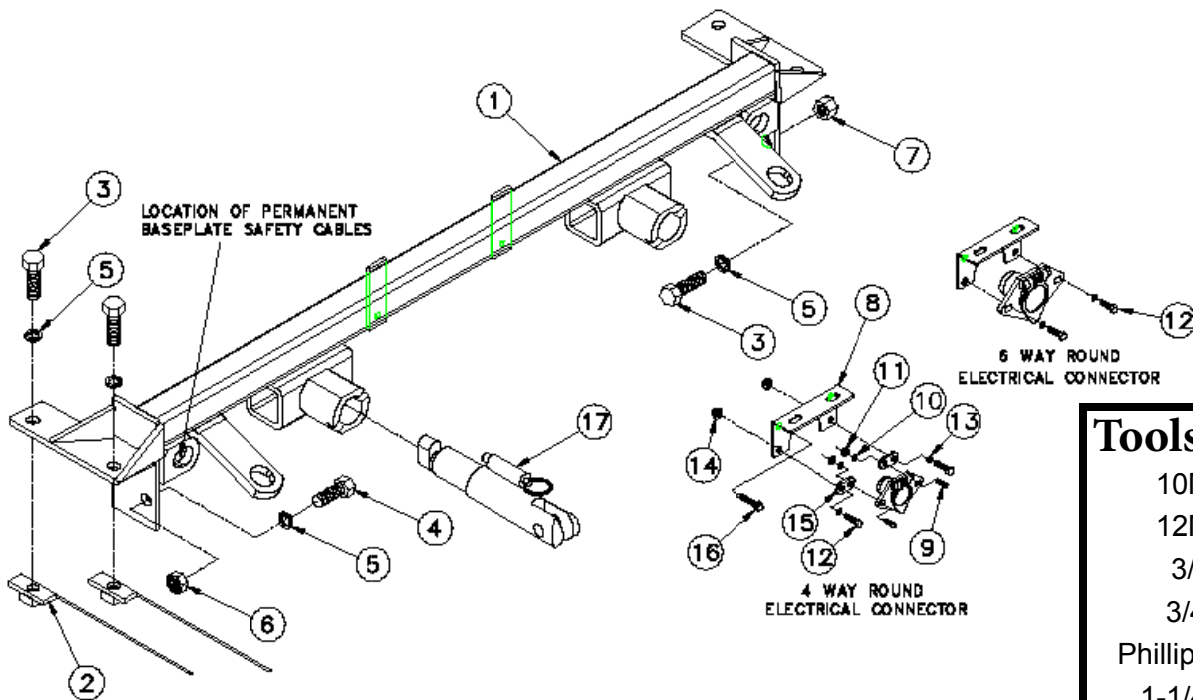

- ### Tools Required
- 10MM Socket
 - 12MM Socket
 - 3/4" Socket
 - 3/4" Wrench
 - Phillips Screwdriver
 - 1-1/4" Hole Saw
 - 17/32" Drill Bit
 - Loctite® RED

Important:

Use only genuine factory replacement parts on your baseplate. Do **NOT** substitute homemade or non-typical parts. If a bolt is lost or in need of replacement, for your safety and the preservation of your baseplate, be sure to use a replacement bolt of the same grade (In most cases it will be Grade 5, please reference the parts list above). Replacement parts may be ordered through your nearest Blue Ox® Dealer or Distributor.

BX3782
2001-03 Toyota RAV4
Installation Instructions

Attachment Tabs:

Motorhome mount tow bars are recommended for use with this baseplate. Due to the design of the removable tabs, the RangeFinderII, Adventurer and Ambassador tow bars can not be used. The Acclaim tow bar may be used, but will not fold and store on the front of the vehicle. Adapters, except the BX8833 and BX88151, can not be used with this baseplate.

Installation Notes: The grille, bumper, fascia and horns must be removed and replaced during installation. Some trimming is required of the bumper. Some drilling is required. The headlights must be removed and replaced during installation.

The dimensional variations between otherwise identical vehicles can be considerable. While the baseplate was designed for easy installation, it may be necessary to tailor the baseplate slightly to compensate for auto manufacturer's tolerances. These minor adjustments may include filing a hole slightly, bending electrical rods, and/or bending end plates.

The BX8869 Bulb and Socket Wiring Kit is recommended for this vehicle.

Installation Instructions:



1. Open hood and remove seven phillips head screws from the top of grill. Set screws aside to be reinstalled later.



2. Pull the top of grille face forward depress two insert clips on backside of grill and remove. Set clips aside to be reinstalled later.

BX3782
2001-03 Toyota RAV4
Installation Instructions



3. Extract four Phillips head push pins from top of grille trim. Notice clips on grille trim just under head light assembly. Set push pins aside to be reinstalled later.



4. Carefully pry apart grille trim with flat screw driver making sure not to scratch paint and the clips are not damaged.



5. Use 10MM socket to remove hex bolt and then a Phillips screw from inside of front wheel shroud, both sides. Set bolts and screws aside to be reinstalled later.



6. Underneath bumper fascia, remove seven hex bolts with 10MM socket, unplug blinker and fog lights, and pull bumper fascia forward. Set bolts and bumper aside to be reinstalled later.

BX3782
2001-03 Toyota RAV4
Installation Instructions



7. There are four hex bolts on the metal bumper that require a 12MM socket to remove.



8. Drill the existing hole out to 1/2". Do this on both sides.



9. On the back side of the bumper, pull the four clips out. Set the horn's electrical cables aside to clear the area for baseplate installation and to be reinstalled later.



10. Using a 12MM socket, remove both horns. They will be remounted elsewhere.

BX3782
2001-03 Toyota RAV4
Installation Instructions

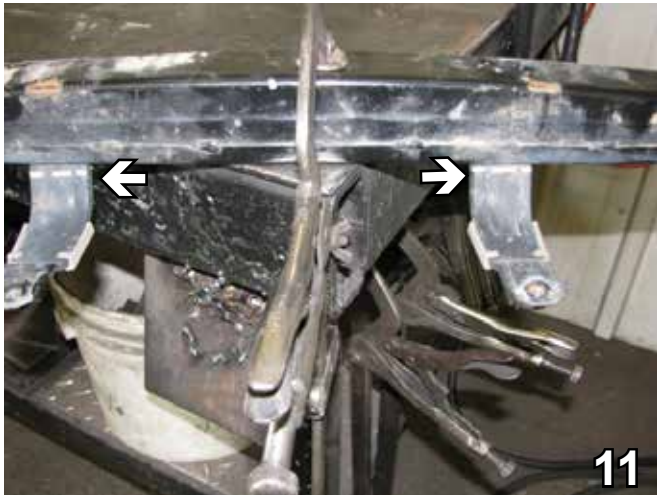

11. Using the hack saw, cut the brackets off at the marked area level with the top of the bumper.

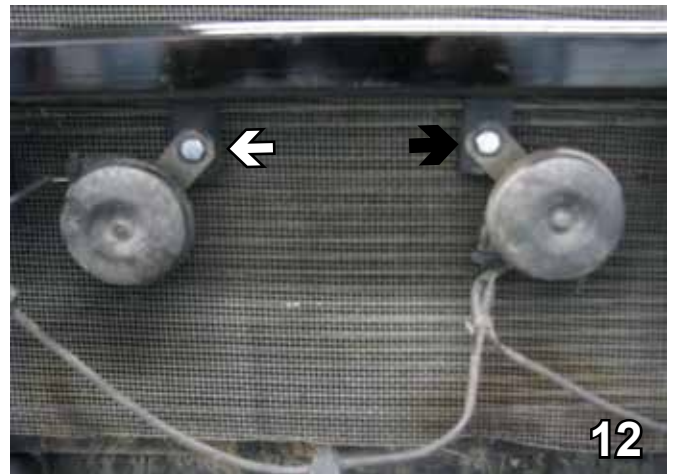

12. Reattach horns to the radiator cover as shown.

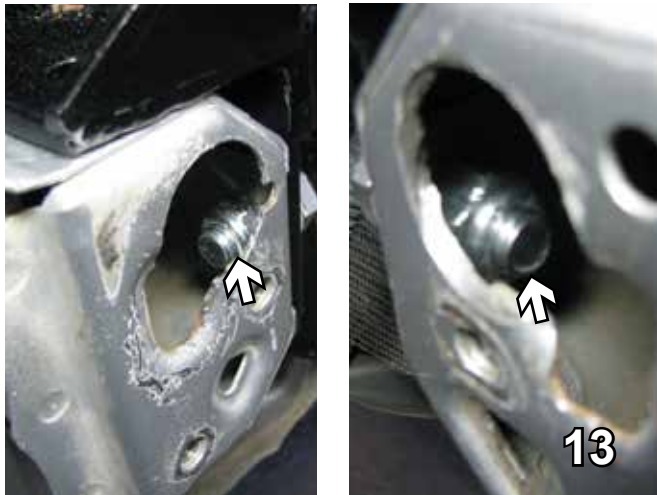

13. Set the baseplate up in place. On the driver's side, start a 1 1/4" bolt with a 1/2" lock washer attached to a 1/2" nylon insert lock nut. On the passenger side, use a 1" bolt with 1/2" lock washer attached to a 1/2" jam nut.



14. Use a 10MM socket to remove the three bolts from the headlight assembly, two on the top and one on the bottom. Pull out the assembly in order to drill the holes but do not disconnect the wiring.

BX3782
2001-03 Toyota RAV4
Installation Instructions



15. On the passenger side, using the baseplate as a template, drill the two holes with the 17/32" drill bit.



16. On the driver's side, use a 10MM socket to remove the two bolts from the brace.



17. Continuing on the driver's side, drill the two holes with the 17/32" drill bit using the baseplate as a template.



18. Install 1 1/4" bolts with 1/2" lock washers into the drilled holes, tighten with 1/2" nut plates inserted into the hole on the side (gray arrow). Be sure to use Loctite Red on all bolts. Do this on both sides, driver's side shown.

BE SURE TO USE LOCTITE® RED ON ALL BOLTS BEFORE TIGHTENING. TIGHTEN ALL BOLTS ACCORDING TO THE TORQUE CHART ON THE FRONT PAGE OF THESE INSTRUCTIONS OR ON PAGE 3 OF THE BASEPLATE TOWING GENERAL INSTRUCTIONS.

BX3782
2001-03 Toyota RAV4
Installation Instructions



19. Install 1 1/4" bolts with 1/2" lock washers into the drilled holes, tighten with 1/2" nut plates inserted into the hole on the side (gray arrow). Be sure to use Loctite Red on all bolts. Do this on both sides, passenger side shown.

BE SURE TO USE LOCTITE® RED ON ALL BOLTS BEFORE TIGHTENING. TIGHTEN ALL BOLTS ACCORDING TO THE TORQUE CHART ON THE FRONT PAGE OF THESE INSTRUCTIONS OR ON PAGE 3 OF THE BASEPLATE TOWING GENERAL INSTRUCTIONS.



20. Attach the permanent baseplate safety cables to the provided convenience link on the baseplate (see grey arrow). The photo above shows the recommended installation of the permanent baseplate safety cables to frame of the vehicle (see white arrow). If the vehicle has additional options, not shown above, which interfere with mounting the permanent baseplate safety cables, secure the cable to a solid piece of the vehicle's frame as described in the instructions included with the permanent baseplate safety cables.

22. Reinstall the headlight, bumper, fascia, grille, screws, clips, pushpins and bolts.

Install the tow bar and safety cables according to the instructions provided in their packages. When demonstrating this to the customer, be sure to include all the contents and packages.

Do **NOT** substitute other devices if the tow bar pins and clips are misplaced.

Be sure that ALL electrical connections are plugged in properly and functioning BEFORE installing the fascia.



21. Cut 1" off the top of the bracket where it starts to bend. Put two holes in the top for the 1" self drilling screws. Attach the plug.

BX3782
2001-03 Toyota RAV4
Installation Instructions

CUSTOMER SERVICE COMMITMENT

Blue Ox is committed to providing you with exceptional customer care throughout your lifetime with our products. Our team is here to assist you with any questions you may have regarding the performance of your product. Simply call 1-800-228-9289 and you can speak with our customer care team.

Additionally, please visit our website to see which rallies our Destination America team will be attending. For a nominal fee, our service technician will service your towing system to ensure it's in proper working condition. Also as a commitment to our customers, should you visit our factory you can stay at our full service Blue Ox campground at no charge along with enjoying a factory tour.

Again thank you for being our customer and for the confidence you have shown in the performance of our products. It is because of customers like you we enjoy the success we have today.



Shown without removable tabs installed.

DEALER or INSTALLER:

Be certain the user receives the instruction sheets for their products.



Shown with removable tabs installed.



© 2006 Blue Ox
One Mill Road, Industrial Park
Pender, Nebraska 68047
Phone: (402) 385-3051 • Fax: (402) 385-3360
www.blueox.com

General Information

1. Ensure that your product(s) are registered online at www.blueox.com. It is crucial to register your product(s) so that you may be alerted of product offerings, updates, upgrades, maintenance and safety bulletins, and/or recalls.
2. **It is the owner's responsibility to inspect all towing equipment for cracked welds, missing or worn parts and loose bolts before each towing trip.** Be sure to use Loctite® Red on all bolts and tighten to the recommended specifications.
3. **It is the owner's responsibility to hook up all towing equipment per manufacturer's instructions/recommendations.**
4. Remove the attachment tabs when not in use (if applicable).

Notice To Baseplate Installer

1. It is YOUR responsibility to watch for:

- Oil cooler and air conditioner lines
- Electrical wires and hoses
- Missing parts or attaching points on the frame

** If the baseplate is improperly installed and is against a wire or hose, it could cause fluid leaks or electrical shorts some time after the actual baseplate installation.

Permanent Baseplate Safety Cable Installation

Permanent baseplate safety cables are strongly recommended when towing a vehicle with a tow bar. The principle function of the permanent baseplate safety cables is to prevent the towed vehicle from breaking loose in the event the connection between the frame of the towed vehicle and the baseplate fails or becomes disconnected. The cables must be connected from the baseplate to the frame rail or cross member of the vehicle's frame. The illustrations below show the possible arrangements recommended by Blue Ox®. Each permanent baseplate safety cable must have an adequate weight rating for the towing system. The weight rating of the two (2) cables together will not qualify.

Do not mount the permanent baseplate safety cables against wires, hoses or brake lines.

These permanent baseplate safety cables should remain installed as long as the baseplate is installed on the vehicle. Permanent baseplate safety cables are to be used in conjunction with, and NOT a replacement for legally required safety cables attaching the towed vehicle to the towing vehicle.

OPTION #1

Permanent Baseplate Safety Cables to Cross Member or Frame of Towed Vehicle.

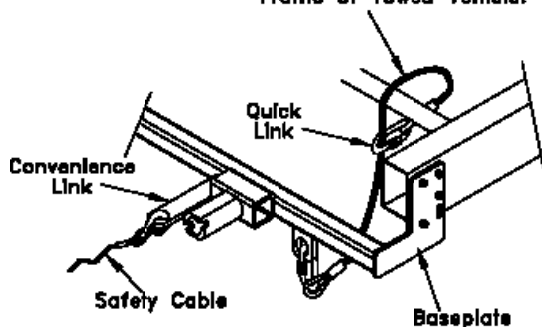

OPTION #2

Permanent Baseplate Safety Cables to Cross Member or Frame of Towed Vehicle.

