



BX3763

2005-2015 Toyota Tacoma (Includes Prerunner)

Installation Instructions

Attachment Tab Height: 11.5"

Attachment Tab Width: 30.5"

Serial Number

Please read BOTH these Installation Instructions and the General Instructions prior to installing or operating this equipment.

- Blue Ox® towing products and accessories are intended to be installed by Blue Ox® Dealers who are familiar with our products and have the equipment and knowledge necessary to do "fit work". When necessary Blue Ox® Dealers can be found at www.blueox.com or by contacting our Customer Care Department at (402) 385-3051.
- Many Blue Ox® baseplates are designed to use existing holes and hardware to mount the baseplate to the towed vehicle. Even though bolts are there, do not assume they are adequate for baseplate mounting. Always use hardware supplied in the hardware kit and existing hardware where specified in the installation instructions.



If the front of your vehicle looks different than this, please call us at (402)385-3051.

Reference your vehicle owner's manual for manufacturer's towing specifications.

Bolt Torque Specifications
Torque in Foot-Pounds for Inch Bolts

Bolt Size	Grade 5	Grade 8
1/4"	10	14
5/16"	19	29
3/8"	33	47
7/16"	54	78
1/2"	78	119
5/8"	154	230
3/4"	257	380

Bolt Torque Specifications
Torque in Foot-Pounds for Metric Bolts

Bolt Size	Grade 8.8	Grade 10.9
6MM	6	8
8MM	16	22
10MM	31	40
12MM	54	70
14MM	89	117
16MM	161	230
18MM	222	318

! WARNING

Failure to read and follow these instructions could result in separation of the towed vehicle from the tow bar, causing property damage, loss of towed vehicle, personal injury or death.



BX3763

2005-2015 Toyota Tacoma (Includes Prerunner)

Installation Instructions

Removable Tabs: Motorhome mount tow bars are recommended for use with this baseplate. Due to the design of the removable tabs the RangeFinderII and Ambassador tow bars can not be used. Adapters, except the BX8833 and BX88151, can not be used with this baseplate.

Instruction Notes: The fascia is removed and reinstalled for the baseplate installation. Some drilling and trimming is required.

The dimensional variations between otherwise identical vehicles can be considerable. While the baseplate was designed for easy installation, it may be necessary to tailor the baseplate slightly to compensate for vehicle manufacturer's tolerances. These minor adjustments may include filing a hole slightly, bending electrical rods or bending end plates.

The BX8869 Tail Light Wiring Kit is recommended for this vehicle. Location for the BX8869 is on the driver's side tail light assembly.

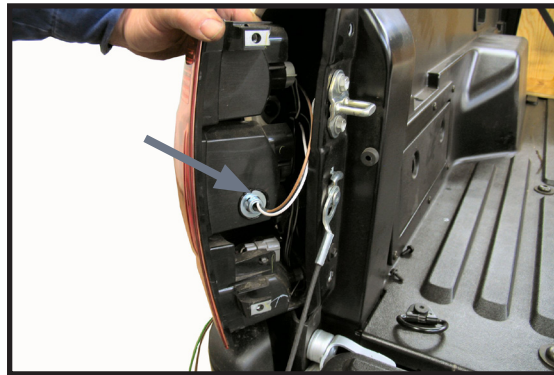

NOTICE

- Handling of some cosmetic parts when installing this product may require the use of protective covers, rags, specialty tools, etc. to prevent damage.
- When using power drills be aware of the dangers of torque and drill bit length.
- Be sure that ALL electrical connections are plugged in properly and functioning before installing the fascia.
- Do not use the towed vehicle for storing luggage, equipment, etc. This may cause you to exceed the towing capacity of the tow bar, baseplate, and its accessories.
- Be sure to use Loctite® Red on all bolts before tightening. Tighten all bolts according to the torque chart provided.



BX3763

2005-2015 Toyota Tacoma

(Includes Prerunner)

Installation Instructions

TOOLS REQUIRED

10MM Socket	12MM Socket	17MM Socket
9/16" Socket	3/4" Socket	3/4" Wrench
5/16" Nut Driver	Large Vise Grip	Reciprocating
Saw	Torque Wrench	Tape Measure
Drill	Loctite® Red	13/32" Drill Bit

PARTS LIST

Item No.	Qty.	Part No.	Description
1	4	61-4604	1/2"-13 Nut Plate Weldment with 10" Wire
2	4	61-5208	3/8"-16 Nut Plate Weldment with 14" Wire
3	1	61-6134	BX3763 Baseplate
4	2	62-3468	Attachment Tab Assembly with Hole
5	1	101-6135	90° Electrical Bracket
6	1	101-6804	BX3763 Passenger Side Convenience Link
7	1	101-6928	BX3763 Driver Side Convenience Link
8	2	107-2759	Spacer Tube
9	4	201-0011	1/2"-13 x 1-1/4" Hex Head Bolt, Grade 5, ZP
10	3	201-0050	1/4"-20 x 3/4" Hex Head Bolt, Grade 5, ZP
11	2	201-0192	#10-32 1/2" Round Slotted Head Screw
12	4	201-0411	12MM-1.25 x 40MM Hex Head Bolt, Grade 5, ZP
13	4	201-0444	3/8"-16 x 2" Hex Head Bolt, Grade 5, ZP
14	2	201-0581	1/2"-13 x 4" Hex Head Bolt, Grade 5, ZP
15	2	201-0979	#12-14 x 1" Self Drilling Screw, ZP
16	2	202-0005	1/2"-13 Hex Nut, ZP
17	2	202-0047	#10-32 Hex Nut
18	3	202-0102	1/4"-20 Hex Nut with Nylon Insert, ZP
19	2	203-0005	1/2" Flat Washer, ZP
20	4	203-0010	3/8" Lock Washer, ZP
21	6	203-0012	1/2" Lock Washer, ZP
22	2	203-0054	#10 Lock Washer
23	4	203-0105	12MM Lock Washer, ZP
24	2	226-0049 (not shown)	36" Class IV Baseplate Safety Cable
25	2	229-0512 (not shown)	1/2" Quicklink, ZP
26	2	290-0437 (not shown)	Black Receiver Cap Plug



BX3763

2005-2015 Toyota Tacoma

(Includes Prerunner)

Installation Instructions

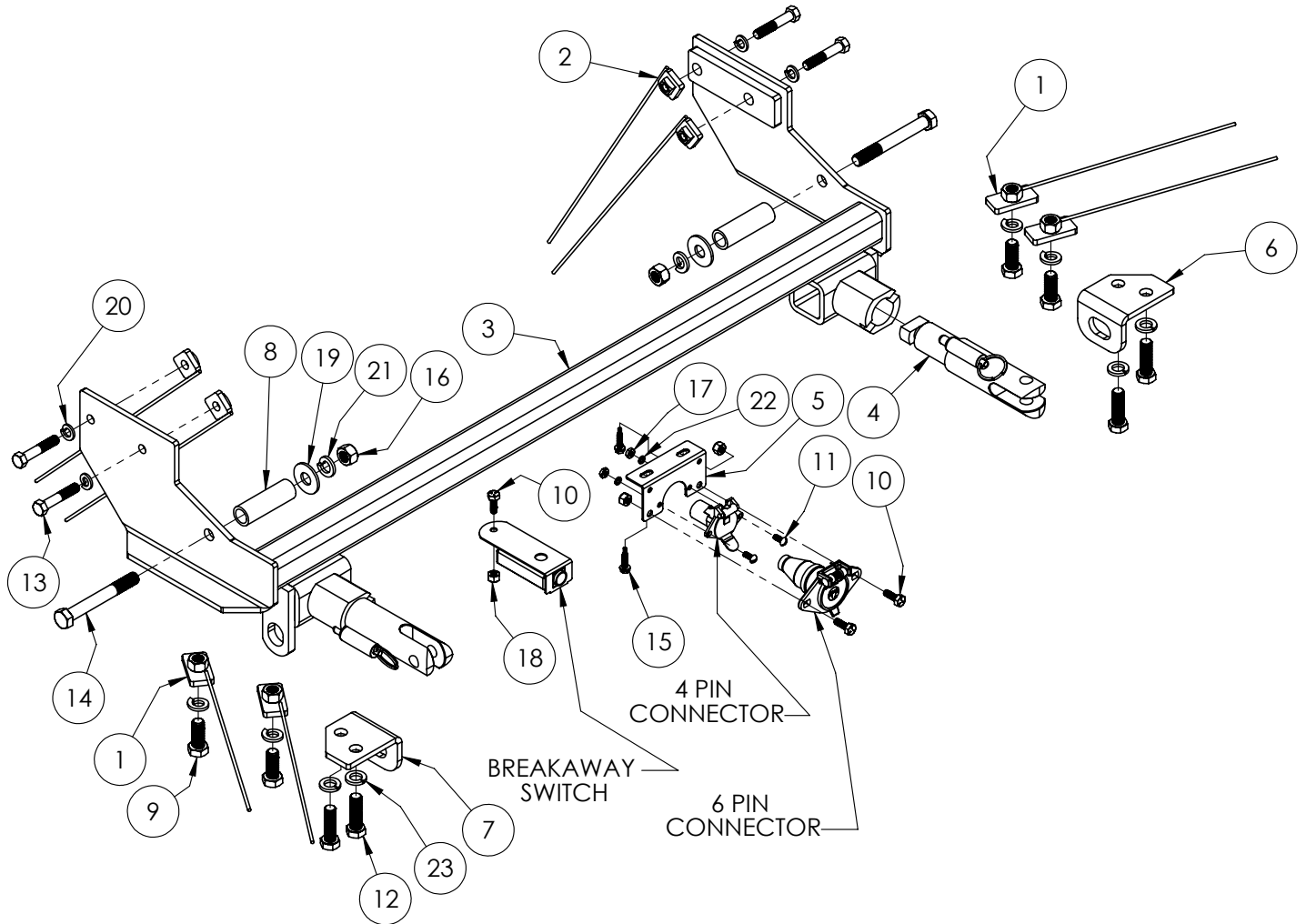

NOTE: Items #7 and #8 need to be rotated 180° for 2011-2012 models so the holes face inward. Remove existing tie down brackets prior to installing the convenience links that have been supplied with your baseplate.

IMPORTANT: Use only genuine factory replacement parts on your baseplate. Do not substitute homemade or nontypical parts. If a bolt is lost or in need of replacement, for your safety and the preservation of your baseplate, be sure to use a replacement bolt of the same grade (usually grade 5, refer to parts list). Repair parts may be ordered through your nearest Blue Ox® dealer or distributor.

BX3763

2005-2015 Toyota Tacoma (Includes Prerunner)

Installation Instructions

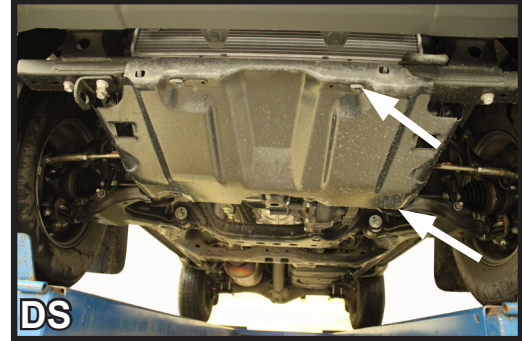
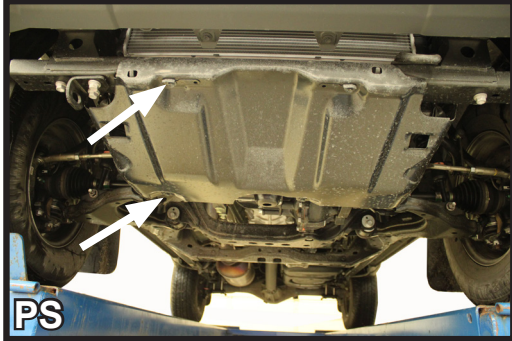

1. Using a 12MM socket remove the four (4) bolts, two (2) per side, from the belly pan and set aside for reinstalling after baseplate installation. **NOTE:** Some models may not have a belly pan.

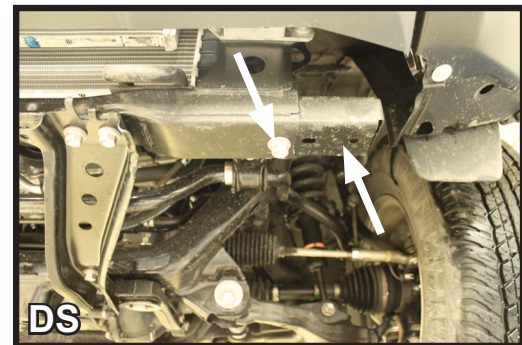
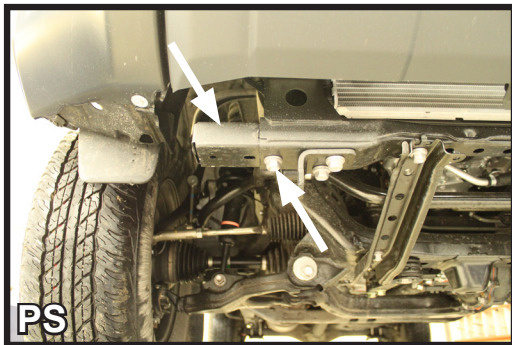

2. On 2011-2012 models only, locate the frame extension, remove the bolt using a 12MM socket and slide outer tube out. The outer tubes will not be reinstalled.

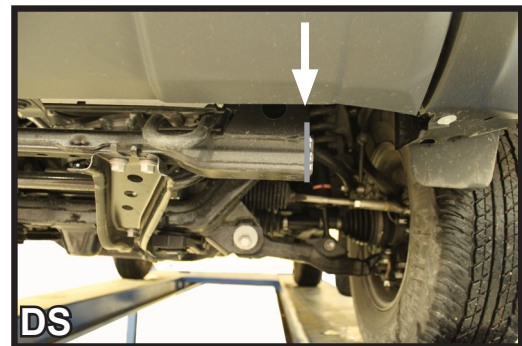
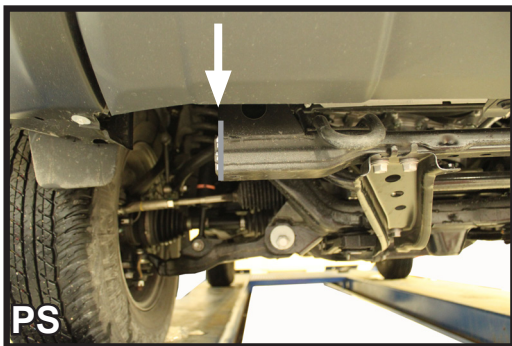

3. Locate the frame extension, with a reciprocating saw remove the end portion of the cross member slightly so it is flush with the tab. Be sure to paint edges with a high quality paint in order to prevent rusting.

BX3763
2005-2015 Toyota Tacoma
(Includes Prerunner)
Installation Instructions



4. Remove the two (2) push pins from the bottom edge of the front fascia. After removing the push pins, use a rubber mallet to bend the tabs upward where the push pins were located. This will prepare the opening for the baseplate installation.

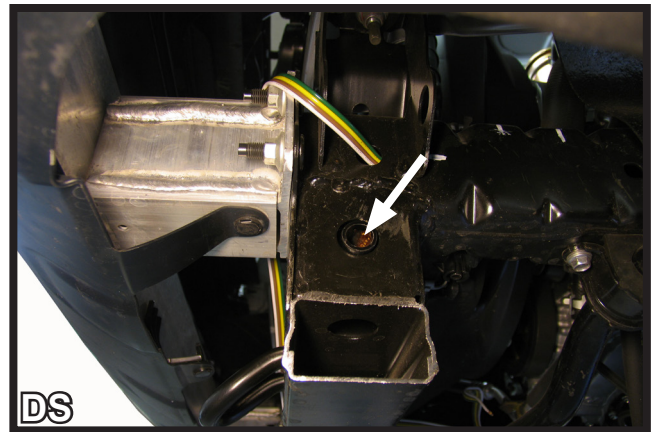
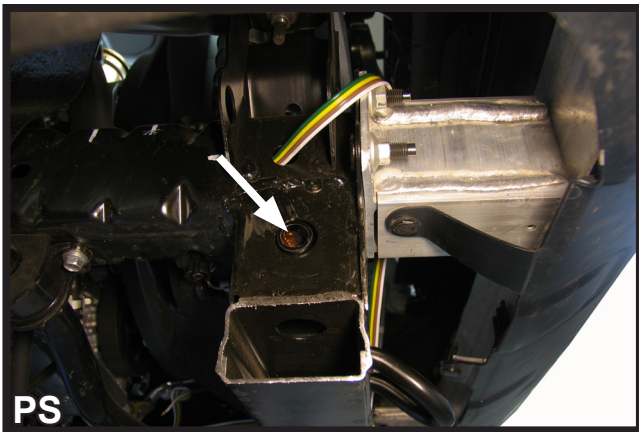

5. Insert the 7/8" O.D. spacer tube (item #9) into the opening in the side of the lower extension below the frame end so it is flush.



BX3763

2005-2015 Toyota Tacoma (Includes Prerunner)

Installation Instructions

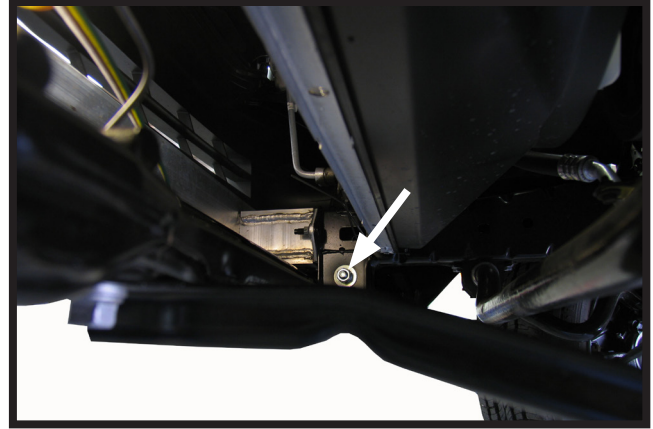

6. Tilt the back of the baseplate down, slide cross tube between the tie down loops and the tab. Align the forward hole of the baseplate with the existing hole of the lower extension that has the 7/8" O.D. spacer tube inserted. Place the 1/2" x 4" hex bolts through the outside of the baseplate and hand tighten.

Insert the removable attachment tabs into baseplate, align tabs level with the vehicle, clamp end plates to frame with vise grips and tighten 1/2" hex nuts on both sides. Be sure to use Loctite® Red on all bolts prior to tightening. Tighten all bolts according to the torque chart.

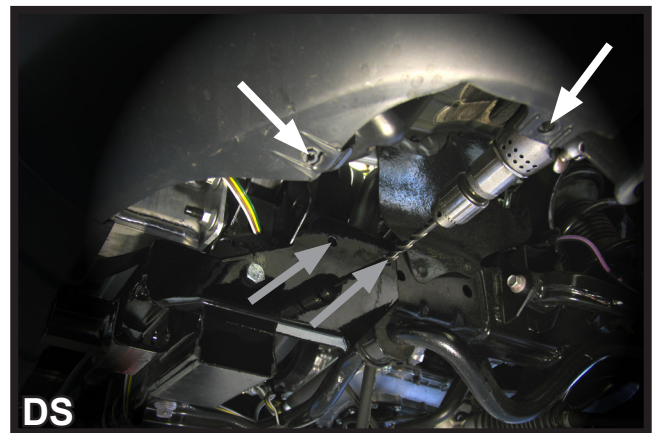
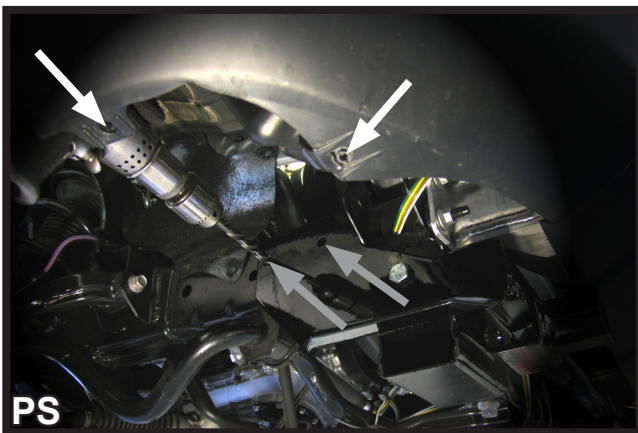

7. Ahead of the front tire on the bottom edge of the fascia are two (2) bolts, remove these with a 10MM socket. Unsnap well wheel liner from the lower fascia and pull forward. This will allow room to drill. Using the upper holes on the baseplate as a template, drill two (2) holes into the side of the frame rail with a 13/32" drill bit.



BX3763
2005-2015 Toyota Tacoma
(Includes Prerunner)
Installation Instructions

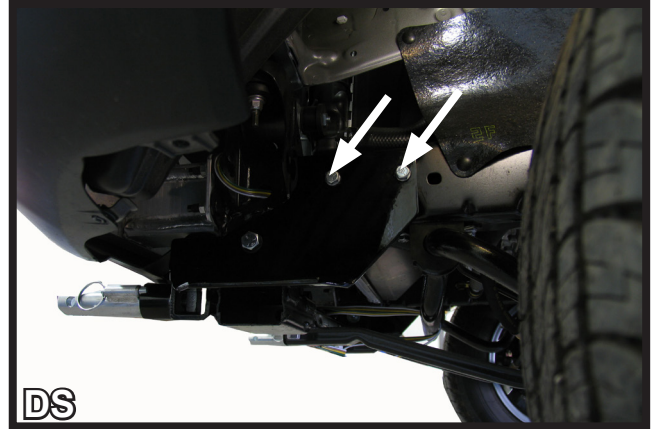
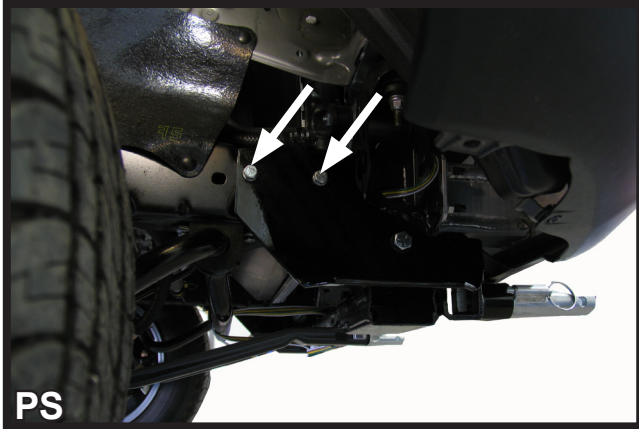

8. Insert 3/8"-16 x 2" bolts with 3/8" lock washers into the holes from the outside of the frame.

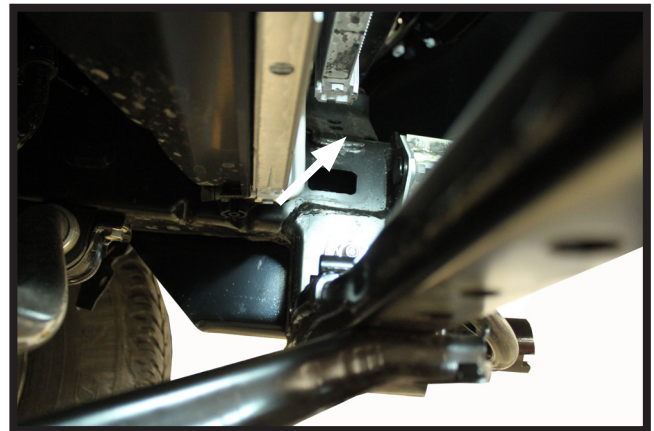

9. On the inside of the frame, remove the cap on BOTH sides of the vehicle. Install 3/8-16 nut plates onto the 3/8" x 2" bolts from step #8. Fully tighten all bolts and reinstall the caps.



BX3763

2005-2015 Toyota Tacoma (Includes Prerunner)

Installation Instructions



10. Align the electrical bracket with the center of baseplate cross tube, install the self tapping screws into the bottom of cross tube with the 5/16" nut driver and drill. Reposition tabs to their original placement and reinstall push pins.



11. Attach the appropriate convenience link to the bottom of each side of the frame as indicated using two (2) 12MM bolts with 12MM lock washers and 1/2" nut plates.



BX3763

2005-2015 Toyota Tacoma (Includes Prerunner)

Installation Instructions

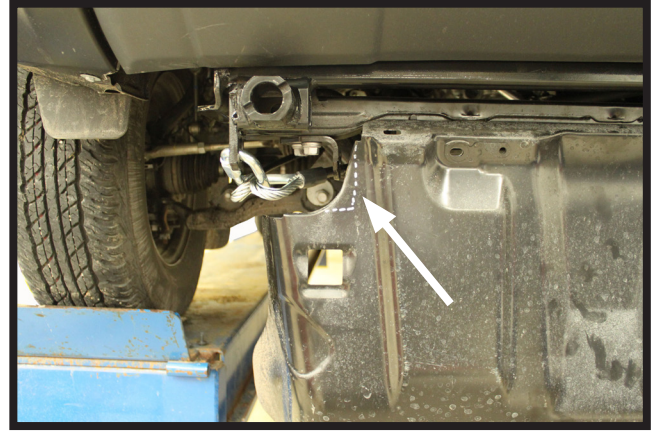

12. Attach the permanent baseplate safety cables to the provided convenience link on the baseplate. The photo above shows the recommended installation of the cables to frame of vehicle. Additional options may interfere with suggested mounting; in this case, secure the cables to a solid piece of the frame as described in the instructions included with the permanent baseplate safety cables. Be sure the safety cables do not rub against any hoses or moving parts. Do this on both sides of the vehicle. NOTE: You will have to square off the belly pan slightly prior to reinstalling it.
13. Dealer or installer be certain the user receives the instruction sheet.

CUSTOMER SERVICE COMMITMENT

Blue Ox is committed to providing you with exceptional customer care throughout your lifetime with our products. Our team is here to assist you with any questions you may have regarding the performance of your product. Simply call (402) 385-3051 and you can speak with our customer care team.

Additionally, please visit our website to see which rallies our Destination America team will be attending. For a nominal fee, our service technician will service your towing system to ensure it's in proper working condition. Also, as a commitment to our customers, should you visit our factory, you can stay at our full service Blue Ox campground at no charge along with enjoying a factory tour.

Again, thank you for being our customer and for the confidence you have shown in the performance of our products. It is because of customers like you we enjoy the success we have today.

© 2011 Blue Ox
One Mill Road, Industrial Park
Pender, Nebraska 68047
Phone: (402) 385-3051
Fax: (402) 385-3360
www.blueox.com

General Information

1. Ensure that your product(s) are registered online at www.blueox.com. It is crucial to register your product(s) so that you may be alerted of product offerings, updates, upgrades, maintenance and safety bulletins, and/or recalls.
2. **It is the owner's responsibility to inspect all towing equipment for cracked welds, missing or worn parts and loose bolts before each towing trip.** Be sure to use Loctite® Red on all bolts and tighten to the recommended specifications.
3. **It is the owner's responsibility to hook up all towing equipment per manufacturer's instructions/recommendations.**
4. Remove the attachment tabs when not in use (if applicable).

Notice To Baseplate Installer

1. It is YOUR responsibility to watch for:

- Oil cooler and air conditioner lines
- Electrical wires and hoses
- Missing parts or attaching points on the frame

** If the baseplate is improperly installed and is against a wire or hose, it could cause fluid leaks or electrical shorts some time after the actual baseplate installation.

Permanent Baseplate Safety Cable Installation

Permanent baseplate safety cables are strongly recommended when towing a vehicle with a tow bar. The principle function of the permanent baseplate safety cables is to prevent the towed vehicle from breaking loose in the event the connection between the frame of the towed vehicle and the baseplate fails or becomes disconnected. The cables must be connected from the baseplate to the frame rail or cross member of the vehicle's frame. The illustrations below show the possible arrangements recommended by Blue Ox®. Each permanent baseplate safety cable must have an adequate weight rating for the towing system. The weight rating of the two (2) cables together will not qualify.

Do not mount the permanent baseplate safety cables against wires, hoses or brake lines.

These permanent baseplate safety cables should remain installed as long as the baseplate is installed on the vehicle. Permanent baseplate safety cables are to be used in conjunction with, and NOT a replacement for legally required safety cables attaching the towed vehicle to the towing vehicle.

OPTION #1

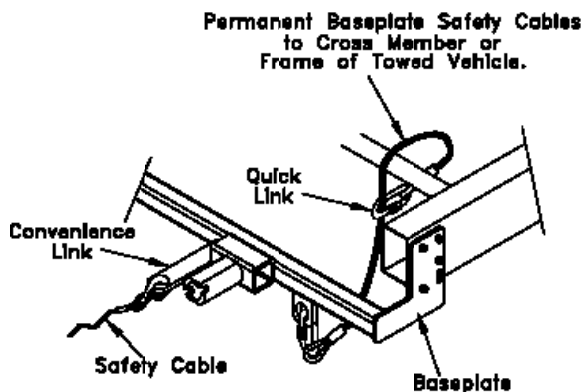

OPTION #2

