



Strong As An Ox™

BX3612 Installation Instructions 2003-05 Subaru Forester AWD

Serial No.

The front fascia, tie down brackets and fog lights are removed for baseplate installation. Drilling is required. The BX8869 is available for the vehicle. Attachment Tabs are 20 inches center to center and a height of 15 inches.



1. Unsnap the two clips on the upper grill, pull forward, unsnap one clip in the center of the grill and set grill aside. Remove the four push pins from the top side of fascia.

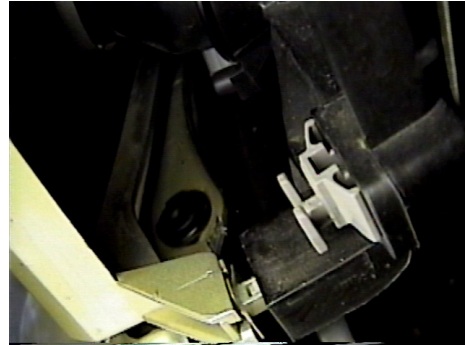

2. Unsnap clip on fascia just inside headlights, both sides. Remove five push pins from the top of metal bumper.



3. Just above fog lights remove one metric bolt with the 10MM socket and one push pin, both sides.



4. Just forward of front tire is one push pin to remove, both sides. Remove four push pins from the bottom of front fascia.

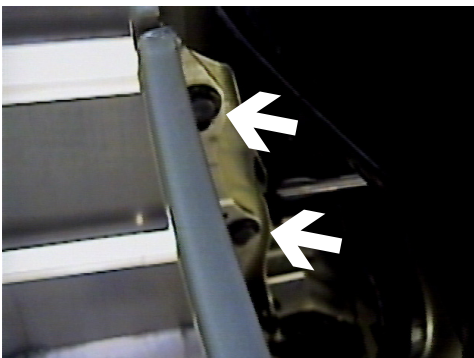

5. Just forward of front tire, pull wheel well back and remove two push pins from fascia's corner, both sides. Pull fascia corner to the side and forward, disconnect electrical plugs and set aside.

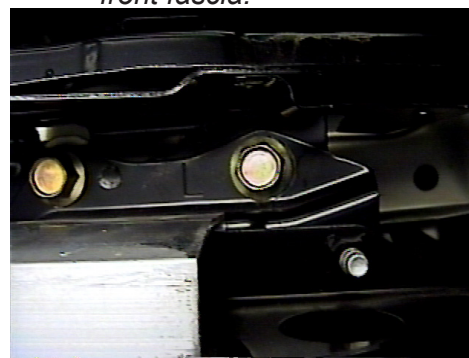

6. Using the 14MM socket, remove three metric bolts from bumper bracket, both sides, pull forward and set aside.



Strong As An Ox™

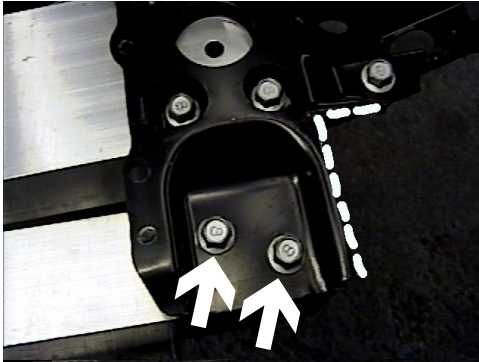

7. Set front bumper face down on flat surface and remove two lower metric bolts with the 13MM socket, both sides. Discard lower tube. Using the hack saw, cut side brace off, according to photo, to relieve area for baseplate on frame sides and cut webbing just behind bumper bracket (see arrow on photo step 9).

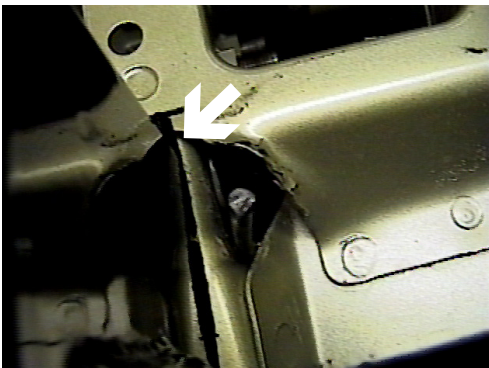

9. Using the pry bar, open area to insert item 4 to align with drilled hole and install items 6 and 7, both sides. Install lower bolt, items 4, 6 and 7, both sides. **Be sure and use loctite on all bolts before tightening.**

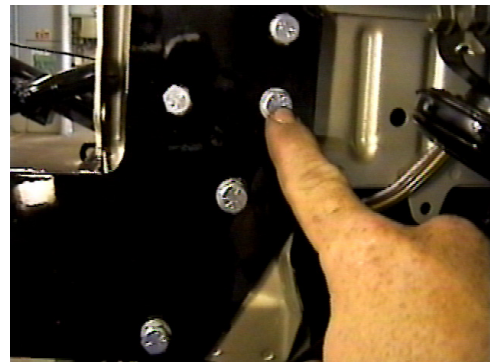

8. **2003 Model:** Remove existing metric bolt from outside of frame rail and discard, both sides. Align item 1 with existing threaded holes on frame, slide item 2 between frame and item 1. Install items 8 and 9, both sides. **2004 Model:** Align the back tow holes on baseplate end with the existing holes in frame, clamp in place with vise grips and level baseplate on vehicle. Using the baseplate as a template, drill out these two holes with the 13/32" drill bit. Install 3/8 x 1 1/2" hex bolts and lock washers into baseplate, insert nut plates into frame end to align with bolts and tighten. **Be sure and use loctite on all bolts before tightening.** Drill remaining holes in baseplate with the 13/32" drill bit. Insert item 3 into frame end and install items 5 and 7. **Be sure and use loctite on all bolts before tightening. Tighten all bolts according to Torque Chart in the General Instruction sheet.**

10. Reinstall bumper, fascia and upper grill. Be sure all electrical connections are plugged in properly.

11. The dimensional variations between otherwise identical cars can be considerable. While the location and size of the holes in the baseplate were designed to allow for easy installation, it may be necessary to file a hole slightly to allow a bolt to clear.

12. Install the tow bar and safety cables according to the instructions included in their packages.

13. Do **not** substitute other devices if the tow bar pin and clip are lost.

14. **DEALER OR INSTALLER: BE CERTAIN THE USER RECEIVES THE INSTRUCTION SHEET.**



Strong As An Ox™

Tools Required

9/16" Socket
13mm Socket
Hack Saw

Loctite
14MM Socket
Pry Bar

10MM Socket
13/32" Drill Bit

Parts List

Ref. No.	Qty.	Part No.	Description
1	1	61-5830	Weldment, Base Plate, BX3612
2	2	102-6328	Spacer Plate, BX3612
3	6	61-5208	3/8-16 Nut Plate
4	4	61-4978	3/8-16 Whiz Nut, with 14 Inch Wire
5	6	201-0440	3/8-16 x 1 1/2 Bolt, Grd. 5, ZP
6	4	201-0368	3/8-16 x 1 1/4 Bolt, Grd. 5, ZP
7	6	203-0010	3/8 Lock Washer, ZP
8	4	201-0418	8MM-1.25 x 35MM Hex Bolt, Grd 8.8, ZP
9	4	203-0102	8MM Lock Washer, ZP
10	2	201-0979	#12-14 x 1" Self Drilling Screw, ZP
11	2	101-5822	Adapter, 4 Way Connector
12	2	201-0192	#10-32 x 1/2 Slot, Rd. Hd. Screw
13	2	203-0054	#10 Lock Washer
14	2	202-0047	#10-32 Hex Nut
15	2	62-3468	Attachment, Assembly, SF/ SB (One Hole)
	2	226-0046	Baseplate Safety Cable, 36" CL III (Not Shown)
	2	229-0359	Quicklink, 3/8, ZP (Not Shown)
	2	290-0437	Receiver, Cap Plug (Blk) (Not Shown)

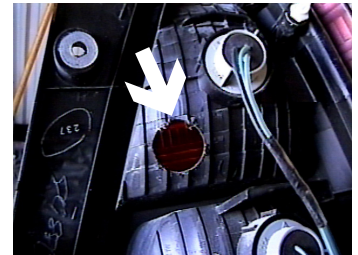
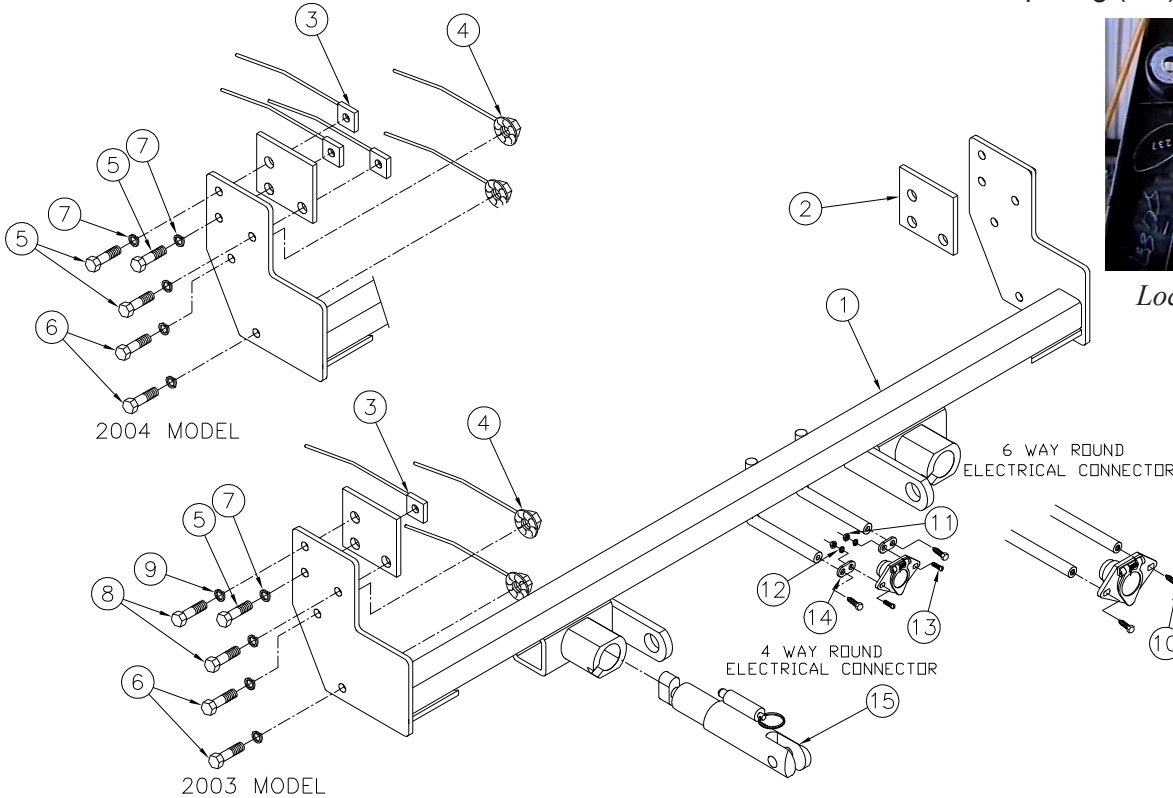

Location for the BX8869 on driver's side.

IMPORTANT: Use only genuine factory replacement parts on your Base Plate. Do not substitute homemade or nontypical parts. If a bolt is lost or in need of replacement, for your safety and the preservation of your Base Plate, be sure to use a replacement bolt of the same grade (Usually Grade 5, refer to parts list). Repair parts may be ordered through your nearest **Blue Ox** dealer or distributor.

General Information

1. Ensure that your product(s) are registered online at www.blueox.com. It is crucial to register your product(s) so that you may be alerted of product offerings, updates, upgrades, maintenance and safety bulletins, and/or recalls.
2. **It is the owner's responsibility to inspect all towing equipment for cracked welds, missing or worn parts and loose bolts before each towing trip.** Be sure to use Loctite® Red on all bolts and tighten to the recommended specifications.
3. **It is the owner's responsibility to hook up all towing equipment per manufacturer's instructions/recommendations.**
4. Remove the attachment tabs when not in use (if applicable).

Notice To Baseplate Installer

1. It is YOUR responsibility to watch for:

- Oil cooler and air conditioner lines
- Electrical wires and hoses
- Missing parts or attaching points on the frame

** If the baseplate is improperly installed and is against a wire or hose, it could cause fluid leaks or electrical shorts some time after the actual baseplate installation.

Permanent Baseplate Safety Cable Installation

Permanent baseplate safety cables are strongly recommended when towing a vehicle with a tow bar. The principle function of the permanent baseplate safety cables is to prevent the towed vehicle from breaking loose in the event the connection between the frame of the towed vehicle and the baseplate fails or becomes disconnected. The cables must be connected from the baseplate to the frame rail or cross member of the vehicle's frame. The illustrations below show the possible arrangements recommended by Blue Ox®. Each permanent baseplate safety cable must have an adequate weight rating for the towing system. The weight rating of the two (2) cables together will not qualify.

Do not mount the permanent baseplate safety cables against wires, hoses or brake lines.

These permanent baseplate safety cables should remain installed as long as the baseplate is installed on the vehicle. Permanent baseplate safety cables are to be used in conjunction with, and NOT a replacement for legally required safety cables attaching the towed vehicle to the towing vehicle.

OPTION #1

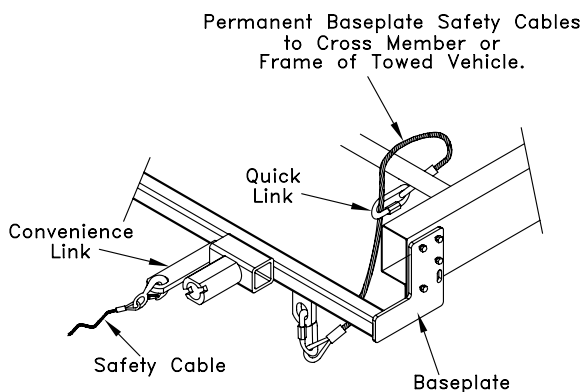

OPTION #2

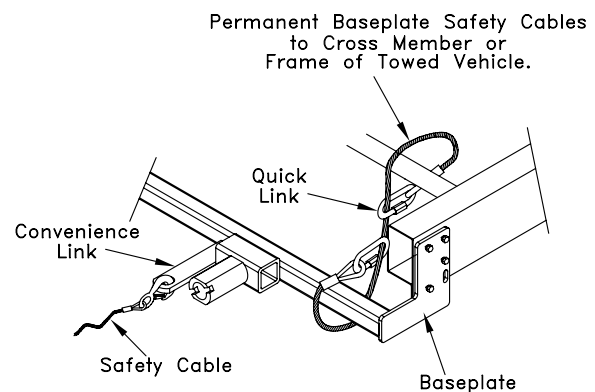

BLUE OX ORIGINAL PURCHASERS ONE YEAR LIMITED WARRANTY

Automatic Equipment Manufacturing Company ("Automatic") warrants to the original (first) retail purchaser that this product, manufactured by Automatic, shall be free from defect in material and workmanship under normal use and service for a period of one year from the date of delivery.

During said one-year period, Automatic will repair or replace any parts that have been returned by the original purchaser, to the factory, transportation prepaid, and in Automatic's sole and absolute opinion found to be defective.

Limitations on Warranty Coverage:

Coverage under this warranty will be valid only if the customer warranty card is returned by the original purchaser within 30 days of purchase.

Coverage under this warranty will be effective only when a copy of the original invoice, showing date and place of purchase, accompanies any claim for warranty. This warranty is NON TRANSFERABLE.

This limited warranty will not cover, in any way or form, any alleged damages caused by incorrect or improper installation, improper use, modification or neglect of product, failure to properly service and maintain, misuse, act of God, accident or failure of the user to follow guidelines contained in the instructional material provided by Automatic.

This warranty does not cover normal wear and tear, paint or rust.

Warrantor assumes no responsibility to the owner for loss of use of product, loss of time, inconvenience or any other damage consequential or otherwise. Including, but not limited to mileage, expense of transporting of product, return shipping expense, mechanics travel time, telephone, road service, towing, and rental during repairs, travel, lodging, loss or damage to personal property or loss of earnings.

REPAIR OR REPLACEMENT AS SET FORTH IN THIS LIMITED WARRANTY IS THE SOLE EXCLUSIVE REMEDY OF THE PURCHASER. AUTOMATIC SHALL NOT BE LIABLE FOR ANY INCIDENTAL OR CONSEQUENTIAL DAMAGES FOR BREACH OF ANY EXPRESS OR IMPLIED WARRANTY ON THIS PRODUCT. EXCEPT TO THE EXTENT PROHIBITED BY APPLICABLE LAW, ANY IMPLIED WARRANTY OF MERCHANTABILITY OR FITNESS FOR A PARTICULAR PURPOSE ON THIS PRODUCT IS LIMITED IN LENGTH TO THE DURATION OF THIS WARRANTY.

Please visit <http://blueox.com/warranty/> to register your warranty

