



BX3505

1991-98 Suzuki Sidekick
4 Door/ 4WD

1996-97 Geo Tracker
4 Door/ 2WD/ 4WD
Installation Instructions

Serial Number

Attachment Tab Height: 12"

Attachment Tab Width: 24"

Please read BOTH these Installation Instructions and the General Instructions before attempting to install or operate this equipment.

1. Blue Ox® towing products and accessories are intended to be installed by Blue Ox® Dealers who are familiar with our products and have the equipment necessary and knowledge to do "fit work". When necessary Blue Ox® Dealers can be found at www.blueox.us or by contacting our Customer Care Department at (402) 385-3051 or toll free (888) 425-5382.
2. Many Blue Ox® Baseplates are designed to use existing holes and hardware to mount the baseplate to the towed vehicle. Even though bolts are there, do not assume they are adequate for baseplate mounting. Always use hardware supplied in the hardware kit and existing hardware specified in the Baseplate Installation Instructions.

Bolt Torque Specifications

Torque in Foot-Pounds for Inch Bolts

Bolt Size	Grade 5	Grade 8
1/4"	10	14
5/16"	19	29
3/8"	33	47
7/16"	54	78
1/2"	78	119
5/8"	154	230
3/4"	257	380

Bolt Torque Specifications

Torque in Foot-Pounds for Metric Bolts

Bolt Size	Grade 8.8	Grade 10.9
6MM	6	8
8MM	16	22
10MM	31	40
12MM	54	70
14MM	89	117
16MM	161	230
18MM	222	318

Confirm the towability and pre-towing procedures for your vehicle with the owner's manual or contact the vehicle's manufacturer for specific towing procedures.

! WARNING

Failure to read and follow these instructions could result in separation of the towed vehicle from the tow bar, causing property damage, loss of towed vehicle, personal injury or death.

BX3505

1991-98 Suzuki Sidekick (4 Door/ 4WD)

1996-97 Geo Tracker (4 Door/ 2WD & 4WD)

Installation Instructions

Parts List

Ref. No.	Qty.	Part #	Description
1	2	201-0011	1/2" x 1 1/4" Hex Head Bolt, Grade 5
2	4	203-0012	1/2" Lock Washer
3	2	61-4029	Weldment, 1/2" Nut Wire
4	2	201-0068	1/2" x 1 3/4" Hex Head Bolt, Grade 5
5	2	61-3522	Weldment, Nut Holder, BX3505
6	1	61-3521	Weldment, Baseplate, BX3505
7	2	203-0102	8MM Lock Washer
8	2	201-0446	8MM-1.25 x 30MM Hex Bolt, Grade 8.8
9	2	203-0003	3/8" Flat Washer
	2	226-0046	Baseplate Safety Cable, 36" CL III (Not Shown)
	2	229-0359	Quicklink, 3/8, ZP (Not Shown)

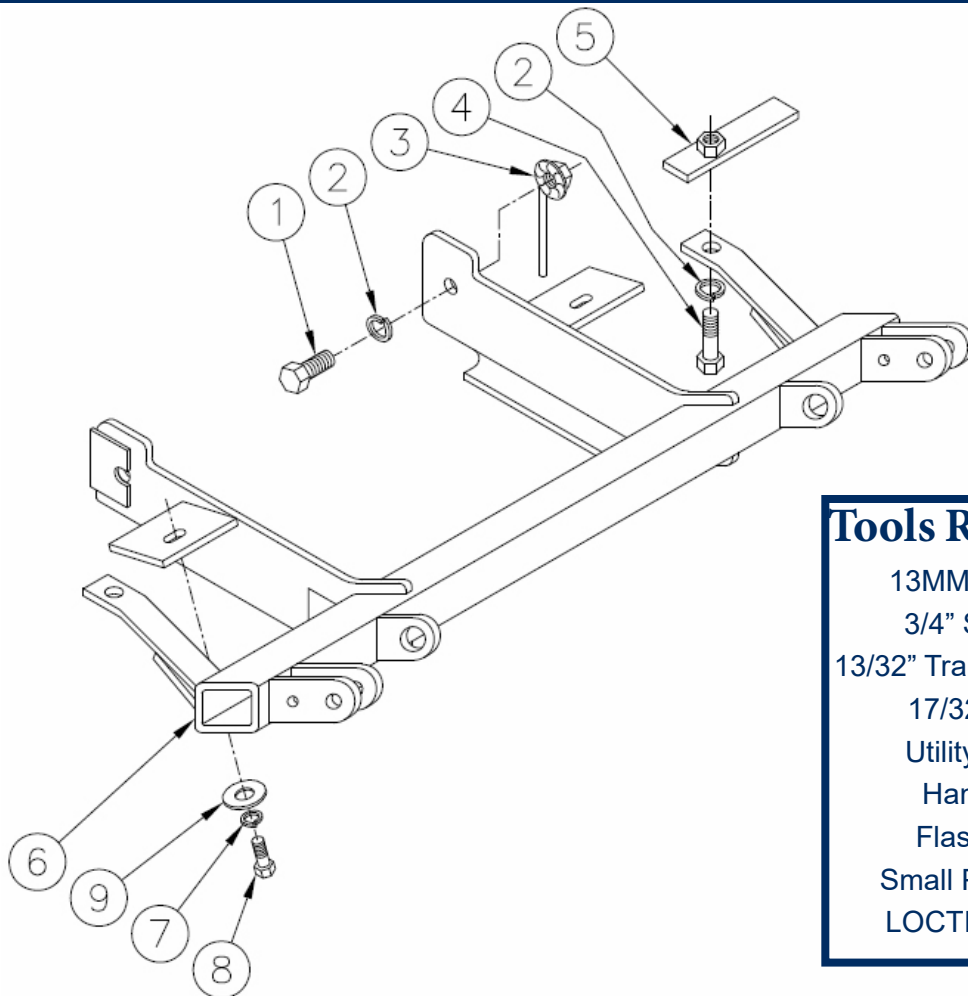

Tools Required

- 13MM Socket
- 3/4" Socket
- 13/32" Transfer Punch
- 17/32" Drill
- Utility Knife
- Hammer
- Flashlight
- Small Pilot Drill
- LOCTITE Red

Important:

Use only genuine factory replacement parts on your baseplate. Do NOT substitute homemade or non-typical parts. If a bolt is lost or in need of replacement, for your safety and the preservation of your baseplate, be sure to use a replacement bolt of the same grade (In most cases it will be Grade 5, please reference the parts list above). Replacement parts may be ordered through your nearest Blue Ox® Dealer or Distributor, or call our Customer Care Team at (402)385-3051.

BX3505

1991-98 Suzuki Sidekick (4 Door/ 4WD) 1996-97 Geo Tracker (4 Door/ 2WD & 4WD)

Installation Instructions

Standard Tab Spacing Guidelines:

To use certain adapters or a RangeFinder II tow bar in conjunction with standard tab baseplates an additional 5/16" hole must be drilled in the attachment tabs. The Ambassador tow bar will require an adapter for attachment tabs that are not 24" wide. The Adventurer tow bar will require an adapter for attachment tabs that are less than 24" wide. The Acclaim tow bar will not fold and store without the use of an adapter on vehicles with attachment tabs less than 24" wide.

Instructions:

Installation of this baseplate requires trimming of the inside plastic bumper (Geo Tracker). Drilling is required.

The dimensional variations between otherwise identical vehicles can be considerable. While the baseplate was designed for easy installation, it may be necessary to tailor the baseplate slightly to compensate for auto manufacturer's tolerances. These minor adjustments may include filing a hole slightly, bending electrical rods, and/ or bending end plates.

Installation Instructions

1. Read the Baseplate General Instructions Sheet included with this baseplate.
2. The baseplate mounts to the front underside of the chassis using six bolts, three on each side of the vehicle. These bolts are provided with the baseplate.
3. The baseplate has two heavy inside arms and two outside struts. The inside arms slide up between the two vertical towers of the vehicle which are the forward attachment points for the suspension "A" arms. Properly positioned, the tow bar attachment tabs will angle up.
4. Just behind the bumper there is a chassis cross beam with two vertical threaded holes. The two smallest baseplate holes align with these 8MM holes.
5. On the Geo Tracker, there is a plastic bumper, which ends just forward of the 8Mm holes. This plastic must be compressed up against the bottom of the frame to install the baseplate. On the inside of the plastic, there are three vertical ribs which will prevent the plastic from being compressed. These ribs need to have approximately one inch trimmed off to allow the plastic to be pushed flat against the bottom of the frame.
6. Using the two 8MM bolts provided, temporarily position the baseplate by inserting and firmly tightening the bolts.

BX3505

1991-98 Suzuki Sidekick (4 Door/ 4WD) 1996-97 Geo Tracker (4 Door/ 2WD & 4WD)

Installation Instructions

7. Using the baseplate as a template, take a 17/32" transfer punch and center punch the four large holes on the chassis to match those on the baseplate. There are two horizontal holes on the inside of the "A" arm towers (located by the heavy arms), and two vertical holes on the chassis cross beam (located by the struts).
8. Remove the baseplate and pilot drill all four holes through one side **ONLY**. Finish drilling using a 17/32" diameter drill. Remove the burrs.
9. Reposition the baseplate loosely with the 8MM bolts, 8MM lock washers, and 3/8" flat washers. **Apply LOCTITE Red to ALL bolt threads.**
10. Insert the 1/2" x 1 1/4" bolts into the two horizontal holes on the heavy arms using 1/2" lock washers and LOCTITE Red. Slide the 1/2" nut wires up inside the tower. Start the bolts and secure loosely.
11. Verify that the 1/2" x 1 3/4" bolts engage the nut plates.
12. Slide each of the nut plates up inside the chassis cross beam using the oval holes just forward and outside the struts for access. The short side of the plate goes in first and the nut is on top. Using a flashlight, position the plate so the nut is directly above the strut hole. Place a 1/2" lock washer and LOCTITE Red on each 1/2"x 1 3/4" bolt and hand start each bolt into the vertical strut holes and the nut plates.
13. **TIGHTEN ALL BOLTS FIRMLY.**

The dimensional variations between otherwise identical cars can be considerable. While the location and size of the holes in the baseplate were designed to allow for easy installation, it may be necessary to file a hole slightly to allow a bolt to clear.

Install the tow bar and safety cables according to the instructions included in their packages.

Do not substitute other devices if the tow bar pin and clip are lost.

DEALER OR INSTALLER: BE CERTAIN THE USER RECEIVES THE INSTRUCTION SHEETS.

BX3505

1991-98 Suzuki Sidekick (4 Door/ 4WD) 1996-97 Geo Tracker (4 Door/ 2WD & 4WD)

Installation Instructions

CUSTOMER SERVICE COMMITMENT

Blue Ox is committed to providing you with exceptional customer care throughout your lifetime with our products. Our team is here to assist you with any questions you may have regarding the performance of your product. Simply call 1-800-228-9289 and you can speak with our customer care team.

Additionally, please visit our website to see which rallies our Destination America team will be attending. For a nominal fee, our service technician will service your towing system to ensure it's in proper working condition. Also as a commitment to our customers, should you visit our factory you can stay at our full service Blue Ox campground at no charge along with enjoying a factory tour.

Again thank you for being our customer and for the confidence you have shown in the performance of our products. It is because of customers like you we enjoy the success we have today.



© 2006 Blue Ox
One Mill Road, Industrial Park
Pender, Nebraska 68047
Phone: (402) 385-3051
Toll Free: (888) 425-5382
Fax: (402) 385-3360
www.blueox.us

General Information

1. Ensure that your product(s) are registered online at www.blueox.com. It is crucial to register your product(s) so that you may be alerted of product offerings, updates, upgrades, maintenance and safety bulletins, and/or recalls.
2. **It is the owner's responsibility to inspect all towing equipment for cracked welds, missing or worn parts and loose bolts before each towing trip.** Be sure to use Loctite® Red on all bolts and tighten to the recommended specifications.
3. **It is the owner's responsibility to hook up all towing equipment per manufacturer's instructions/recommendations.**
4. Remove the attachment tabs when not in use (if applicable).

Notice To Baseplate Installer

1. It is YOUR responsibility to watch for:

- Oil cooler and air conditioner lines
- Electrical wires and hoses
- Missing parts or attaching points on the frame

** If the baseplate is improperly installed and is against a wire or hose, it could cause fluid leaks or electrical shorts some time after the actual baseplate installation.

Permanent Baseplate Safety Cable Installation

Permanent baseplate safety cables are strongly recommended when towing a vehicle with a tow bar. The principle function of the permanent baseplate safety cables is to prevent the towed vehicle from breaking loose in the event the connection between the frame of the towed vehicle and the baseplate fails or becomes disconnected. The cables must be connected from the baseplate to the frame rail or cross member of the vehicle's frame. The illustrations below show the possible arrangements recommended by Blue Ox®. Each permanent baseplate safety cable must have an adequate weight rating for the towing system. The weight rating of the two (2) cables together will not qualify.

Do not mount the permanent baseplate safety cables against wires, hoses or brake lines.

These permanent baseplate safety cables should remain installed as long as the baseplate is installed on the vehicle. Permanent baseplate safety cables are to be used in conjunction with, and NOT a replacement for legally required safety cables attaching the towed vehicle to the towing vehicle.

OPTION #1

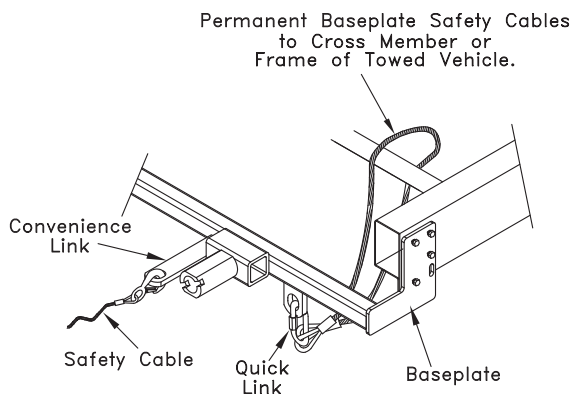

OPTION #2

