

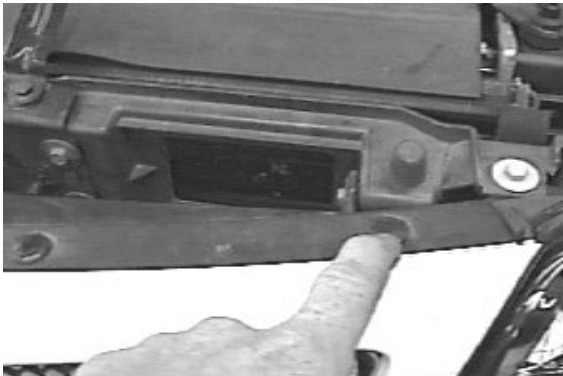

BX3220 Installation Instructions
2001 Oldsmobile Aurora, V-6/ 3.5L,

Serial No.

The front bumper is removed for baseplate installation. Holes need to be drilled. Fascia will be trimmed. The attachment tabs are centered at 24 inches. Use Loctite on all bolts.



1. Lift hood and remove push pins holding top of the bumper fascia.



2. Remove the push pins from the wheel well molding forward of the tires.

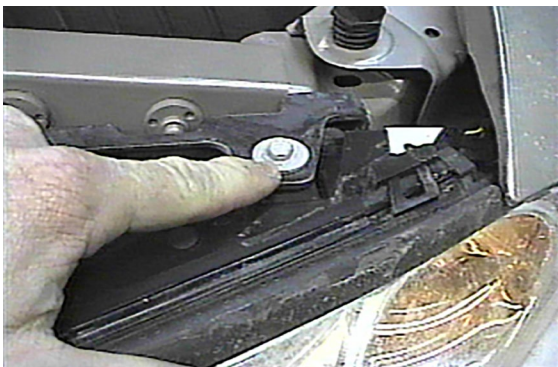

3. Remove two 10MM bolts, each side from head light fixture, unplug, and pull forward. Set light fixture aside.



4. There are two 10MM bolt, to remove each side, behind light fixture that hold fascia to fender.



5. Pull out the wheel well molding and remove the 10 MM bolt connecting the fascia and the fenders.

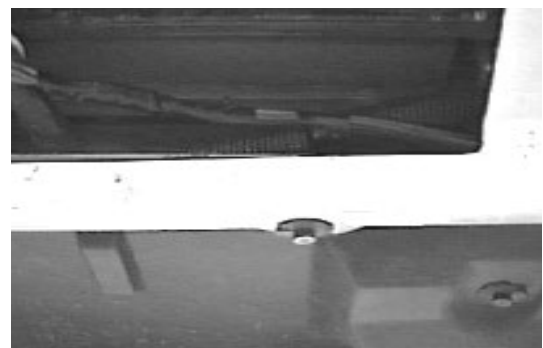

6. Remove the 10mm bolts from the bottom of the bumper fascia. Pull bumper fascia forward and set aside. Be sure fog lights are unplugged if available.

Automatic

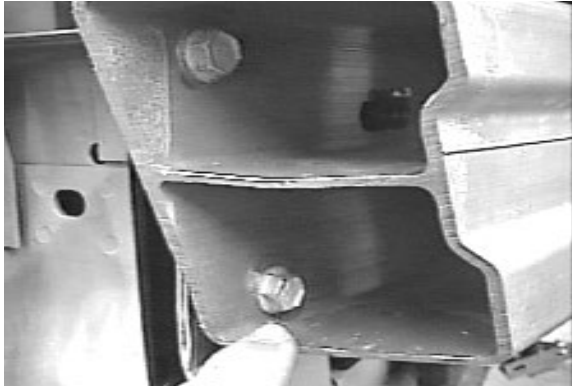

7. Remove the outside bolts from each side of the bumper.

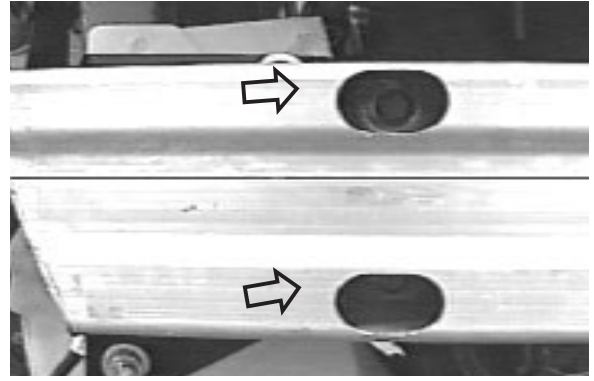

8. Remove the bolts from the bumper exposed by the slots on each side.



9. Remove the plastic bolt plate from each side of the vehicle. It will not be used for the baseplate installation.

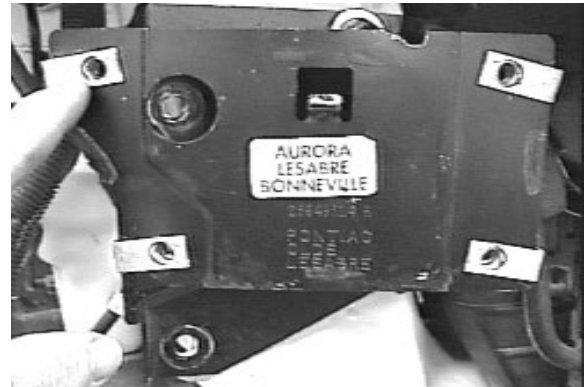

10. Remove the four clips from each bracket. They will not be used in baseplate installation.

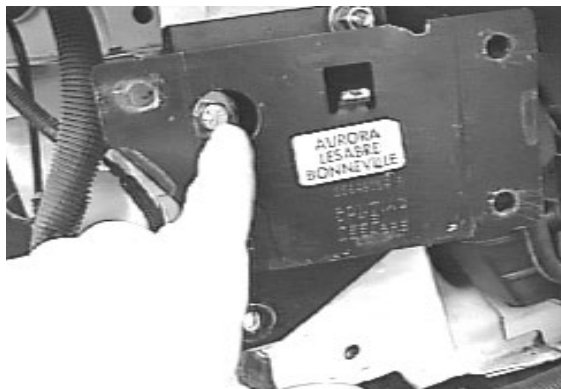

11. Install the bolt and its hardware as shown. Tighten according to chart in the General Instruction Sheet and be sure to use loctite on all bolts.

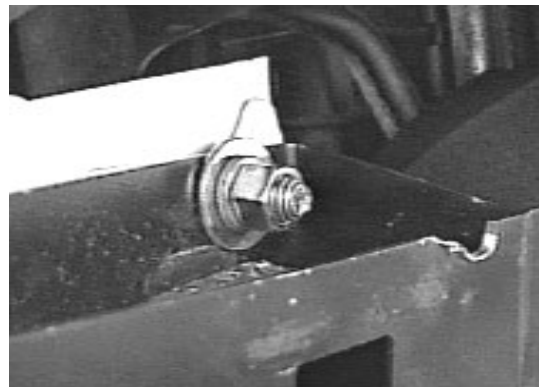

12. Drill a 3/8" hole through the bumper bracket and the frame, use 3/8" hardware as shown in drawing on page 4. Use loctite on all bolts.

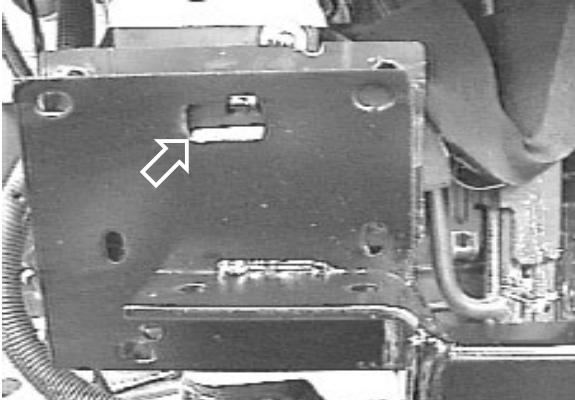

13. Set the baseplate on the hooks of the brackets. Insert both of the top bolts through the baseplate and bracket. Use appropriate hardware on bolt and hand tighten. Do the same for the other side.

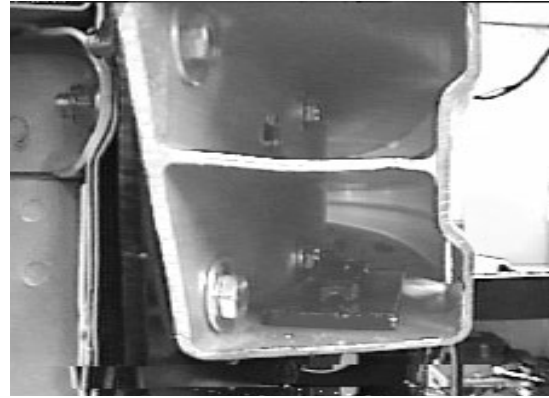

14. Set the bumper on the baseplate. Install the rest of the hardware for the remaining holes. Be sure and use loctite on all bolts.

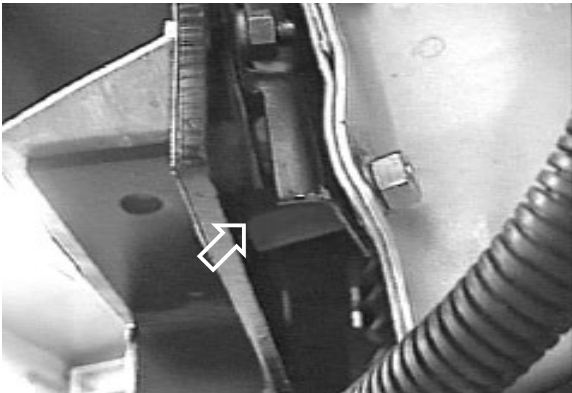

15. Be sure to place the tube spacer between the frame and the baseplate. Once all bolts have been started tighten according to the chart in the General instruction Sheet. Use loctite on all bolts.

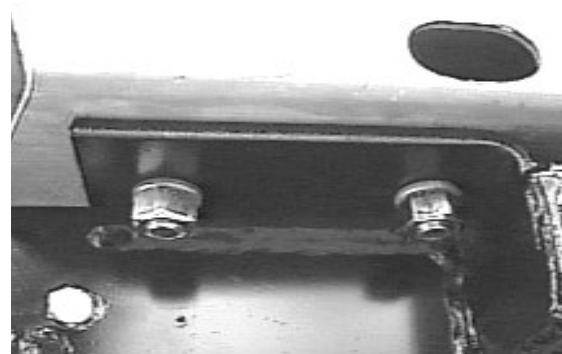

16. Use baseplate as template and drill 3/8" holes. Insert boltplates into bumper placing bolts through the drilled holes. Use appropriate hardware and tighten bolts. Be sure and use loctite on all bolts.



17. Hold the bumper fascia up to its original position and mark on the grill where it needs to be trimmed. Once this is done replace fascia, light fixtures, and connect any electrical connections.

IMPORTANT: Use only genuine factory replacement parts on your Base Plate. Do not substitute homemade or nontypical parts. If a bolt is lost or in need of replacement, for your safety and the preservation of your Base Plate, be sure to use a replacement bolt of the same grade (Usually Grade 5, refer to parts list).

Repair parts may be ordered through your nearest **Automatic Blue Ox** dealer or distributor.

18. Install the tow bar and safety cables according to the instruction included in their packages. Do not substitute other devices if the tow bar pin and clip are lost.

19. **DEALER OR INSTALLER: BE CERTAIN THE USER RECEIVES THE INSTRUCTION SHEET.**

Tools Required

13mm Socket
Utility Knife

Loctite Blue
15mm Socket

3/8" Drill Bit
10mm Socket

9/16" Wrench

Parts List

Ref. No.	Qty.	Part No.	Description
1	1	61-5572	Weldment, Base Plate, BX3220
2	2	61-5535	Weldment Bolt Plate, 1/2-13 x 1
3	8	201-0368	3/8-16 x 1 1/4 Bolt, Hex Grd. 5 ZP
4	4	201-0440	3/8-16 x 1 1/2 Bolt, Hex Grd. 5 ZP
5	2	201-0336	3/8-16 x 2 1/2 Bolt, Hex Grd. 5 ZP
6	14	203-0003	3/8 Flat Washer, ZP
7	14	203-0010	3/8 Lock Washer, ZP
8	14	202-0003	3/8-16 Hex Nut, ZP
9	2	107-2339	Tube, Spacer, 1 Inch x 5/8 Dia.
10	4	203-0012	1/2 Lock Washer, ZP
11	4	202-0005	1/2-13 Hex Nut, ZP
	2	226-0046	Baseplate Safety Cable, 36" CL III (Not Shown)
	2	229-0359	Quicklink, 3/8, ZP (Not Shown)

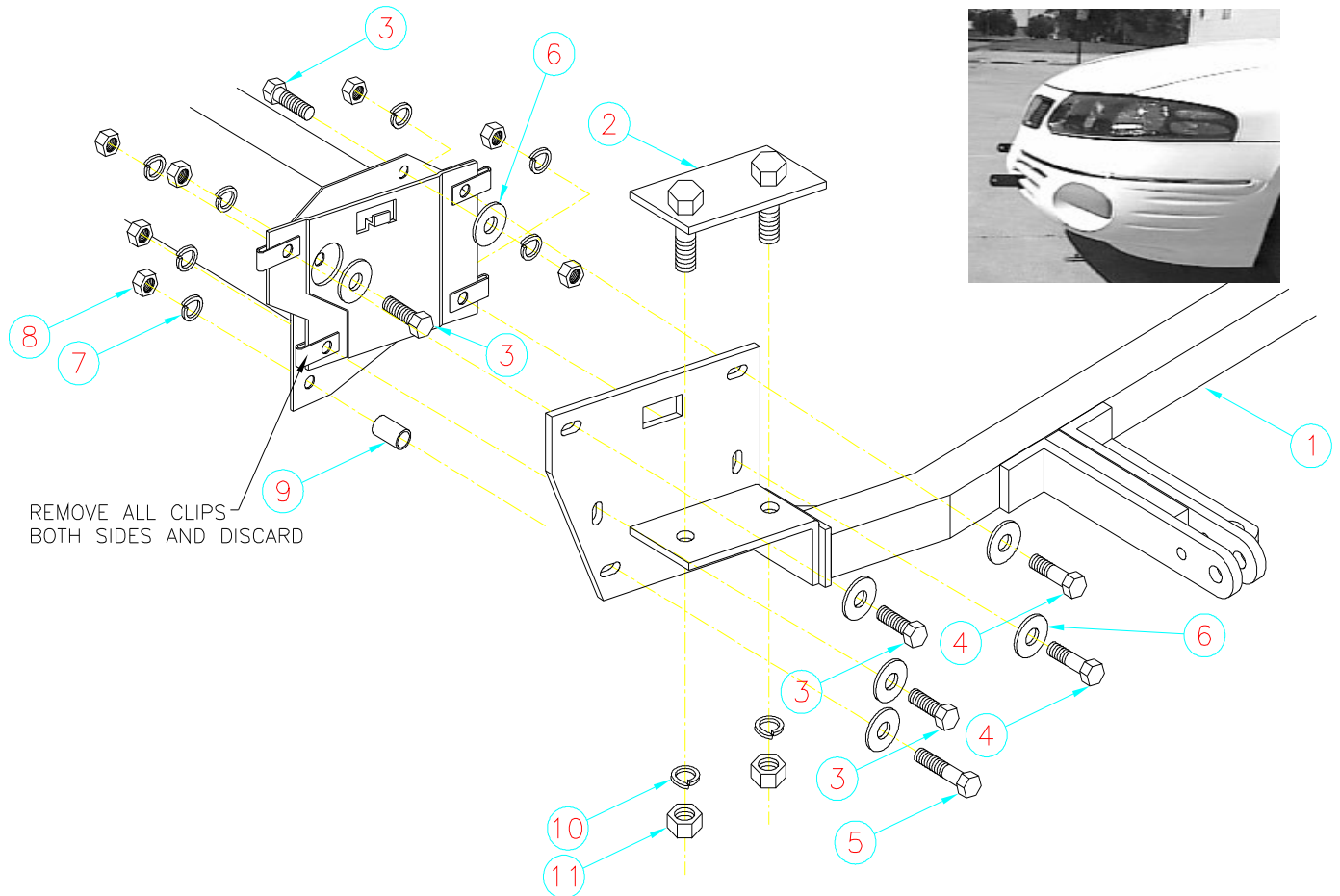

General Information

1. Ensure that your product(s) are registered online at www.blueox.com. It is crucial to register your product(s) so that you may be alerted of product offerings, updates, upgrades, maintenance and safety bulletins, and/or recalls.
2. **It is the owner's responsibility to inspect all towing equipment for cracked welds, missing or worn parts and loose bolts before each towing trip.** Be sure to use Loctite® Red on all bolts and tighten to the recommended specifications.
3. **It is the owner's responsibility to hook up all towing equipment per manufacturer's instructions/recommendations.**
4. Remove the attachment tabs when not in use (if applicable).

Notice To Baseplate Installer

1. It is YOUR responsibility to watch for:

- Oil cooler and air conditioner lines
- Electrical wires and hoses
- Missing parts or attaching points on the frame

** If the baseplate is improperly installed and is against a wire or hose, it could cause fluid leaks or electrical shorts some time after the actual baseplate installation.

Permanent Baseplate Safety Cable Installation

Permanent baseplate safety cables are strongly recommended when towing a vehicle with a tow bar. The principle function of the permanent baseplate safety cables is to prevent the towed vehicle from breaking loose in the event the connection between the frame of the towed vehicle and the baseplate fails or becomes disconnected. The cables must be connected from the baseplate to the frame rail or cross member of the vehicle's frame. The illustrations below show the possible arrangements recommended by Blue Ox®. Each permanent baseplate safety cable must have an adequate weight rating for the towing system. The weight rating of the two (2) cables together will not qualify.

Do not mount the permanent baseplate safety cables against wires, hoses or brake lines.

These permanent baseplate safety cables should remain installed as long as the baseplate is installed on the vehicle. Permanent baseplate safety cables are to be used in conjunction with, and NOT a replacement for legally required safety cables attaching the towed vehicle to the towing vehicle.

OPTION #1

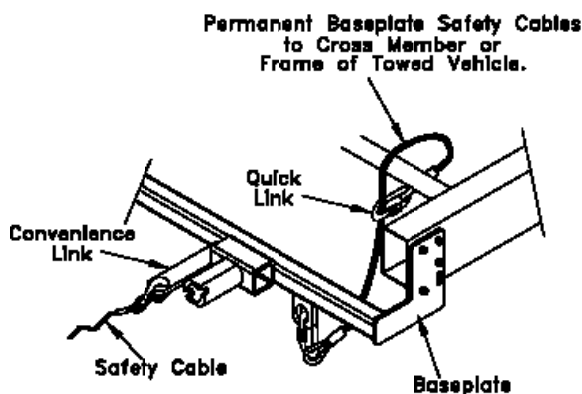

OPTION #2

