



Installation Instructions BX3218
Pontiac Grand Prix
Oldsmobile Intrigue

Serial No.

The front bumper molding, headlights and fog lights are removed for installation. Holes need to be drilled and the inner grill molding needs to be trimmed. DEALER OR INSTALLER: BE CERTAIN THE USER RECEIVES THE INSTRUCTION SHEET.

1. Open the hood and remove the headlights by removing the two plastic retaining clips from the top of each headlight. The retaining clips are rectangular white pieces set back from the top of the headlights. Remove the two push pins and middle Hex bolt from the top of the bumper fascia (top piece of fascia between the head lights).
2. Remove the Phillips head screws and push pins on the bottom of the bumper fascia. On the back side of the bumper fascia (directly in front of the front tires) are Phillips head screws (two on each side) that need to be removed. On the inside of the fascia is a 10mm Hex bolt connecting the bumper fascia and the fenders. Remove this bolt from each side of the vehicle. Pull the bumper fascia from the vehicle and set aside.



3. Once the bumper is off remove the plastic piece attached to the front of the metal bumper. This will ease the installation of the baseplate. Remove fog lights and set aside.

4. Notice the plastic air shroud surrounding the radiator. The front of the shroud forms to the bottom of the metal bumper. Pull down on this piece and locate the center hole on the bottom of the bumper. The center brace on the baseplate mounts to the bumper using the center hole. Let the plastic go and hold the baseplate up to the bottom of the plastic and metal bumper, marking the area which needs to be trimmed so the baseplate can be bolted to the bumper. After the plastic has been trimmed, insert the wire bolt plates into the frame from the back. Form the wire so the bolt can be placed in the center hole of the bumper. If the bolt does not fit through the hole, drill it out to 1/2". Hand tighten only.

5. Hold the appropriate side plates (see drawing on page 2) up to the main weldment. Notice that the plastic shroud needs to be trimmed on both sides of the baseplate to allow the side plates to be installed. Mark and trim the plastic. Once the plastic is trimmed bolt the side plates to baseplate. Each side plate is placed over the outside fog light bolt extending out of the bumper. Before tightening the side plates make sure they are up against the bottom of the bumper and the piece extending up is against the side of the metal below the frame.
6. Use the side plates as a template to drill holes in the frame and bumper (two 1/2" and one 3/8" holes on each side). Once the six holes are drilled remove the pieces from the vehicle. Bolt the side plates to the frame and bumper (main piece off the bumper). Use the hardware shown in the drawing on page 2.

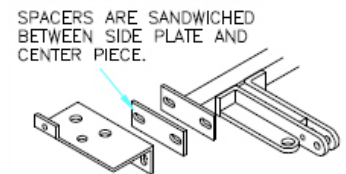

PASSENGER SIDE SHOWN

Figure 1

NOTE: Apply LOCTITE to all bolts.

7. Bolt the middle piece of the baseplate to the side plates and the bumper. On Pontiac Grand Prix insert the spacer on both sides to fill the gap between the side plates and the middle piece, if needed. **See Figure 1.** Once all bolts have been started and the baseplate is centered on the bumper, tighten and torque all bolts according to the chart in the General Instruction Sheet.
8. The triangular plates need to be bolted to the side of the frame (as shown in the diagram). Use the 3/8" hardware as shown in the diagram on page 2. The horn (passenger side) will have to be removed temporarily until the plate has been installed. Once that is done replace the horn. The 3/8" wire bolts can be inserted into the frame from either the bottom of the frame or its side. On the passenger side the wiper fluid reservoir can be unbolted from the frame to have access to the side opening. The triangular plates are installed to strengthen the connection between the frames and the metal bumper. **See Figure 2.**

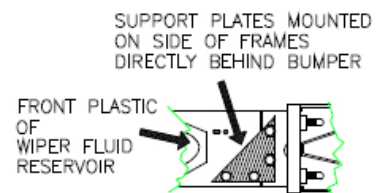

PASSENGER SIDE SHOWN

Figure 2

9. Replace the fog lights and connect wiring. Replace the plastic piece on the front of the bumper. NOTE: The one edge will touch the baseplate causing them to tilt slightly. Replace the bumper fascia and headlights. Connect headlight wiring.

Automatic

Tools Required

- 10mm Wrench
- 9/16" Wrench
- Loctite Blue or Red
- 3/4" Wrench
- Phillips Screw Driver
- 3/8" Drill Bit
- 1/2" Drill Bit
- Utility Knife
- Center Punch
- 7mm Wrench



Parts List

Ref. No.	Qty.	Part No.	Description
1	1	61-5442	Weldment, Baseplate BX3218
2	3	61-5459	1/2" Wire Bolt Plate
3	8	61-5285	3/8" Bolt with Wire
4	1	101-5978	Side Plate, Passenger Side, BX3218
*	1	101-5977	Side Plate, Drivers Side, BX3218 (not shown)
5	2	102-5893	Triangular Support, BX3218
6	2	201-0440	3/8-16 x 1 1/2 Hex Bolt, Grade 5
7	6	201-0011	1/2-13 x 1 1/4 Hex Bolt, Grade 5
8	10	202-0003	3/8-16 Hex Nut, Grade 5
9	9	202-0005	1/2-13 Hex Nut, Grade 5
10	10	203-0010	3/8" Lock Washer
11	9	203-0012	1/2" Lock Washer
12	9	203-0005	1/2" Flat Washer
13	2	201-0979	#12-14 x 1" Self Drilling Screw, ZP
14	2	101-5822	Adapter, 4 Way Connector
15	2	202-0047	#10-32 Hex Nut
16	2	203-0054	#10 Lock Washer
17	2	201-0192	#10-32 x 1/2" Slotted Round Head Screw
*	2	102-5888	Spacer Plate, BX3218 (shown Figure 1, Page 1)

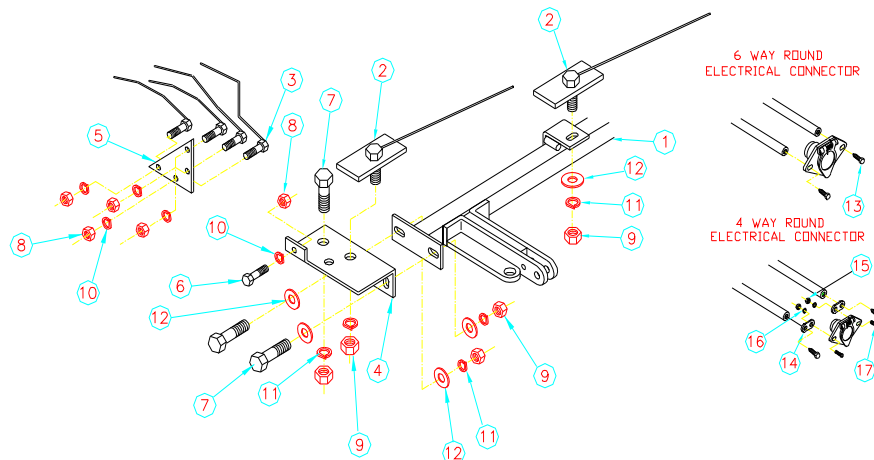

General Information

1. Ensure that your product(s) are registered online at www.blueox.com. It is crucial to register your product(s) so that you may be alerted of product offerings, updates, upgrades, maintenance and safety bulletins, and/or recalls.
2. **It is the owner's responsibility to inspect all towing equipment for cracked welds, missing or worn parts and loose bolts before each towing trip.** Be sure to use Loctite® Red on all bolts and tighten to the recommended specifications.
3. **It is the owner's responsibility to hook up all towing equipment per manufacturer's instructions/recommendations.**
4. Remove the attachment tabs when not in use (if applicable).

Notice To Baseplate Installer

1. It is YOUR responsibility to watch for:

- Oil cooler and air conditioner lines
- Electrical wires and hoses
- Missing parts or attaching points on the frame

** If the baseplate is improperly installed and is against a wire or hose, it could cause fluid leaks or electrical shorts some time after the actual baseplate installation.

Permanent Baseplate Safety Cable Installation

Permanent baseplate safety cables are strongly recommended when towing a vehicle with a tow bar. The principle function of the permanent baseplate safety cables is to prevent the towed vehicle from breaking loose in the event the connection between the frame of the towed vehicle and the baseplate fails or becomes disconnected. The cables must be connected from the baseplate to the frame rail or cross member of the vehicle's frame. The illustrations below show the possible arrangements recommended by Blue Ox®. Each permanent baseplate safety cable must have an adequate weight rating for the towing system. The weight rating of the two (2) cables together will not qualify.

Do not mount the permanent baseplate safety cables against wires, hoses or brake lines.

These permanent baseplate safety cables should remain installed as long as the baseplate is installed on the vehicle. Permanent baseplate safety cables are to be used in conjunction with, and NOT a replacement for legally required safety cables attaching the towed vehicle to the towing vehicle.

OPTION #1

Permanent Baseplate Safety Cables to Cross Member or Frame of Towed Vehicle.



OPTION #2

Permanent Baseplate Safety Cables to Cross Member or Frame of Towed Vehicle.

