

Please read **BOTH** these Installation Instructions and the General Instructions before attempting to install or operate this equipment.

- Blue Ox® towing products and accessories are intended to be installed by Blue Ox® Dealers who are familiar with our products and have the equipment necessary and knowledge to do "fit work". When necessary Blue Ox® Dealers can be found at www.blueox.com or by contacting our Customer Care Department at (402) 385-3051.
- Many Blue Ox® Baseplates are designed to use existing holes and hardware to mount the baseplate to the towed vehicle. Even though bolts are there, do not assume they are adequate for baseplate mounting. Always use hardware supplied in the hardware kit and existing hardware specified in the Baseplate Installation Instructions.

Attachment Tab Height: 14.5"

Attachment Tab Width: 18"

Bolt Torque Specifications

Torque in Foot-Pounds for Metric Bolts

Bolt Size	Grade 8.8	Grade 10.9
6MM	6	8
8MM	16	22
10MM	31	40
12MM	54	70
14MM	89	117

Confirm the towability and pre-towing procedures for your vehicle with the owner's manual or contact the vehicle's manufacturer for specific towing procedures.

Bolt Torque Specifications

Torque in Foot-Pounds for Inch Bolts

Bolt Size	Grade 5	Grade 8
1/4"	10	14
5/16"	19	29
3/8"	33	47
7/16"	54	78
1/2"	78	119
5/8"	154	230



If the front of your vehicle looks different than this, call us at (402) 385-3051.

! WARNING

Failure to read and follow these instructions could result in separation of the towed vehicle from the tow bar, causing property damage, loss of towed vehicle, personal injury or death.

BX2710

2005-08 Kia Sportage

Installation Instructions

Parts List

Ref. No.	Qty.	Part #	Description
1	1	61-6172	Weldment, Baseplate, BX2710
2	6	61-5208	Weldment, 3/8-16 Nut Plate, w/ 14" Wire
3	6	201-0440	3/8-16 x 1 1/2" Hex Bolt, Grd. 5, ZP
4	6	203-0010	3/8" Lock Washer, ZP
5	2	201-0979	#12-14 x 1" Self Drilling Screw, ZP
6	2	201-0192	#10-32 x 1/2" Slot Rd. Hd. Screw
7	2	203-0054	#10 Lock Washer
8	2	202-0047	#10-32 Hex Nut
9	2	101-5822	Adapter, 4 Way Connector
10	2	62-3468	Attachment, Assembly, SF/SB (R)
11	4	203-0001	1/4" Flat Washer, ZP (Not Shown)
12	2	290-0437	Cap Plug (Not Shown)

Tools Required

8MM Socket	Phillips Screw Driver
10MM Socket	13/32" Socket
Utility Knife	Reciprocating Saw
12MM Socket	9/16" Socket
Loctite® RED	Vise Grip

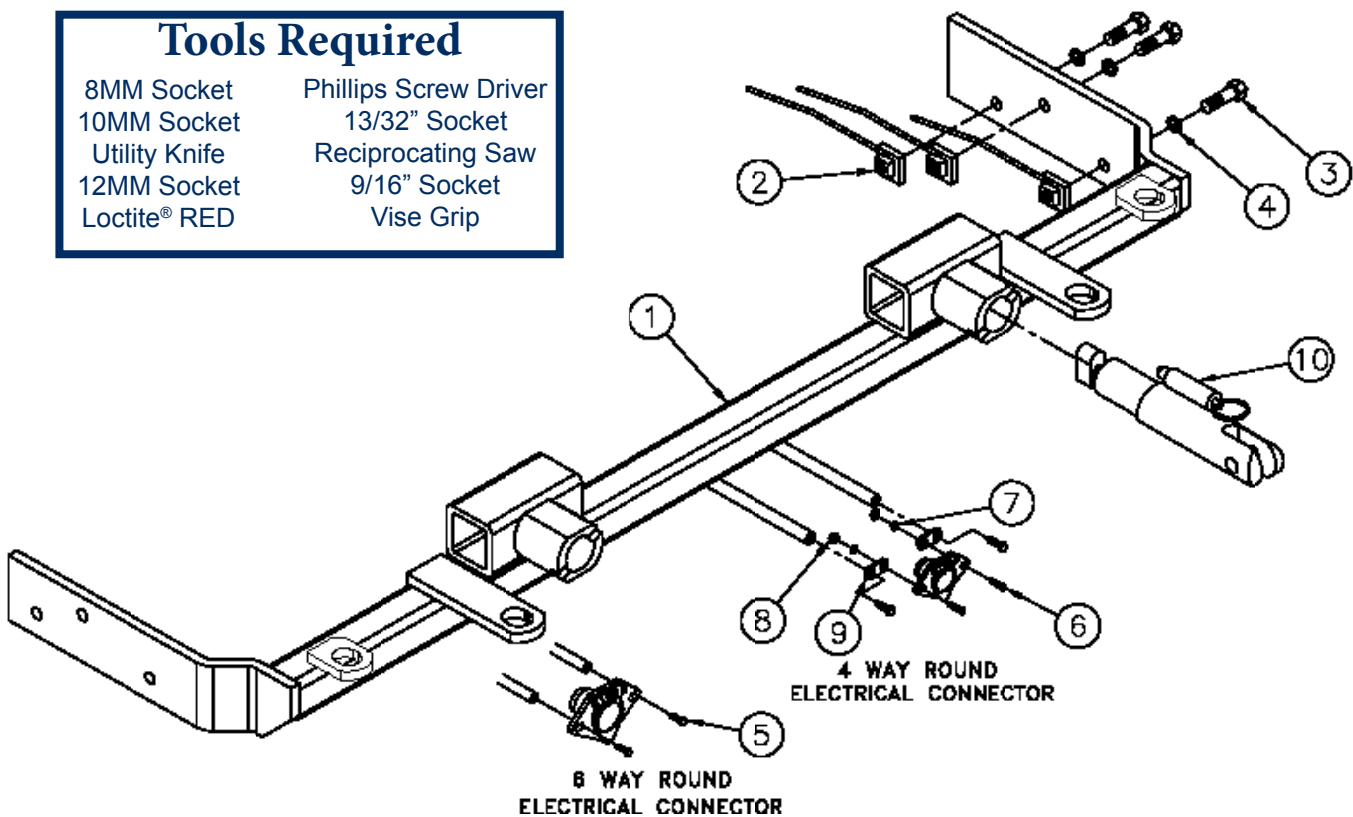

Important:

Use only genuine factory replacement parts on your baseplate. Do **NOT** substitute homemade or non-typical parts. If a bolt is lost or in need of replacement, for your safety and the preservation of your baseplate, be sure to use a replacement bolt of the same grade (In most cases it will be Grade 5, please reference the parts list above). Replacement parts may be ordered through your nearest Blue Ox® Dealer or Distributor, or call our Customer Care Team at (402)385-3051. Failing to follow and/or altering these installation instructions in either installation or required equipment will void the manufacturer's warranty.

BX2710 2005-08 Kia Sportage Installation Instructions

Attachment Tabs:

Motorhome mount tow bars are recommended for use with this baseplate. Due to the design of the removable tabs, the RangeFinder II and Ambassador tow bars can not be used. Adapters, except the BX8833 and BX88151, can not be used with this baseplate.

Instructions:

The front fascia, windshield washer reservoir, and the belly pan are removed and reinstalled.

Trimming of the frame horn bracket, radiator support, air dam and front fascia grille styles is required.

The dimensional variations between otherwise identical vehicles can be considerable. While the baseplate was designed for easy installation, it may be necessary to tailor the baseplate slightly to compensate for auto manufacturer's tolerances. These minor adjustments may include filing a hole slightly, bending electrical rods or bending end plates.

The Bx8869 Bulb and Socket Wiring Kit is recommended for this vehicle.



Installation Instructions:



1. Remove 12 Phillips push pins from the top of the fascia. Then, remove the black plastic from the top of the fascia. Set push pins aside to be reinstalled later.



2. Using the 10MM socket remove two metric bolts from top corners of the fascia, see the white arrows in the photo above. Remove one Phillips screw from the top of the fascia, see grey arrow in the photo above. Set all aside to be reinstalled later.

Handling of some cosmetic parts when installing this product may require the use of protective covers, rags, specialty tools, etc. to prevent damage.

BX2710
2005-08 Kia Sportage
Installation Instructions



3. Just inside the wheel well, on the edge of the fascia, remove one metric bolt with an 8MM socket. Do this to both sides of the vehicle. Set bolts aside to be reinstalled later.



4. Just forward of the front tire, remove one Phillips push pin. Do this to both sides of the vehicle. Set aside to be reinstalled later.

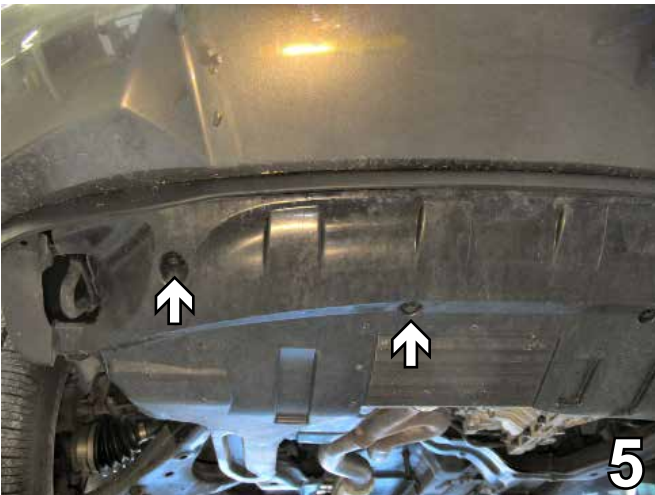

5. Using a 12MM socket, remove four metric bolts from the belly pan. Do this to both sides of the vehicle, the passenger's side is shown. Set belly pan and bolts aside to be reinstalled later.



6. Remove five push pins from the bottom of the fascia, the driver's side is shown. Set push pins aside to be reinstalled later.

BX2710

2005-08 Kia Sportage

Installation Instructions

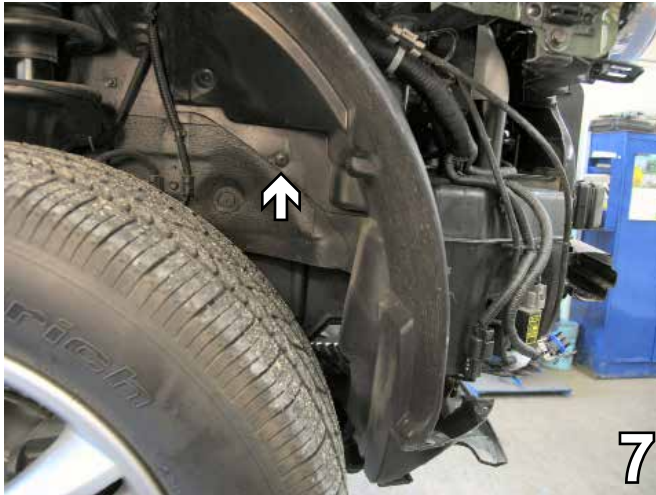

7. Remove one Phillips push pin from the wheel well cover. Do this to both sides of the vehicle. Set push pins aside to be reinstalled later.

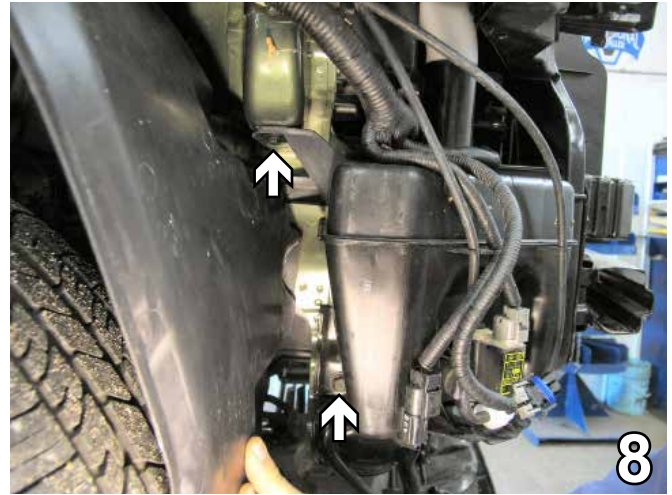

8. Press the wheel well cover toward the tire to expose two metric bolts to be removed using the 10MM socket. Unplug electrical connections, disconnect and plug water lines. Set bolts aside to be reinstalled later.



9. Using a 10MM socket, remove one metric bolt from the top spout of the windshield washer reservoir. Guide the windshield washer down and remove from the vehicle set aside to reinstall later. Set bolts and washer reservoir aside to be reinstalled later.

NOTE: If the vehicle has an air intake baffle, a 12MM socket should be used to remove the two bolts from the front side and one from the back. Set the baffle and the bolts aside to be reinstalled after the baseplate has been installed.



10. Using the reciprocating saw, trim away frame horn end by cutting vertically just forward of the bracket's rear bolt hole and horizontally along the entire width of the frame horn end and repeating to complete the rectangle. Do this on both sides of the vehicle, the driver's side is shown.

BX2710
2005-08 Kia Sportage
Installation Instructions

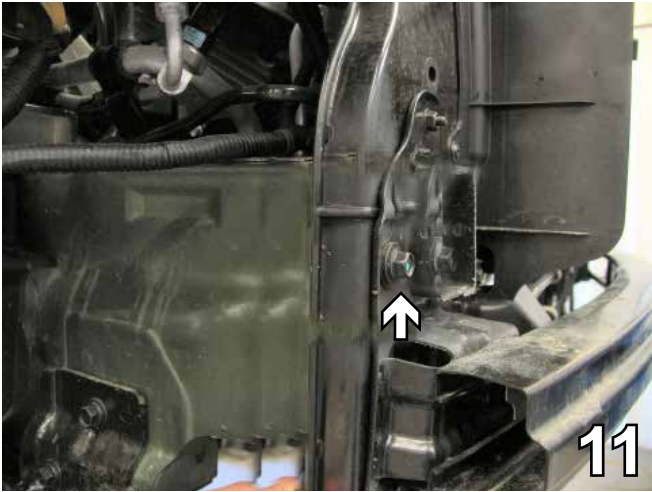

11. Using the 12MM socket remove one metric bolt from frame. Do this to both sides of the vehicle. Set bolts aside to be reinstalled later.



12. On the passenger's side radiator support, mark and trim a section 3 1/4" high and flush with the frame rail to open the area for baseplate installation.



13. On the driver's side radiator support, mark and trim a section 3 1/2" high and flush with the frame rail to open the area for baseplate installation.



14. Using a utility knife, mark and trim the air dam 3 1/2" up from the metal bumper and horizontally 2 5/8". Do this to both sides of the vehicle, the driver's side is shown.

BX2710

2005-08 Kia Sportage

Installation Instructions



15. Remove the rubber grommet from the frame rail. Do this to both sides of the vehicle, the driver's side is shown.



16. On the back side of the fascia, locate the openings closest to the grille edge. On the middle opening, cut in 1/2" and down, angling the cut so that it continues to the opposite edge of the opening. On the lower far left opening, cut in 1/2" and then upward, angling to the opposite edge also. Do this to both sides of the vehicle.



17. On upper opening, second from the grille edge, remove the horizontal grille style using the utility knife.



18. Slide the baseplate onto the frame through the opening in the radiator support (see steps 12 & 13). Clamp into place using the large vise grips. Using the baseplate as a template, drill three holes in the frame with the 13/32" drill bit. Do this to both sides of the vehicle, the driver's side is shown.

When using power drills be aware of the dangers of torque and drill bit length.

Baseplate is painted white for illustrative purposes ONLY.

The actual baseplate has a black Powder coat finish.

BX2710

2005-08 Kia Sportage

Installation Instructions



19. Insert three 3/8-16 nut plates through the lower bumper opening and align with drilled holes in the baseplate end plates. Insert the three 3/8-16 x 1 1/2" hex bolts and 3/8" lock washers and fasten to the nut plates. Do this to both sides of the vehicle, the driver's side is shown.



20. Reconnect electrical and water lines to windshield washer reservoir.

****BE SURE TO USE LOCTITE® RED ON ALL BOLTS BEFORE TIGHTENING. TIGHTEN ALL BOLTS ACCORDING TO THE TORQUE CHART ON PAGE 1 OF THESE INSTRUCTIONS OR ON PAGE 3 OF THE BASEPLATE TOWING GENERAL INSTRUCTIONS.**



21. Remove one push pin between windshield washer reservoir and metal bumper (see 21-A). Insert four flat washers for additional clearance (see 21-B) and reinstall windshield washer reservoir to its original position.



22. Reinstall the belly pan, see Step 5.

Be sure that ALL electrical connections are plugged in properly and functioning BEFORE installing the fascia.

23. Reinstall fascia, inserting all screws, push pins, and bolts.

24. Install the tow bar and safety cables according to the instructions provided in their packages. When demonstrating this to the customer, be sure to include all contents of their Blue Ox packages.

BX2710 2005-08 Kia Sportage Installation Instructions

DEALER or INSTALLER:

Be certain the user receives the instruction sheets for their products.

CUSTOMER SERVICE COMMITMENT



Without removable tabs installed.

Blue Ox is committed to providing you with exceptional customer care throughout your lifetime with our products. Our team is here to assist you with any questions you may have regarding the performance of your product. Simply call 1-402-385-3051 and you can speak with our customer care team.

Additionally, please visit our website to see which rallies our Destination America team will be attending. For a nominal fee, our service technician will service your towing system to ensure it's in proper working condition. Also as a commitment to our customers, should you visit our factory you can stay at our full service Blue Ox campground at no charge along with enjoying a factory tour.



With removable tabs installed.

Again thank you for being our customer and for the confidence you have shown in the performance of our products. It is because of customers like you we enjoy the success we have today.

If the baseplate is in an accident, it must be replaced. DO NOT use it again! An accident can cause unseen damage and using it again could result in more damage or serious injury. DO NOT use the baseplate if it is damaged or missing parts.



© 2005, 07, 08, 09, 11 Blue Ox
One Mill Road, Industrial Park
Pender, Nebraska 68047
Phone: (402) 385-3051
Toll Free: (888) 425-5382
Fax: (402) 385-3360
www.blueox.com

General Information

1. Ensure that your product(s) are registered online at www.blueox.com. It is crucial to register your product(s) so that you may be alerted of product offerings, updates, upgrades, maintenance and safety bulletins, and/or recalls.
2. **It is the owner's responsibility to inspect all towing equipment for cracked welds, missing or worn parts and loose bolts before each towing trip.** Be sure to use Loctite® Red on all bolts and tighten to the recommended specifications.
3. **It is the owner's responsibility to hook up all towing equipment per manufacturer's instructions/recommendations.**
4. Remove the attachment tabs when not in use (if applicable).

Notice To Baseplate Installer

1. It is YOUR responsibility to watch for:

- Oil cooler and air conditioner lines
- Electrical wires and hoses
- Missing parts or attaching points on the frame

** If the baseplate is improperly installed and is against a wire or hose, it could cause fluid leaks or electrical shorts some time after the actual baseplate installation.

Permanent Baseplate Safety Cable Installation

Permanent baseplate safety cables are strongly recommended when towing a vehicle with a tow bar. The principle function of the permanent baseplate safety cables is to prevent the towed vehicle from breaking loose in the event the connection between the frame of the towed vehicle and the baseplate fails or becomes disconnected. The cables must be connected from the baseplate to the frame rail or cross member of the vehicle's frame. The illustrations below show the possible arrangements recommended by Blue Ox®. Each permanent baseplate safety cable must have an adequate weight rating for the towing system. The weight rating of the two (2) cables together will not qualify.

Do not mount the permanent baseplate safety cables against wires, hoses or brake lines.

These permanent baseplate safety cables should remain installed as long as the baseplate is installed on the vehicle. Permanent baseplate safety cables are to be used in conjunction with, and NOT a replacement for legally required safety cables attaching the towed vehicle to the towing vehicle.

OPTION #1

Permanent Baseplate Safety Cables to Cross Member or Frame of Towed Vehicle.

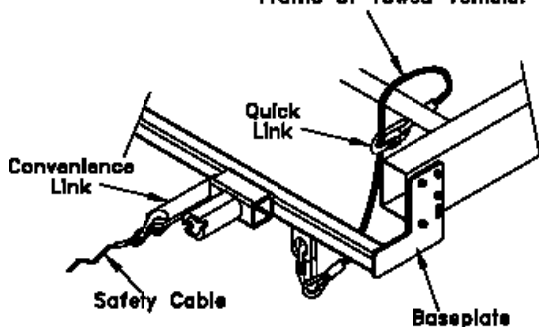

OPTION #2

Permanent Baseplate Safety Cables to Cross Member or Frame of Towed Vehicle.

