



BLUE OX®

Baseplate Installation Instructions

BX2620 2010 Ford F550

Commercial Application Only Installation Instructions

Serial Number

Please read BOTH these Installation Instructions and the General Towing Instructions before attempting to install or operate this equipment.

1. Blue Ox® towing products and accessories are intended to be installed by Blue Ox® Dealers who are familiar with our products and have the equipment and knowledge to do “fit work.” When necessary, Blue Ox® Dealers can be found at www.blueox.com or by contacting our Customer Care Department at (402) 385-3051.

Attachment Tab Height: 22 1/2”
Attachment Tab Width: 31 7/8”

2. Many Blue Ox® Baseplates are designed to use existing holes and hardware to mount the baseplate to the towed vehicle. Even though bolts are there, do not assume they are adequate for baseplate mounting. Always use hardware supplied in the hardware kit or existing hardware specified in the Baseplate Towing Installation Instructions.

Bolt Torque Specifications
Torque in Foot-Pounds for Metric Bolts

Bolt Size	Grade 8.8	Grade 10.9
6MM	6	8
8MM	16	22
10MM	31	40
12MM	54	70
14MM	89	117

Confirm the towability and pre-towing procedures for your vehicle with the owner’s manual or contact the vehicle’s manufacturer for specific towing procedures.

Bolt Torque Specifications
Torque in Foot-Pounds for Inch Bolts

Bolt Size	Grade 5	Grade 8
1/4”	10	14
5/16”	19	29
3/8”	33	47
7/16”	54	78
1/2”	78	119
5/8”	154	230



If the front of your vehicle looks different than this, call us at (402) 385-3051.

! WARNING
Failure to read and follow these instructions could result in separation of the towed vehicle from the tow bar, causing property damage, loss of towed vehicle, personal injury or death.

BX2620

2010 Ford F550 Commercial Application Only

Installation Instructions

Parts List

Ref. No.	Qty.	Part #	Description
1	1	61-6749	WLDM'T, BP, DS, BX2620
2	1	61-6750	WLDM'T, BP, PS, BX2620
3	6	201-0369	1/2-13 X 3 1/2 HEX BOLT,GRD.5, ZP
4	12	203-0005	1/2 FLAT WASHER, ZP
5	6	203-0012	1/2 LOCK WASHER, ZP
6	6	202-0016	1/2-13 HEX CENT. DIMP. LOCK NUT, ZP
7	8	201-0351	5/8-11 X 2 HEX BOLT, GRD 5, ZP.
8	4	203-0006	5/8 FLAT WASHER, ZP
9	8	203-0013	5/8 LOCK WASHER, ZP
10	8	202-0008	5/8-11 HEX NUT, GRD. 8, ZP
11	1	101-6739	BRACKET, ELECTRICAL, BX2908
12	4	201-0050	1/4-20 X 3/4 HEX BOLT GRD.5, ZP
13	2	203-0001	1/4 FLAT WASHER, ZP
14	2	203-0008	1/4 LOCK WASHER, ZP
15	4	202-0069	1/4-20 HEX FLANGE WHIZ LOCK NUT, ZP
16	2	201-0192	10-32 X 1/2 SLOT, RD. HD. SCREW
17	2	203-0054	#10 LOCK WASHER
18	2	202-0047	#10-32 HEX NUT
19	2	101-5822	ADAPTER, 4 WAY CONNECTOR
	2	226-0049	BASEPLATE SAFETY CABLE, 36" CL IV (Not Shown)
	2	229-0512	QUICKLINK, 1/2, ZP (Not Shown)

Tools Required

13MM Socket	Large Vise Grips	Tape Measure
15MM Socket	Drill	21/32" Drill Bit
18MM Socket	Flat Screwdriver	5/16" Drill Bit
3/4" Socket/Wrench	Torque Wrench	17/32" Drill Bit
	Loctite® RED	

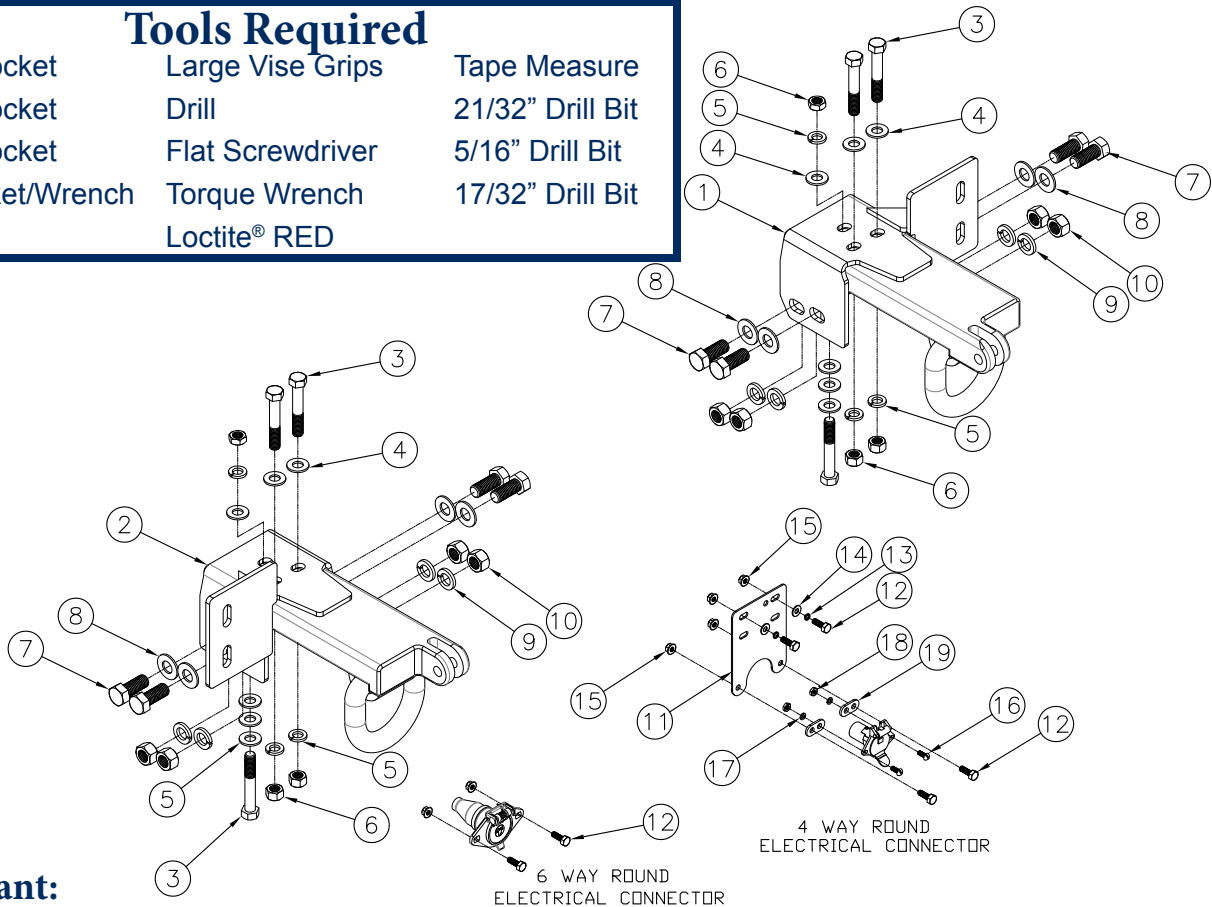

Important:

Use only genuine factory replacement parts on your baseplate. Do **NOT** substitute homemade or non-typical parts. If a bolt is lost or in need of replacement, for your safety and the preservation of your baseplate, be sure to use a replacement bolt of the same grade (In most cases it will be Grade 5, please reference the parts list above). Replacement parts may be ordered through your nearest Blue Ox® Dealer or Distributor. Failing to follow and/or altering these installation instructions in either installation or required equipment will void the manufacturer's warranty. Towing behind a non-motorized vehicle will void the warranty.

BX2620
2010 Ford F550
Commercial Application Only
Installation Instructions

Vehicle Weight:

Due to the weight of this vehicle, use of the BX7520P towbar is required. This baseplate will not work with standard Blue Ox towbar lugs or adapters due to the design of the attachment tabs. Also, you must insure your hitch rating is adequate for towing this vehicle.

Installation Notes: The fascia and air dam are removed for installation. Some drilling is required. Tow hooks must be removed and remain off the vehicle after installation.

The dimensional variations between otherwise identical vehicles can be considerable. While the baseplate was designed for easy installation, it may be necessary to tailor the baseplate slightly to compensate for auto manufacturer's tolerances. These minor adjustments may include filing a hole slightly, bending electrical rods or bending end plates.

The BX8848 4-Diode Wiring Kit is recommended for this vehicle.

Handling of some cosmetic parts when installing this product may require the use of protective covers, rags, specialty tools, etc. to prevent damage.

Installation Instructions:



1. Using a 13MM socket, remove two metric bolts located just forward of the front tire. Do this to both sides of the vehicle. Set bolts aside to be reinstalled later.



2. Remove three push pins from the bottom edge of the plastic cover. Set cover and push pins aside to be reinstalled later.

BX2620
2010 Ford F550
Commercial Application Only
Installation Instructions

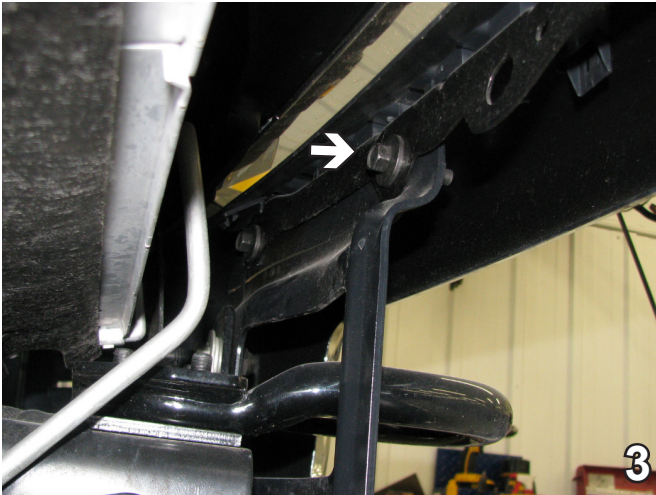

3. Remove the bolt which is exposed after removal of the cover. Set the bolt aside to be reinstalled later.

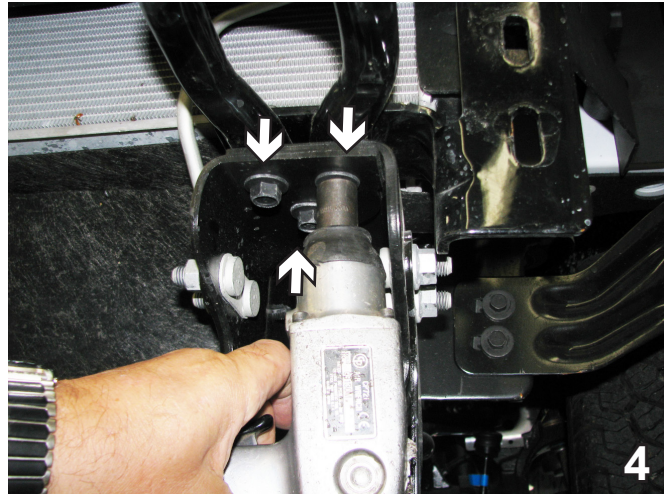

4. Remove the tow hook by removing the three bolts underneath it using a 15MM socket. Set tow hooks and bolts aside--they will not be used again. Use a 17/32" drill bit to ream the two front holes. Do this on both sides.

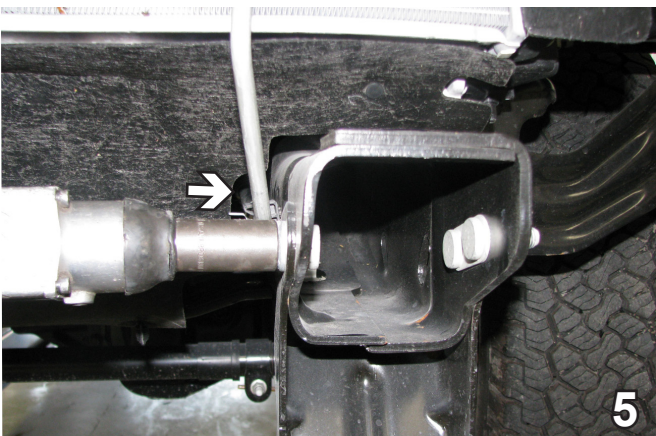

5. On the driver's side, it will be necessary to pull the Christmas tree pin from the coolant line bracket that goes into the frame in order to position the baseplate. It will be reinstalled later.

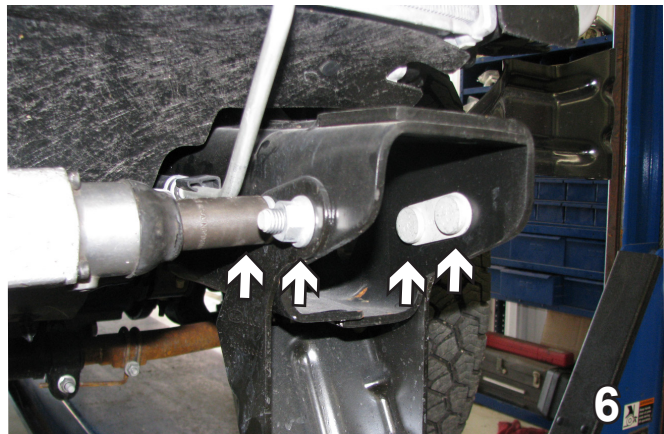

6. Using an 18MM socket, remove the two bolts on each side of the bumper support. Do this on both sides of the vehicle. Set bolts and support aside to be reinstalled later.



7. On the back of the bumper passenger side, some vehicles have a heater core element plug. If so, the Christmas tree pin will need to be released. Also remove the extension from the end of the frame rail.

8. On the passenger side back bottom lower radiator, remove the push pin from rubber air dam. Set the pin and the air dam aside to be reinstalled later.

BX2620
2010 Ford F550
Commercial Application Only
Installation Instructions

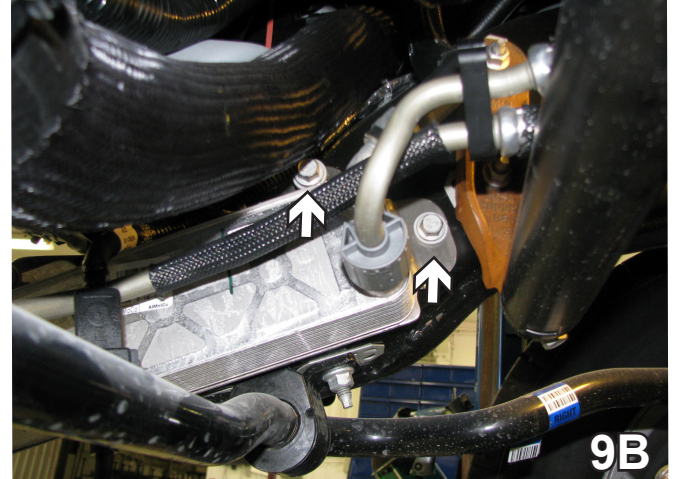
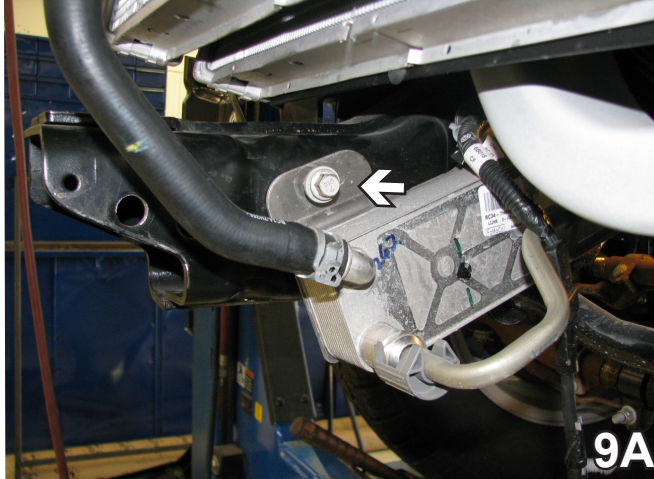

9. Using a 13MM socket remove the three metric bolts from the coolant transfer box on the passenger side. Then pull the box out of the way so that the side holes can be drilled using the baseplate as a template.

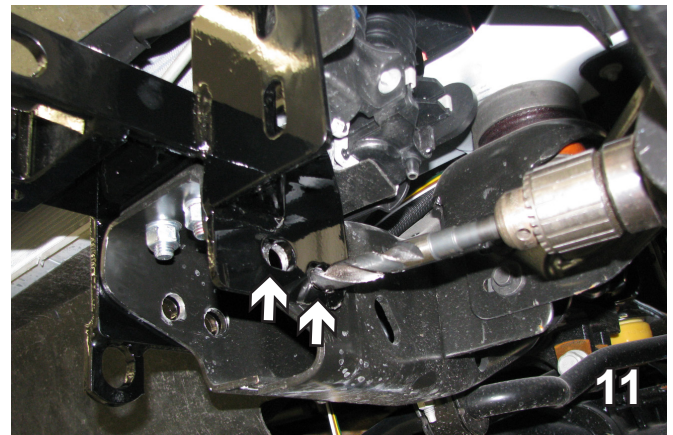
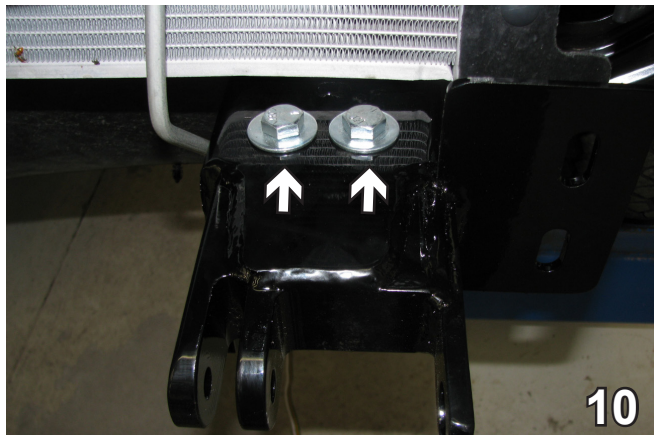

10. Slide the baseplate over the frame rail. Align with the top holes. Insert 1/2-13 x 3 1/2" hex bolts with 1/2" flat washer on the top. Attached to 1/2" lock washers and 1/2-13 hex nuts. Do this on both sides. Tighten with Loctite Red.

11. Align the baseplate with the existing holes in the frame. With the baseplate as a template, use a 17/32" drill bit to ream out the holes on both sides of the frame rail if needed. Do this on both sides of the vehicle.

BE SURE TO USE LOCTITE® RED ON ALL BOLTS BEFORE TIGHTENING. TIGHTEN ALL BOLTS ACCORDING TO THE TORQUE CHART ON THE FRONT PAGE OF THESE INSTRUCTIONS OR ON PAGE 3 OF THE BASEPLATE TOWING GENERAL INSTRUCTIONS.

When using power drills be aware of the dangers of torque and drill bit length.

BX2620
2010 Ford F550
Commercial Application Only
Installation Instructions

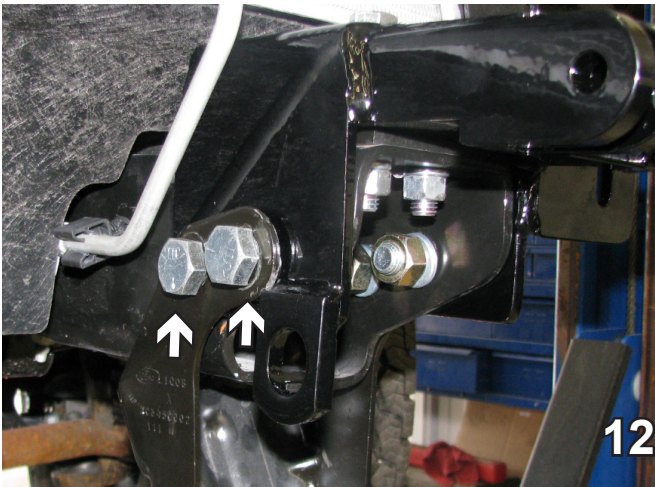

12. Slide the lower support bumper brace back over. It may need to be widened a bit. Loosely install all four 5/8-11 x 2" bolts with 5/8 flat washers attached to 5/8" lock washers and 5/8-11 hex nuts on the inside. Then use Loctite Red and tighten. Do this on both sides.

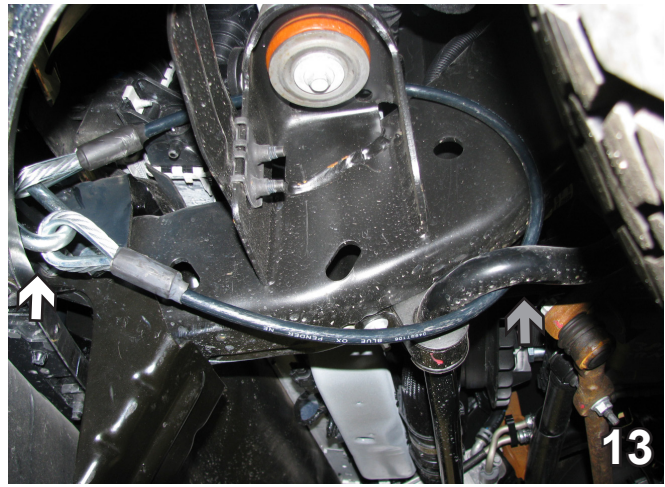

13. Attach the permanent baseplate safety cables to the provided convenience link on the baseplate. The photo above shows the recommended installation of the cables to frame of vehicle (see white arrow). Additional options may interfere with suggested mounting; in this case secure the cables to a solid piece of the frame as described in the instructions included with the permanent baseplate safety cables. Be sure the safety cables do not rub against any hoses or moving parts. Do this to both sides of the vehicle.

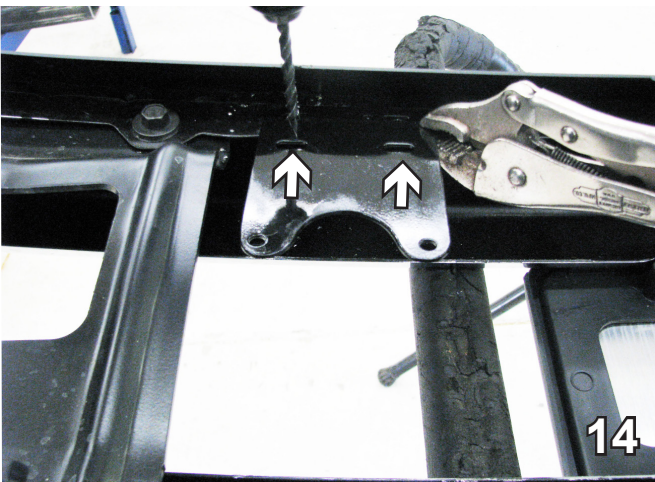

14. Place the metal bumper face down. Position the electrical bracket over the two existing holes on the inside top driver's side. Drill out the hole on the left using a 5/16" drill bit.

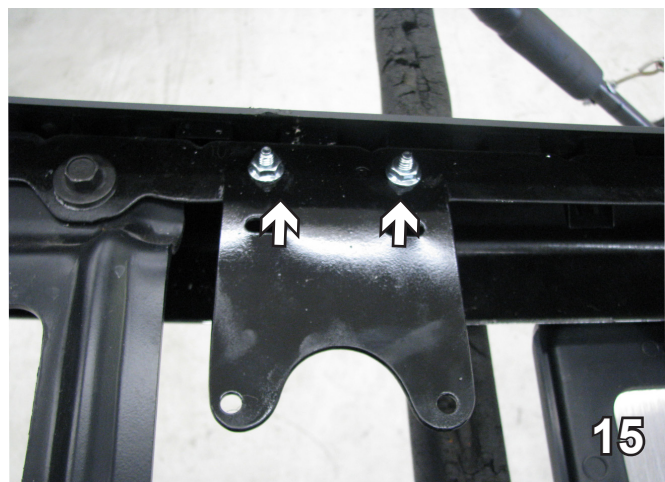

15. Install 1/4-20 x 3/4" bolts with 1/4" flat washers, 1/4 lock washers and 1/4-20 whiz nuts.

Be sure that **ALL** electrical connections are plugged in properly and functioning **BEFORE** installing the fascia.

16. Reinstall bumper, bolts and reconnect wiring. The installation of the baseplate is complete.

BX2620
2010 Ford F550
Commercial Application Only
Installation Instructions

Install the tow bar and safety cables according to the instructions provided in their packages. When demonstrating this to the customer, be sure to give all the contents and packages to the consumer.

Do **NOT** substitute other devices if the tow bar pins and clips are misplaced.

DEALER or INSTALLER:
Be certain the user receives the instruction sheets for their products.

CUSTOMER SERVICE COMMITMENT

Blue Ox is committed to providing you with exceptional customer care throughout your lifetime with our products. Our team is here to assist you with any questions you may have regarding the performance of your product. Simply call (402) 385-3051 and you can speak with our customer care team.

Additionally, please visit our website to see which rallies our Destination America team will be attending. For a nominal fee, our service technician will service your towing system to ensure it's in proper working condition. Also as a commitment to our customers, should you visit our factory you can stay at our full service Blue Ox campground at no charge along with enjoying a factory tour.

Again thank you for being our customer and for the confidence you have shown in the performance of our products. It is because of customers like you we enjoy the success we have today.

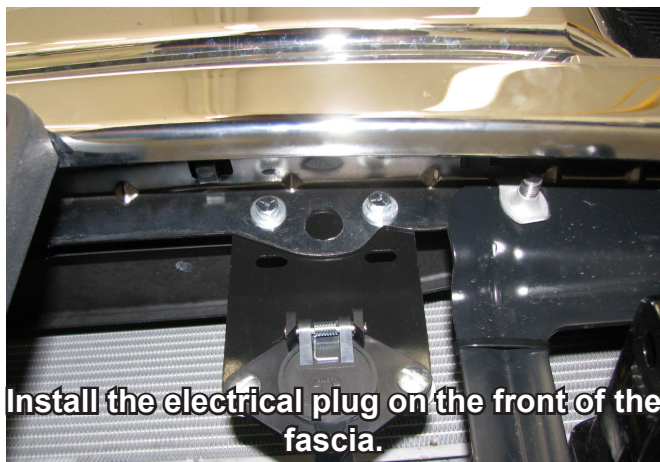

If the baseplate is in an accident, it must be replaced. DO NOT use it again! An accident can cause unseen damage and using it again could result in more damage or serious injury. DO NOT use the baseplate if it is damaged or missing parts.



© 2010 Blue Ox
One Mill Road, Industrial Park
Pender, Nebraska 68047
Phone: (402) 385-3051 • Fax: (402) 385-3360
www.blueox.com

BLUE OX ORIGINAL PURCHASERS THREE YEAR LIMITED WARRANTY

Automatic Equipment Manufacturing Company ("Automatic") warrants to the original (first) retail purchaser that this product, manufactured by Automatic, shall be free from defect in material and workmanship under normal use and service for a period of three years from the date of delivery.

During said three-year period, Automatic will repair or replace any parts that have been returned by the original purchaser, to the factory, transportation prepaid, and in Automatic's sole and absolute opinion found to be defective.

Limitations on Warranty Coverage:

Coverage under this warranty will be valid only if the customer warranty card is returned by the original purchaser within 30 days of purchase.

Coverage under this warranty will be effective only when a copy of the original invoice, showing date and place of purchase, accompanies any claim for warranty. This warranty is NON TRANSFERABLE.

This limited warranty will not cover, in any way or form, any alleged damages caused by incorrect or improper installation, improper use, modification or neglect of product, failure to properly service and maintain, misuse, act of God, accident or failure of the user to follow guidelines contained in the instructional material provided by Automatic.

This warranty does not cover normal wear and tear, paint or rust.

Warrantor assumes no responsibility to the owner for loss of use of product, loss of time, inconvenience or any other damage consequential or otherwise. Including, but not limited to mileage, expense of transporting of product, return shipping expense, mechanics travel time, telephone, road service, towing, and rental during repairs, travel, lodging, loss or damage to personal property or loss of earnings.

REPAIR OR REPLACEMENT AS SET FORTH IN THIS LIMITED WARRANTY IS THE SOLE EXCLUSIVE REMEDY OF THE PURCHASER. AUTOMATIC SHALL NOT BE LIABLE FOR ANY INCIDENTAL OR CONSEQUENTIAL DAMAGES FOR BREACH OF ANY EXPRESS OR IMPLIED WARRANTY ON THIS PRODUCT. EXCEPT TO THE EXTENT PROHIBITED BY APPLICABLE LAW, ANY IMPLIED WARRANTY OF MERCHANTABILITY OR FITNESS FOR A PARTICULAR PURPOSE ON THIS PRODUCT IS LIMITED IN LENGTH TO THE DURATION OF THIS WARRANTY.

Please visit <http://blueox.com/warranty/> to register your warranty

