



Baseplate Installation Instructions

BX2618

2008-16 Ford F250
(Includes Super Duty)
Installation Instructions

Attachment Tab Height: 23 1/2"

Attachment Tab Width: 34 1/2"

Serial Number

Please read BOTH these Installation Instructions and the General Instructions prior to installing or operating this equipment.

- Blue Ox® towing products and accessories are intended to be installed by Blue Ox® Dealers who are familiar with our products and have the equipment and knowledge necessary to do "fit work". If needed, Blue Ox® Dealers can be found at www.blueox.com or by contacting our Customer Care Department at (402) 385-3051.
- Many Blue Ox® baseplates are designed to use existing holes and hardware to mount the baseplate to the towed vehicle. Even though bolts are there, do not assume they are adequate for baseplate mounting. Always use the hardware supplied in the hardware kit and existing hardware as specified in the installation instructions.

Bolt Torque Specifications

Torque in Foot-Pounds for Inch Bolts

Bolt Size	Grade 5	Grade 8
1/4"	10	14
5/16"	19	29
3/8"	33	47
7/16"	54	78
1/2"	78	119
5/8"	154	230
3/4"	257	380



If the front of your vehicle looks different than this, please contact us at (402)385-3051.

Reference your vehicle owner's manual for manufacturer's towing specifications.

Bolt Torque Specifications

Torque in Foot-Pounds for Metric Bolts

Bolt Size	Grade 8.8	Grade 10.9
6MM	6	8
8MM	16	22
10MM	31	40
12MM	54	70
14MM	89	117
16MM	161	230
18MM	222	318



WARNING

Failure to read and follow these instructions could result in separation of the towed vehicle from the tow bar, causing property damage, loss of towed vehicle, personal injury or death.

BX2618
2008-16 Ford F250
(Includes Super Duty)
Installation Instructions

Parts List

Ref. No.	Qty.	Part #	Description
1	1	61-6726	WLDM'T, BP, DS, BX2618
2	1	61-6727	WLDM'T, BP, PS, BX2618
3	1	101-6135	BRACKET ELECTRICAL, 90 DEGR.
4	12	201-0051	1/2-13 X 1 1/2 HEX BOLT GRD.5, ZP
5	12	203-0012	1/2 LOCK WASHER, ZP
6	12	202-0094	1/2-13 HEX NYL. INS. LOCK NUT, ZP
7	4	201-0050	1/4-20 X 3/4 HEX BOLT GRD.5, ZP
8	4	203-0008	1/4 LOCK WASHER, ZP
9	4	203-0001	1/4 FLAT WASHER, ZP
10	4	202-0069	1/4-20 HEX FLANGE WHIZ LOCK NUT, ZP
11	2	201-0192	10-32 X 1/2 SLOT, RD. HD. SCREW
12	2	203-0054	#10 LOCK WASHER
13	2	202-0047	#10-32 HEX NUT
14	2	101-5822	ADAPTER, 4 WAY CONNECTOR
15	2	62-3469	ATT TAB ASSY, REM, SF/LB, 1 HOLE
	2	226-0049	BASEPLATE SAFETY CABLE, 36" CL IV (Not Shown)
	2	229-0512	QUICKLINK, 1/2, ZP (Not Shown)
	2	290-0437	RECEIVER, CAP PLUG (BLK) (Not Shown)

Tools Required

15MM Socket
18MM Socket
3/4" Socket/ Wrench
Drill
17/32" Drill Bit
Loctite® RED

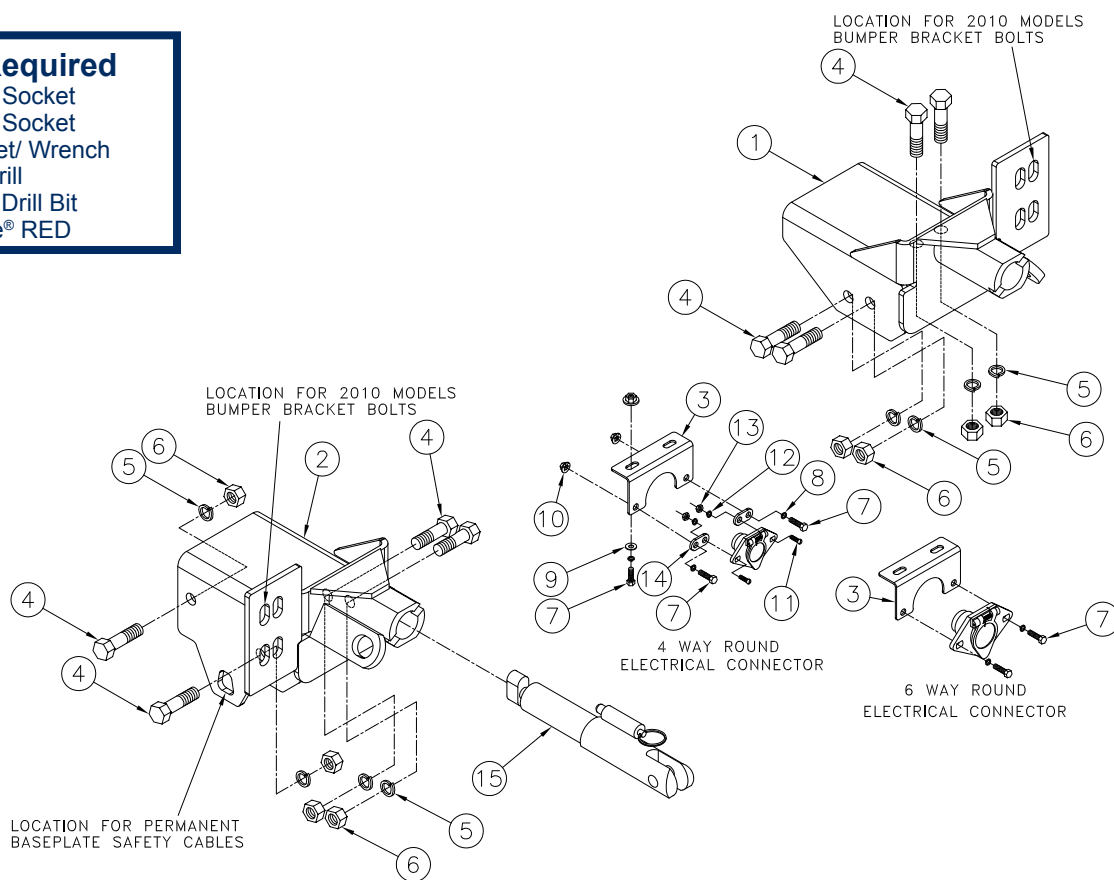

Important:

Use only genuine factory replacement parts on your baseplate. Do **NOT** substitute homemade or non-typical parts. If a bolt is lost or in need of replacement, for your safety and the preservation of your baseplate, be sure to use a replacement bolt of the same grade (In most cases it will be Grade 5, please reference the parts list above). Replacement parts may be ordered through your nearest Blue Ox® Dealer or Distributor. Failing to follow and/or altering these installation instructions in either installation or required equipment will void the manufacturer's warranty.

BX2618
2008-16 Ford F250
(Includes Super Duty)
Installation Instructions

Installation Notes: The fascia and air dam are removed for installation. Some drilling is required. Tow hooks must be removed and remain off the vehicle after installation.

The dimensional variations between otherwise identical vehicles can be considerable. While the baseplate was designed for easy installation, it may be necessary to tailor the baseplate slightly to compensate for auto manufacturer's tolerances. These minor adjustments may include filing a hole slightly, bending electrical rods or bending end plates.

The BX8869 Bulb and Socket Wiring Kit is recommended for this vehicle.

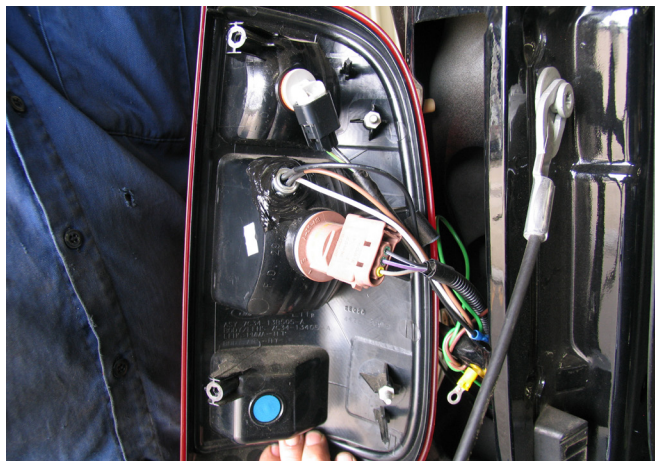

Possible location for the Bulb and Socket Wiring Kit (BX8869)



Installation Instructions:



1. Using a 18MM socket, remove two metric bolts from the bumper, located just beside the fog light assembly. Do this to both sides of the vehicle. Set bolts aside to be reinstalled later.



2. Just behind the metal bumper on the frame down by the headlight, there is a bolt that needs to be removed. Use a 15MM socket. Do this to both sides. Set bolts aside to be reinstalled later.

Do not use the towed vehicle for storing luggage, equipment, etc. This may cause you to exceed the towing capacity of the tow bar, baseplate, and its accessories.

Handling of some cosmetic parts when installing this product may require the use of protective covers, rags, specialty tools, etc. to prevent damage.

BX2618
2008-16 Ford F250
(Includes Super Duty)
Installation Instructions

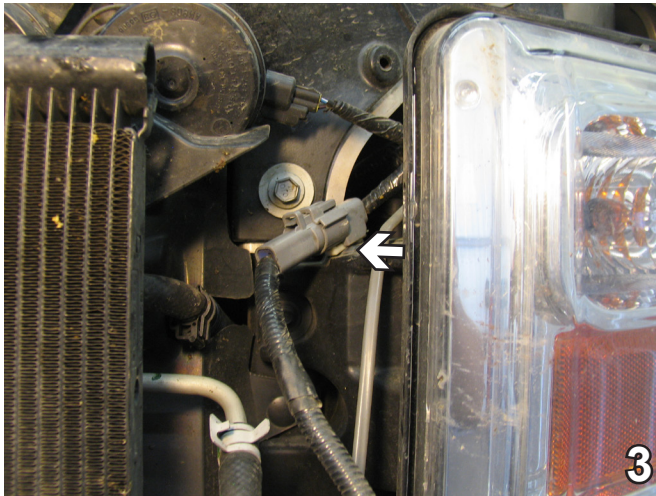

3. By the headlight, unplug the connector that disconnects everything that goes with the bumper. Pull the bumper forward and set aside to be reinstalled later.

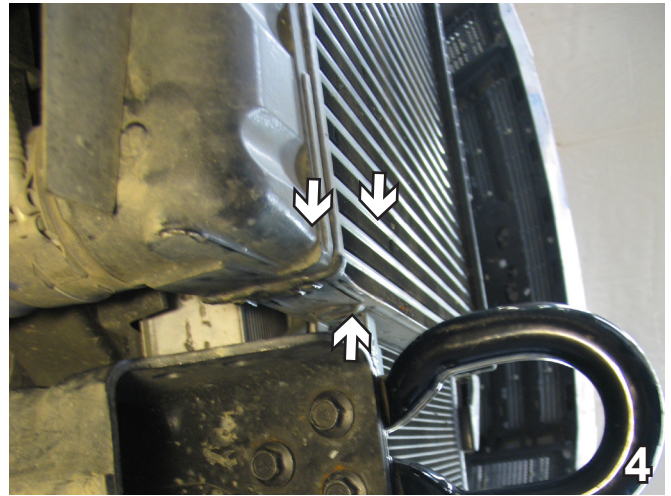

4. Remove the tow hook from both sides by removing the three bolts using an 18MM socket. Set tow hooks and bolts aside--they will not be used again.



5. Models with Turbo cooler will need to loosen and disconnect both clamps, then carefully set cooler aside. Cooler will be reinstalled later.

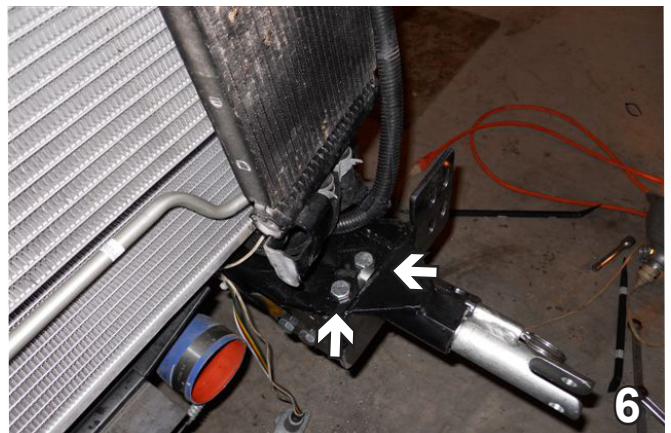

6. Slide baseplate on, align with existing two tow hook holes on the top.

BX2618
2008-16 Ford F250
(Includes Super Duty)
Installation Instructions

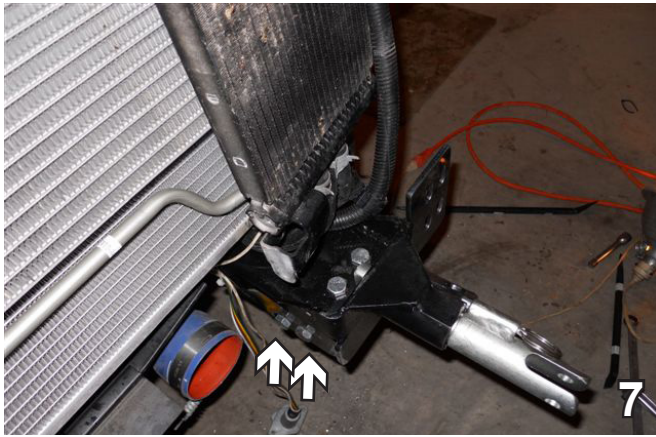

7. First on the interior side, insert 1/2-13 x 1 1/2" hex bolts with 1/2" lock washers and 1/2-13 hex nuts. Do this on both sides. Tighten with Loctite Red.

BE SURE TO USE LOCTITE® RED ON ALL BOLTS BEFORE TIGHTENING. TIGHTEN ALL BOLTS ACCORDING TO THE TORQUE CHART ON THE FRONT PAGE OF THESE INSTRUCTIONS OR ON PAGE 3 OF THE BASEPLATE TOWING GENERAL INSTRUCTIONS.

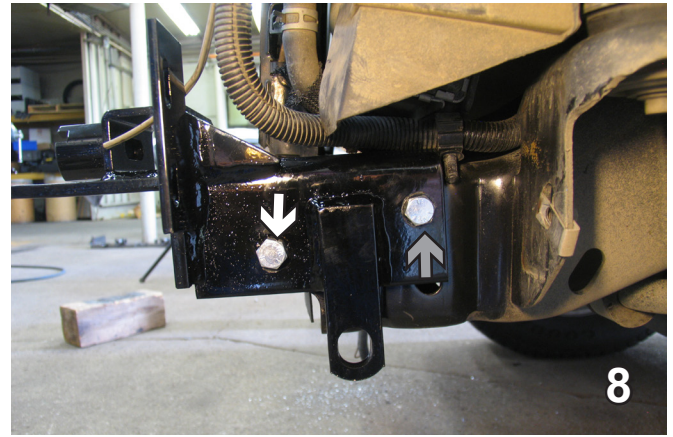

8. On the exterior side, insert 1/2-13 x 1 1/2" hex bolt with 1/2" lock washer and 1/2-13 hex nut in the existing hole. Then the top two. With the baseplate as a template, use a 17/32" drill bit to drill the back hole (grey arrow). Insert bolt, washer and nut. Do this on both sides. Tighten with Loctite Red.
9. Reinstall the turbo cooler.

When using power drills be aware of the dangers of torque and drill bit length.

Be sure that ALL electrical connections are plugged in properly and functioning BEFORE installing the fascia.

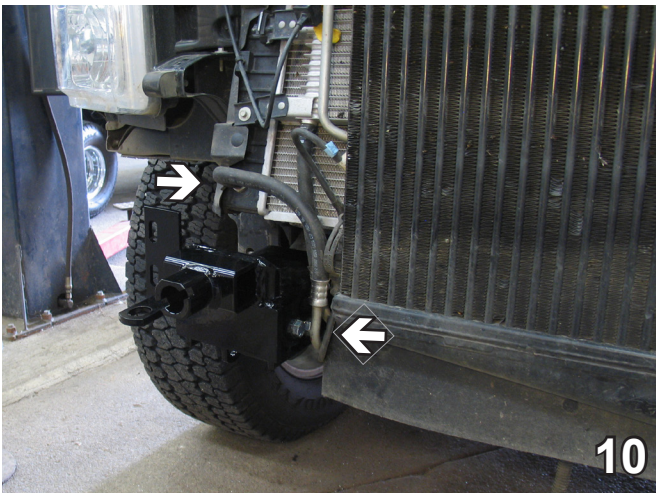

10. Attach the permanent baseplate safety cables to the provided convenience link on the baseplate. The photo above shows the recommended installation of the cables to frame of vehicle (see white arrow). Additional options may interfere with suggested mounting; in this case secure the cables to a solid piece of the frame as described in the instructions included with the permanent baseplate safety cables. Be sure the safety cables do not rub against any hoses or moving parts. Do this to both sides of the vehicle.

Install the tow bar and safety cables according to the instructions provided in their packages. When demonstrating this to the customer, be sure to give all the contents and packages to the consumer.

Do **NOT** substitute other devices if the tow bar pins and clips are misplaced.

11. Reinstall bumper, bolts and reconnect wiring. The installation of the baseplate is complete.

BX2618
2008-16 Ford F250
(Includes Super Duty)
Installation Instructions

DEALER or INSTALLER:
Be certain the user receives the
instruction sheets for their products.



Shown with removable tabs installed



Shown without removable tabs installed

If the baseplate is in an accident, it must be replaced. DO NOT use it again! An accident can cause unseen damage and using it again could result in more damage or serious injury. DO NOT use the baseplate if it is damaged or missing parts.

CUSTOMER SERVICE COMMITMENT

Blue Ox is committed to providing you with exceptional customer care throughout your lifetime with our products. Our team is here to assist you with any questions you may have regarding the performance of your product. Simply call (402) 385-3051 and you can speak with our customer care team.

Additionally, please visit our website to see which rallies our Destination America team will be attending. For a nominal fee, our service technician will service your towing system to ensure it's in proper working condition. Also, as a commitment to our customers, should you visit our factory, you can stay at our full service Blue Ox campground at no charge along with enjoying a factory tour.

Again, thank you for being our customer and for the confidence you have shown in the performance of our products. It is because of customers like you we enjoy the success we have today.

© 2015 Blue Ox
One Mill Road, Industrial Park
Pender, Nebraska 68047
Phone: (402) 385-3051
Fax: (402) 385-3360
www.blueox.com

General Information

1. Ensure that your product(s) are registered online at www.blueox.com. It is crucial to register your product(s) so that you may be alerted of product offerings, updates, upgrades, maintenance and safety bulletins, and/or recalls.
2. **It is the owner's responsibility to inspect all towing equipment for cracked welds, missing or worn parts and loose bolts before each towing trip.** Be sure to use Loctite® Red on all bolts and tighten to the recommended specifications.
3. **It is the owner's responsibility to hook up all towing equipment per manufacturer's instructions/recommendations.**
4. Remove the attachment tabs when not in use (if applicable).

Notice To Baseplate Installer

1. It is YOUR responsibility to watch for:

- Oil cooler and air conditioner lines
- Electrical wires and hoses
- Missing parts or attaching points on the frame

** If the baseplate is improperly installed and is against a wire or hose, it could cause fluid leaks or electrical shorts some time after the actual baseplate installation.

Permanent Baseplate Safety Cable Installation

Permanent baseplate safety cables are strongly recommended when towing a vehicle with a tow bar. The principle function of the permanent baseplate safety cables is to prevent the towed vehicle from breaking loose in the event the connection between the frame of the towed vehicle and the baseplate fails or becomes disconnected. The cables must be connected from the baseplate to the frame rail or cross member of the vehicle's frame. The illustrations below show the possible arrangements recommended by Blue Ox®. Each permanent baseplate safety cable must have an adequate weight rating for the towing system. The weight rating of the two (2) cables together will not qualify.

Do not mount the permanent baseplate safety cables against wires, hoses or brake lines.

These permanent baseplate safety cables should remain installed as long as the baseplate is installed on the vehicle. Permanent baseplate safety cables are to be used in conjunction with, and NOT a replacement for legally required safety cables attaching the towed vehicle to the towing vehicle.

OPTION #1

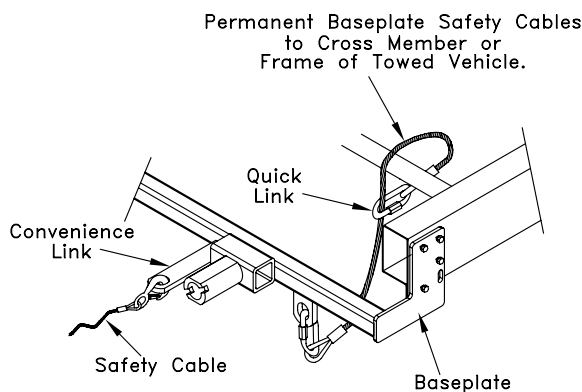

OPTION #2

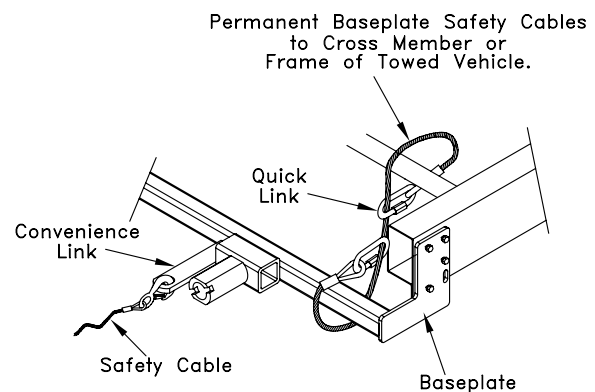

BLUE OX ORIGINAL PURCHASERS THREE YEAR LIMITED WARRANTY

Automatic Equipment Manufacturing Company (“Automatic”) warrants to the original (first) retail purchaser that this product, manufactured by Automatic, shall be free from defect in material and workmanship under normal use and service for a period of three years from the date of delivery.

During said three-year period, Automatic will repair or replace any parts that have been returned by the original purchaser, to the factory, transportation prepaid, and in Automatic’s sole and absolute opinion found to be defective.

Limitations on Warranty Coverage:

Coverage under this warranty will be valid only if the customer warranty card is returned by the original purchaser within 30 days of purchase.

Coverage under this warranty will be effective only when a copy of the original invoice, showing date and place of purchase, accompanies any claim for warranty. This warranty is NON TRANSFERABLE.

This limited warranty will not cover, in any way or form, any alleged damages caused by incorrect or improper installation, improper use, modification or neglect of product, failure to properly service and maintain, misuse, act of God, accident or failure of the user to follow guidelines contained in the instructional material provided by Automatic.

This warranty does not cover normal wear and tear, paint or rust.

Warrantor assumes no responsibility to the owner for loss of use of product, loss of time, inconvenience or any other damage consequential or otherwise. Including, but not limited to mileage, expense of transporting of product, return shipping expense, mechanics travel time, telephone, road service, towing, and rental during repairs, travel, lodging, loss or damage to personal property or loss of earnings.

REPAIR OR REPLACEMENT AS SET FORTH IN THIS LIMITED WARRANTY IS THE SOLE EXCLUSIVE REMEDY OF THE PURCHASER. AUTOMATIC SHALL NOT BE LIABLE FOR ANY INCIDENTAL OR CONSEQUENTIAL DAMAGES FOR BREACH OF ANY EXPRESS OR IMPLIED WARRANTY ON THIS PRODUCT. EXCEPT TO THE EXTENT PROHIBITED BY APPLICABLE LAW, ANY IMPLIED WARRANTY OF MERCHANTABILITY OR FITNESS FOR A PARTICULAR PURPOSE ON THIS PRODUCT IS LIMITED IN LENGTH TO THE DURATION OF THIS WARRANTY.

Please visit <http://blueox.com/warranty/> to register your warranty

