



BX2526

2011 Mazda 3s Hatchback Installation Instructions

Attachment Tab Height: 13.75"

Attachment Tab Width: 24"

Serial Number

Please read BOTH these Installation Instructions and the General Information sheet prior to installing or operating this equipment.

1. Blue Ox® towing products and accessories are intended to be installed by Blue Ox® Dealers who are familiar with our products and have the equipment and knowledge necessary to do "fit work". If needed, Blue Ox® Dealers can be found at www.blueox.com or by contacting our Technical Service Department at (402) 385-3051.
2. Many Blue Ox® baseplates are designed to use existing holes and hardware to mount the baseplate to the towed vehicle. Even though bolts are there, do not assume they are adequate for baseplate mounting. Always use the hardware supplied in the hardware kit and existing hardware as specified in the installation instructions.

Bolt Torque Specifications

Torque in Foot-Pounds for Inch Bolts

Bolt Size	Grade 5	Grade 8
1/4"	10	14
5/16"	19	29
3/8"	33	47
7/16"	54	78
1/2"	78	119
5/8"	154	230
3/4"	257	380



Bolt Torque Specifications

Torque in Foot-Pounds for Metric Bolts

Bolt Size	Grade 8.8	Grade 10.9
6MM	6	8
8MM	16	22
10MM	31	40
12MM	54	70
14MM	89	117
16MM	161	230
18MM	222	318

If the front of your vehicle looks different than this, please contact us at (402)385-3051.

Reference your vehicle owner's manual for manufacturer's towing specifications.



WARNING

Failure to read and follow these instructions could result in separation of the towed vehicle from the tow bar, causing property damage, loss of towed vehicle, personal injury or death.

BX2526 2011 Mazda 3s Hatchback Installation Instructions

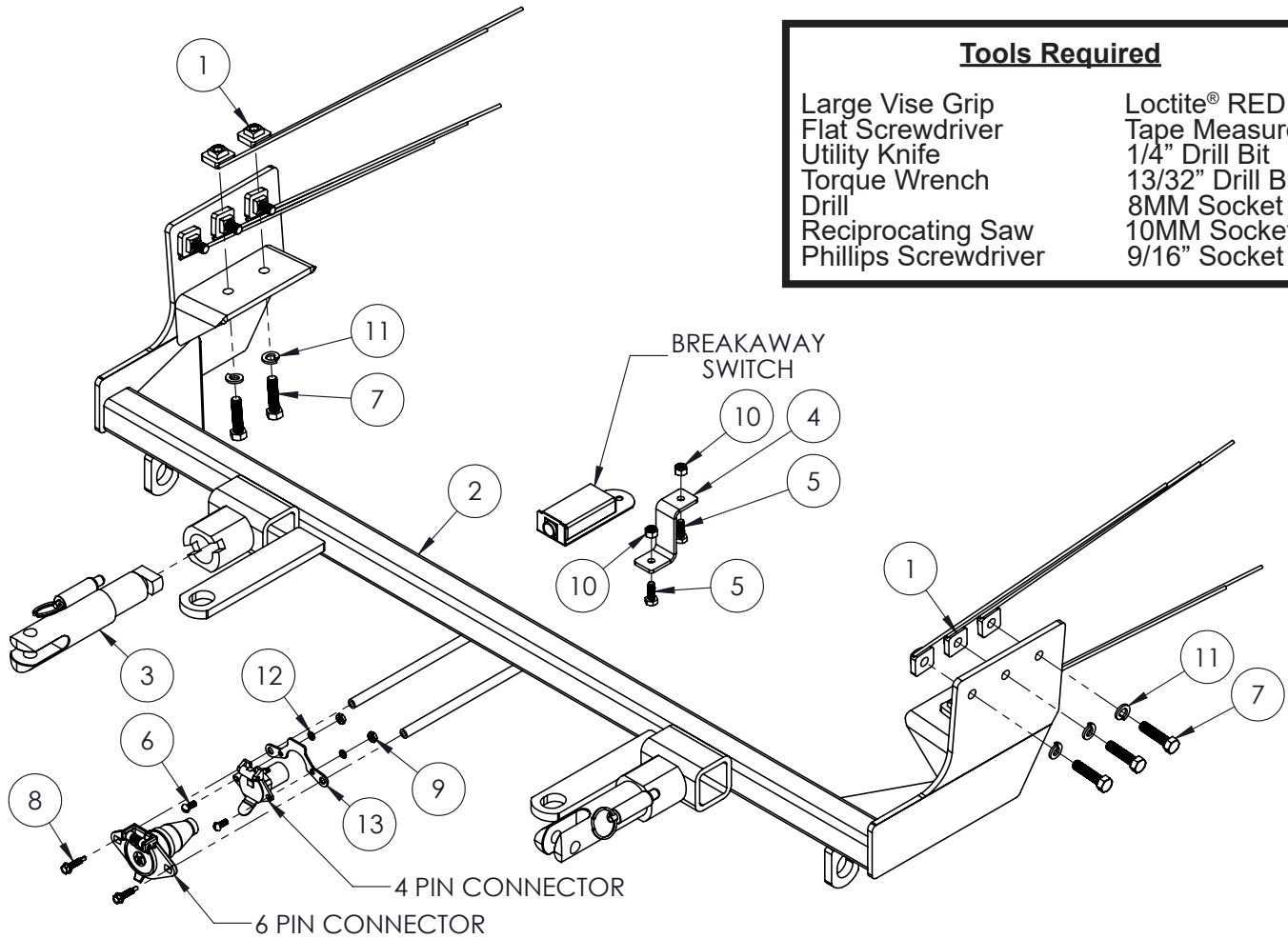

Tools Required	
Large Vise Grip	Loctite® RED
Flat Screwdriver	Tape Measure
Utility Knife	1/4" Drill Bit
Torque Wrench	13/32" Drill Bit
Drill	8MM Socket
Reciprocating Saw	10MM Socket
Phillips Screwdriver	9/16" Socket

Item No.	Part No.	Description	Qty.
1.....	61-5208	3/8"-16 Nut Plate w/ 14" Wire	10
2.....	61-6958	BX2526 Baseplate	1
3.....	62-3468	Attachment Tab Assembly with Hole.....	2
4.....	102-7056	Breakaway/Coolant Bracket	1
5.....	201-0050	1/4"-20 x 3/4" Hex Head Bolt, Grade 5, ZP.....	2
6.....	201-0192	#10-32 x 1/2" Round Slot Head Screw	2
7.....	201-0440	3/8"-16 x 1-1/2" Hex Head Bolt, Grade 5, ZP	10
8.....	201-0979	#12-14 x 1" Self Drilling Screw, ZP	2
9.....	202-0047	#10-32 Hex Nut	2
10.....	202-0102	1/4"-20 Hex Nylon Nut, ZP.....	2
11.....	203-0010	3/8" Lock Washer, ZP	10
12.....	203-0054	#10 Lock Washer	2
13.....	299-0685	Electrical Bracket.....	1
14.....	226-0046(not shown).....	Class III Safety Cables	2
15.....	229-0359(not shown).....	3/8" Quicklink, ZP	2
16.....	290-0159(not shown).....	13" Nylon Cable Tie	1
17.....	290-0437(not shown).....	Black Cap Plug Receiver	2

Important:

Use only genuine factory replacement parts on your baseplate. Do **NOT** substitute homemade or non-typical parts. If a bolt is lost or in need of replacement, for your safety and the preservation of your baseplate, be sure to use a replacement bolt of the same grade (In most cases it will be Grade 5, please reference the parts list above). Replacement parts may be ordered through your nearest Blue Ox® Dealer or Distributor. Failing to follow and/or altering these installation instructions in either installation or required equipment will void the manufacturer's warranty. Towing behind a non-motorized vehicle will void the warranty.

BX2526
2011 Mazda 3s Hatchback
Installation Instructions

Removable Tabs: Due to the design of the removable tabs, the RangeFinder II tow bar can not be used. Adapters, except the BX8833 and BX88151, can not be used with this baseplate.

Instruction Notes: The fascia, bumper side plates and horn with horn bracket are removed and reinstalled for the baseplate installation. Drilling is required. Trimming is required. The washer reservoir relay connection, fog lights and temperature sensor are disconnected and reconnected during installation.

The dimensional variations between otherwise identical vehicles can be considerable. While the baseplate was designed for easy installation, it may be necessary to tailor the baseplate slightly to compensate for auto manufacturer's tolerances. These minor adjustments may include filing a hole slightly, bending electrical rods or bending end plates.

The BX8848 4-Diode Wiring Kit is recommended for this vehicle.

Do not use the towed vehicle for storing luggage, equipment, etc. This may cause you to exceed the towing capacity of the tow bar, baseplate, and its accessories.

Handling of some cosmetic parts when installing this product may require the use of protective covers, rags, specialty tools, etc. to prevent damage.

Installation Instructions:

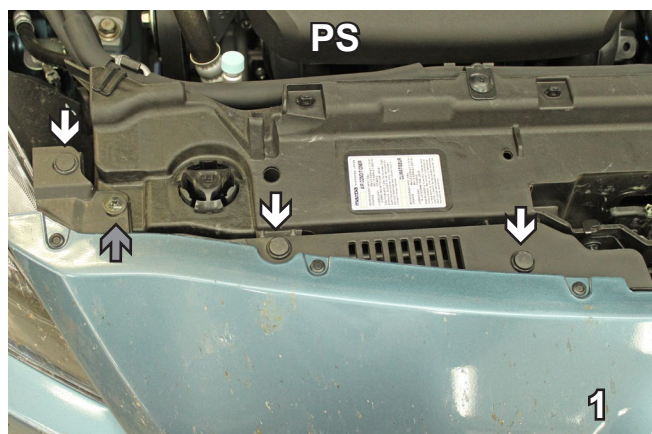
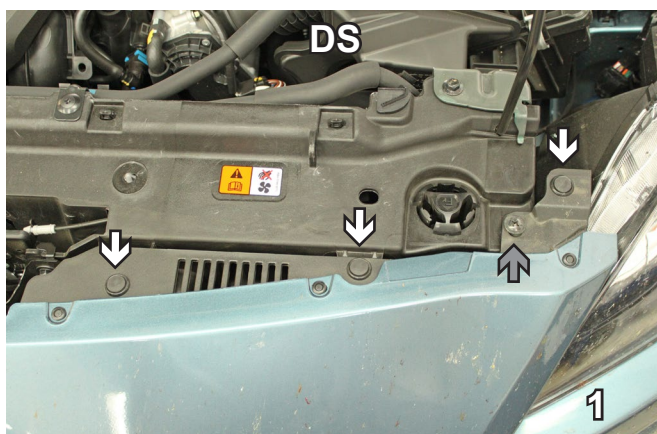

1. With flat screwdriver, remove six (6) push pins from the top of the fascia (white arrows). With a Phillips screwdriver, remove remaining two (2) push pins (gray arrows). Set aside push pins to be reinstalled later.



2. In front of the tire, with a flat screwdriver, remove three (3) push pins (2A). Also, in front of the tire, with an 8MM socket or Phillips screwdriver, remove the one (1) bolt (2B). Do this to both sides of the vehicle. Set aside push pins and bolts to be reinstalled later.

BX2526
2011 Mazda 3s Hatchback
Installation Instructions

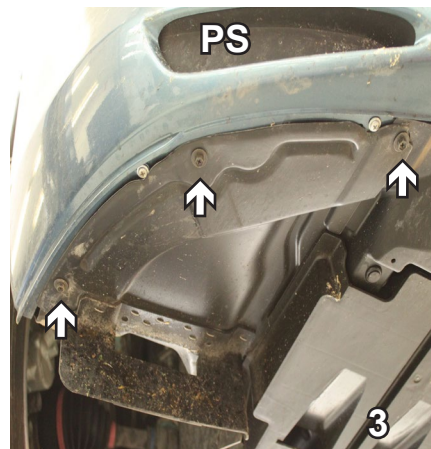
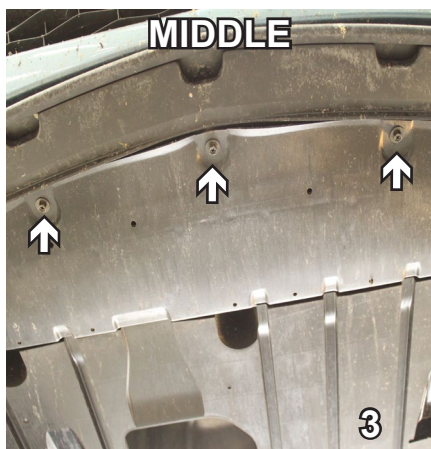
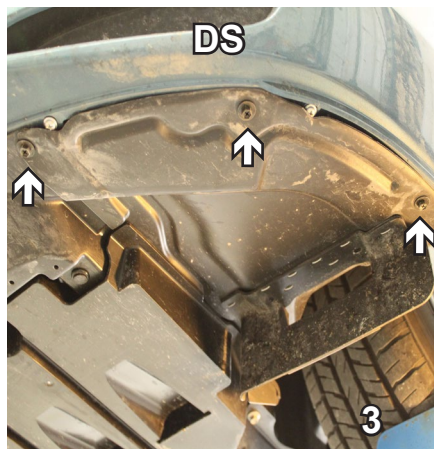

3. With an 8MM socket, remove nine (9) bolts from the underside of the fascia. Set bolts aside to be reinstalled later.



4. Carefully pull forward fascia on passenger side of vehicle. Behind the washer reservoir, unplug the relay connection (white arrow). Disconnect it from the washer reservoir by unclipping it from the back side of the reservoir (gray arrow). Move relay connection aside to be reconnected later.
5. Pull down belly pan underneath the fascia. With a 10MM socket, remove two (2) bolts (one (1) bolt found on each side of the vehicle). Set bolts aside to be reinstalled later.

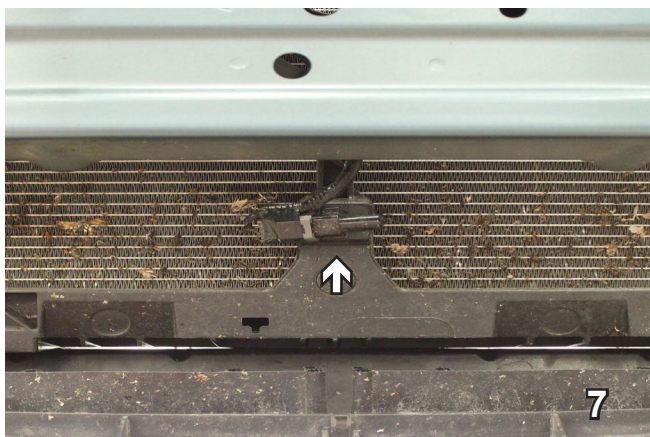

6. Before completely removing the fascia, on passenger side only, disconnect the fog light. Carefully finish removing fascia and set aside to be reinstalled later.
7. Unclip temperature sensor in the front of the radiator, directly under metal bumper and move aside. The temperature sensor will be relocated at a later point in the instructions.

BX2526
2011 Mazda 3s Hatchback
Installation Instructions

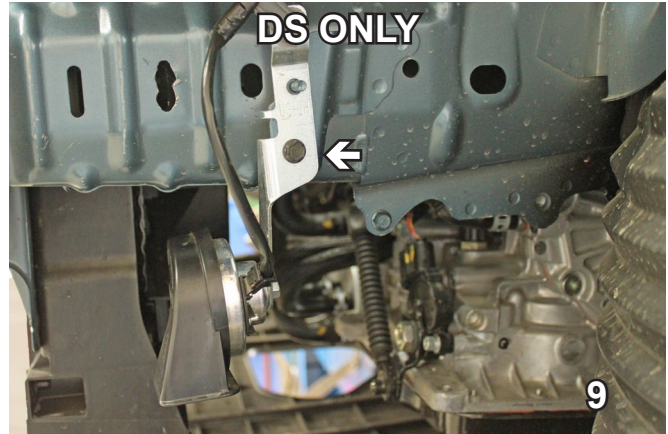
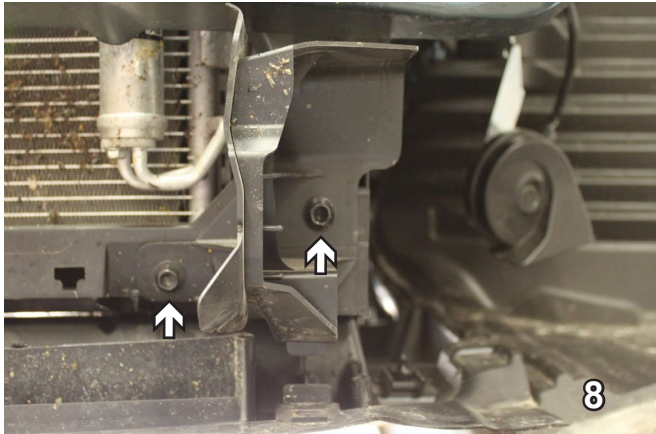

8. With 10MM socket, remove two (2) bolts from the bumper side plate. Set bolts and bumper side plate aside to be reinstalled later. Do this to both sides of the vehicle.
9. On driver's side, with a 10MM socket, remove bolt from horn bracket. Set horn bracket and horn aside to be reinstalled later.

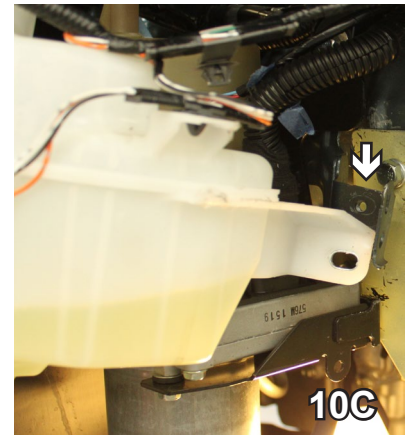
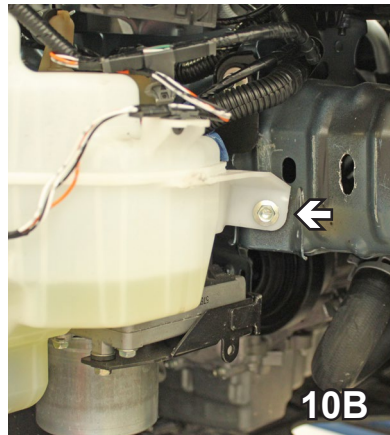

10. On passenger's side, unclip wire harness from bracket on washer reservoir (10A). With a 10MM socket, remove bolt from washer reservoir (10B). Move washer reservoir aside to allow for more room when mounting the baseplate (10C).

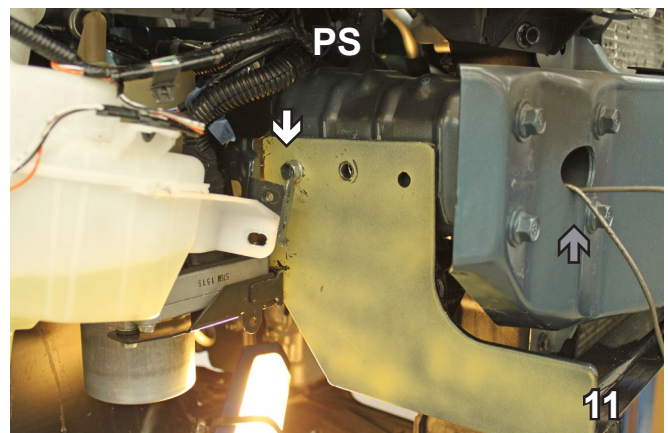
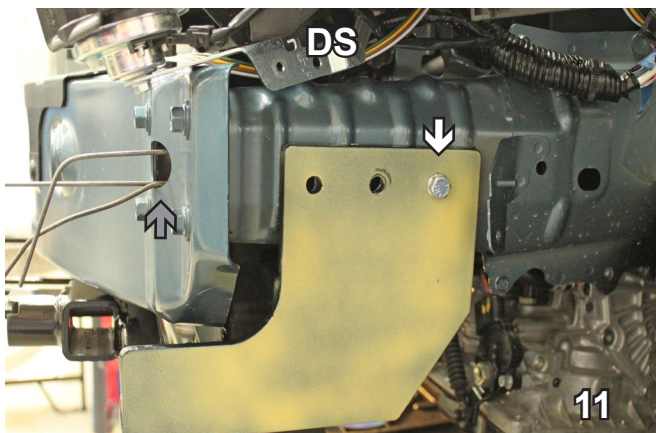

11. When mounting baseplate to the vehicle, use the existing back hole on the bumper horn to align and keep level. Start the 3/8-16 x 1 1/2 hex bolt in the back hole with 3/8" lock washer and nut plate (white arrow). Insert nut plate through existing hole in the front of the bumper (gray arrow). Do this to both sides while always ensuring baseplate remains level. Tighten bolts with Loctite Red. (**Baseplate is painted yellow for demonstrative purposes only.**)

BX2526
2011 Mazda 3s Hatchback
Installation Instructions

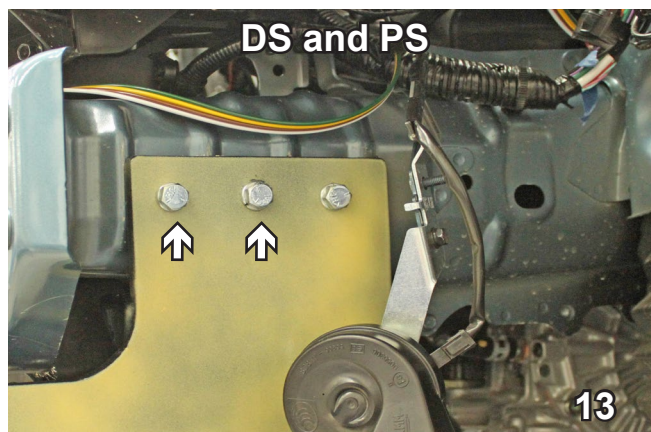
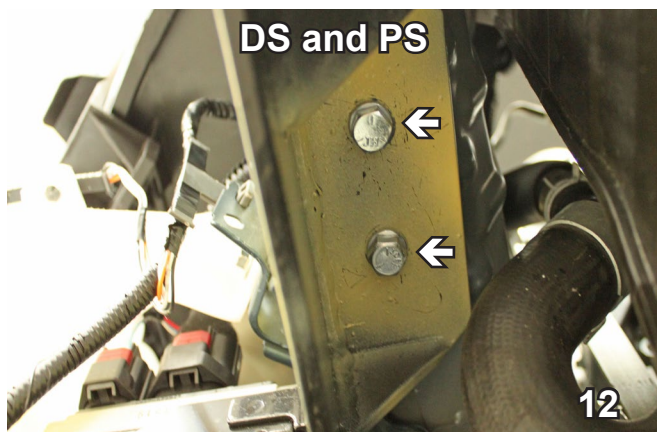

12. Underneath baseplate, with a 13/32" drill bit, drill remaining four (4) holes (two (2) on driver's side, two (2) on passenger's side). Insert 3/8-16 x 1 1/2 hex bolt, 3/8" lock washer and nut plate in each hole. Do this to both sides. Tighten all bolts with Loctite Red.
13. On the side of the baseplate, with a 13/32" drill bit, drill remaining four (4) holes (two (2) on driver's side, two (2) on passenger's side). Insert 3/8-16 x 1 1/2 hex bolt, 3/8" lock washer and nut plate in each hole. Do this to both sides. Tighten all bolts with Loctite Red.

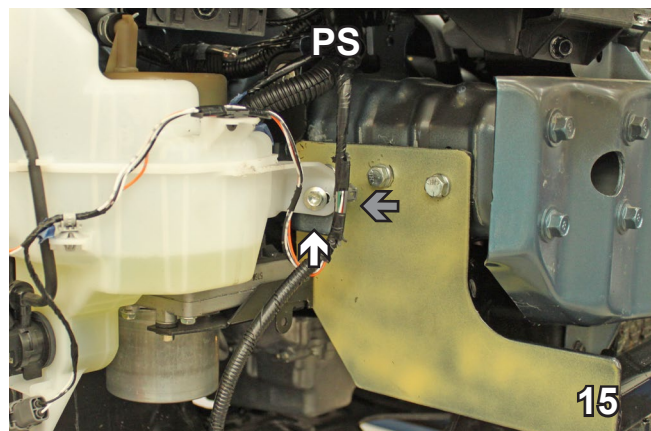
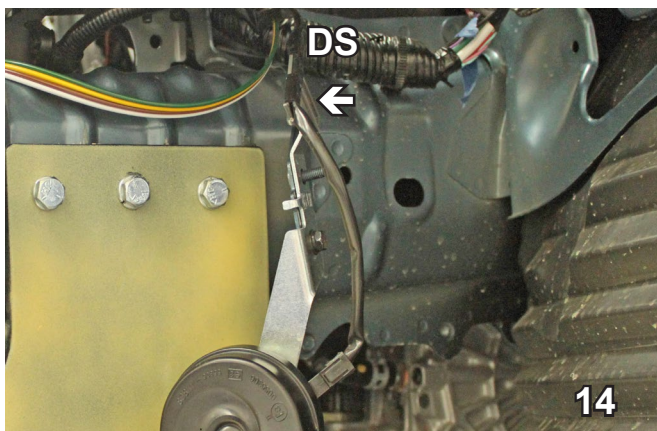

14. On driver's side, with large vise grip, bend horn mounting bracket out to accommodate baseplate. Reattach horn bracket and horn using existing hardware.
15. On passenger's side, reattach washer reservoir to the original bracket using existing hardware (white arrow). Reclip wire harness to the original bracket (grey arrow).

BE SURE TO USE LOCTITE® RED ON ALL BOLTS BEFORE TIGHTENING. TIGHTEN ALL BOLTS ACCORDING TO THE TORQUE CHART ON THE FRONT PAGE OF THESE INSTRUCTIONS OR ON PAGE 3 OF THE BASEPLATE TOWING GENERAL INSTRUCTIONS.

When using power drills be aware of the dangers of torque and drill bit length.

BX2526
2011 Mazda 3s Hatchback
Installation Instructions

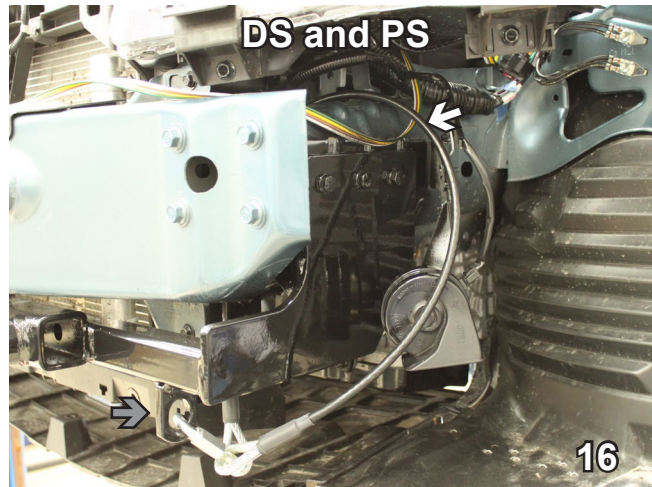

16. Attach the permanent baseplate safety cables to the provided convenience link on the baseplate (gray arrow). The photo to the left shows the recommended installation of the cables to frame of vehicle (white arrow). Additional options may interfere with suggested mounting; in this case secure the cables to a solid piece of the frame as described in the instructions included with the permanent baseplate safety cables. Be sure the safety cables do not rub against any hoses or moving parts. Do this to both sides of the vehicle.

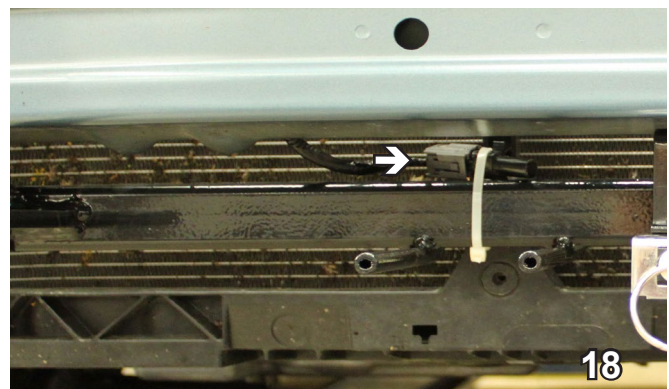
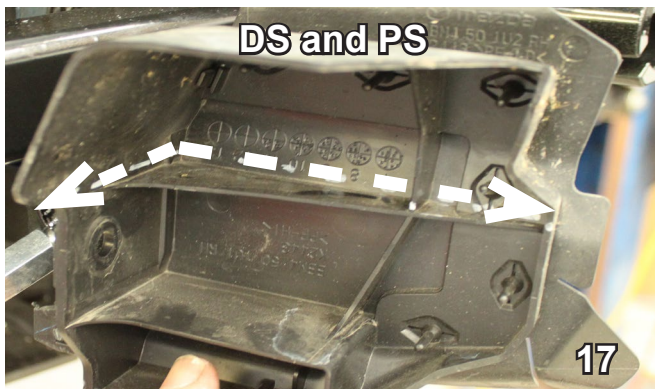

17. Before reinstalling bumper side plate, trimming is required. With a utility knife, trim bumper side plate as shown above. Reinstall bumper side plate using existing hardware. Do this to both sides.
18. Using the provided nylon cable tie, mount temperature sensor to the top of the baseplate.

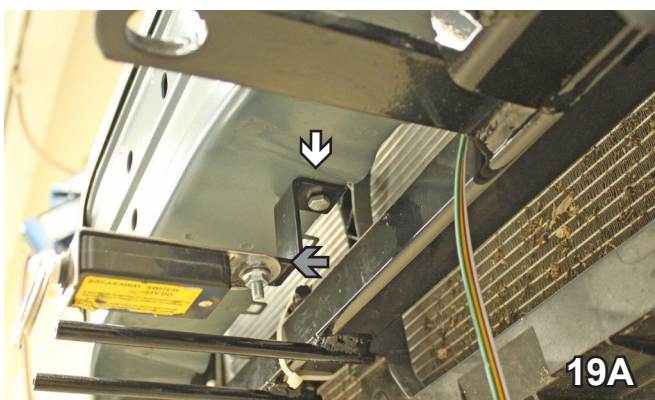

19. **OPTIONAL:** You can install the breakaway bracket and breakaway on either the driver's side or passenger's side of the vehicle. With a 1/4" drill bit, drill a hole through the bottom side of the bumper. Insert 1/4-20 x 3/4 hex bolt (white arrow - 19A) with 1/4-20 hex nylon nut to secure the bracket (19B). Attach breakaway to the bracket with 1/4-20 x 3/4 hex bolt with 1/4-20 hex nylon nut (gray arrow - 19A).

BX2526
2011 Mazda 3s Hatchback
Installation Instructions



20. Hold fascia up as close to original position as possible. With a utility knife, trim fascia to allow baseplate attachment tabs, convenience links and breakaway, if applicable, to come through.

21. Reinstall fascia.

Install the tow bar and safety cables according to the instructions provided in their packages. When demonstrating this to the customer, be sure to include all the contents and packages.

Do not substitute other devices if the tow bar pins and clips are misplaced.

DEALER or INSTALLER:
**Be certain the user receives the
instruction sheets for their products.**

Be sure that **ALL** electrical connections
are plugged in properly and functioning
BEFORE installing the fascia.

BX2526
2011 Mazda 3s Hatchback
Installation Instructions



Shown with removable tabs installed



Shown without removable tabs installed

If the baseplate is in an accident, it must be replaced. DO NOT use it again! An accident can cause unseen damage and using it again could result in more damage or serious injury. DO NOT use the baseplate if it is damaged or missing parts.

CUSTOMER SERVICE COMMITMENT

Blue Ox® is committed to providing you with exceptional customer care throughout your lifetime with our products. Our team is here to assist you with any questions you may have regarding the performance of your product. Simply call (402) 385-3051 and you can speak with our technical service team.

Additionally, please visit our website to see which rallies our Destination America team will be attending. For a nominal fee, our service technician will service your towing system to ensure it's in proper working condition. Also, as a commitment to our customers, should you visit our factory, you can stay at our full service Blue Ox® campground at no charge along with enjoying a factory tour.

Again, thank you for being our customer and for the confidence you have shown in the performance of our products. It is because of customers like you we enjoy the success we have today.

© 2016 Blue Ox
One Mill Road, Industrial Park
Pender, Nebraska 68047
Phone: (402) 385-3051
Fax: (402) 385-3360
www.blueox.com

General Information

1. Ensure that your product(s) are registered online at www.blueox.com. It is crucial to register your product(s) so that you may be alerted of product offerings, updates, upgrades, maintenance and safety bulletins, and/or recalls.
2. **It is the owner's responsibility to inspect all towing equipment for cracked welds, missing or worn parts and loose bolts before each towing trip.** Be sure to use Loctite® Red on all bolts and tighten to the recommended specifications.
3. **It is the owner's responsibility to hook up all towing equipment per manufacturer's instructions/recommendations.**
4. Remove the attachment tabs when not in use (if applicable).

Notice To Baseplate Installer

1. It is YOUR responsibility to watch for:

- Oil cooler and air conditioner lines
- Electrical wires and hoses
- Missing parts or attaching points on the frame

** If the baseplate is improperly installed and is against a wire or hose, it could cause fluid leaks or electrical shorts some time after the actual baseplate installation.

Permanent Baseplate Safety Cable Installation

Permanent baseplate safety cables are strongly recommended when towing a vehicle with a tow bar. The principle function of the permanent baseplate safety cables is to prevent the towed vehicle from breaking loose in the event the connection between the frame of the towed vehicle and the baseplate fails or becomes disconnected. The cables must be connected from the baseplate to the frame rail or cross member of the vehicle's frame. The illustrations below show the possible arrangements recommended by Blue Ox®. Each permanent baseplate safety cable must have an adequate weight rating for the towing system. The weight rating of the two (2) cables together will not qualify.

Do not mount the permanent baseplate safety cables against wires, hoses or brake lines.

These permanent baseplate safety cables should remain installed as long as the baseplate is installed on the vehicle. Permanent baseplate safety cables are to be used in conjunction with, and NOT a replacement for legally required safety cables attaching the towed vehicle to the towing vehicle.

OPTION #1

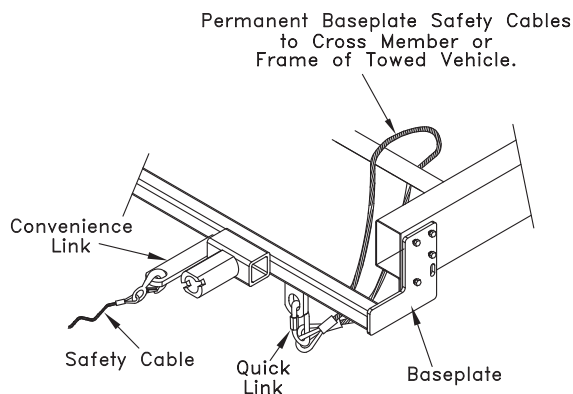

OPTION #2

