



# BX2339

## 2016 Hyundai Elantra Installation Instructions

**Please read BOTH these Installation Instructions and the General Instructions prior to installing or operating this equipment.**

1. Blue Ox® towing products and accessories are intended to be installed by Blue Ox® Dealers who are familiar with our products and have the equipment and knowledge necessary to do “fit work”. If needed, Blue Ox® Dealers can be found at [www.blueox.com](http://www.blueox.com) or by contacting our Customer Care Department at (402) 385-3051.
2. Many Blue Ox® baseplates are designed to use existing holes and hardware to mount the baseplate to the towed vehicle. Even though bolts are there, do not assume they are adequate for baseplate mounting. Always use the hardware supplied in the hardware kit and existing hardware as specified in the installation instructions.

**Attachment Tab Height: 15”**

**Attachment Tab Width: 24”**

**Serial Number**

### Bolt Torque Specifications

Torque in Foot-Pounds for Inch Bolts

Bolt Size	Grade 5	Grade 8
1/4”	10	14
5/16”	19	29
3/8”	33	47
7/16”	54	78
1/2”	78	119
5/8”	154	230
3/4”	257	380



**Sport Model Shown**



**GT Model Shown**

If the front of your vehicle looks different than this, please contact us at (402)385-3051.

### Bolt Torque Specifications

Torque in Foot-Pounds for Metric Bolts

Bolt Size	Grade 8.8	Grade 10.9
6MM	6	8
8MM	16	22
10MM	31	40
12MM	54	70
14MM	89	117
16MM	161	230
18MM	222	318



## WARNING

Failure to read and follow these instructions could result in separation of the towed vehicle from the tow bar, causing property damage, loss of towed vehicle, personal injury or death.

**Reference your vehicle owner’s manual for manufacturer’s towing specifications.**

BX2339  
2016 Hyundai Elantra  
Installation Instructions

**Instruction Notes:** The fascia, air baffle, horns, windshield washer fluid reservoir and bumper are removed and reinstalled for the baseplate installation. Some drilling and trimming is required.

Place all components that are removed on a flat, sturdy surface. All items will be reinstalled unless otherwise noted after the baseplate is installed.

The dimensional variations between otherwise identical vehicles can be considerable. While the baseplate was designed for easy installation, it may be necessary to tailor the baseplate slightly to compensate for vehicle manufacturer's tolerances.

The BX8869 Tail Light Wiring Kit is recommended for the GT model.

The BX8848 4-Diode Wiring Kit is recommended for all other models.



Drill a hole according to the tail  
light wiring kit instructions.

**NOTICE**

- Handling of some cosmetic parts when installing this product may require the use of protective covers, rags, specialty tools, etc. to prevent damage.
- When using power drills be aware of the dangers of torque and drill bit length.
- When using a reciprocating saw be aware of objects behind the cutting surface.
- Use a good quality paint to spray cut edges of frame to prevent rusting.
- Be sure that **ALL** electrical connections are plugged in and accessories are functioning properly before reinstalling the fascia.
- The baseplate is computer tested to your vehicle's GVWR, exceeding this weight will void the manufacturer's warranty.
- Be sure to use a sufficient amount of Loctite® Red on all bolt threads before tightening. Tighten all bolts according to the torque chart provided.
- Dealer or installer be certain the user receives these instruction sheets.
- If the baseplate is in an accident, it must be replaced. **DO NOT** use it again! An accident can cause unseen damage and using it again could result in more damage or serious injury. **DO NOT** use the baseplate if it is damaged or missing parts.

# BX2339 2016 Hyundai Elantra Installation Instructions

## Tools Required

Large Vise Grip	1/4" Drill Bit
Utility Knife	3/8" Drill Bit
Phillips Screwdriver	8MM Socket
Torque Wrench	10MM Socket
Drill	12MM Socket
Reciprocating Saw	7/16" Socket
Tape Measure	7/16" Wrench
Loctite® RED	9/16" Socket
1-1/4" Hole Saw	

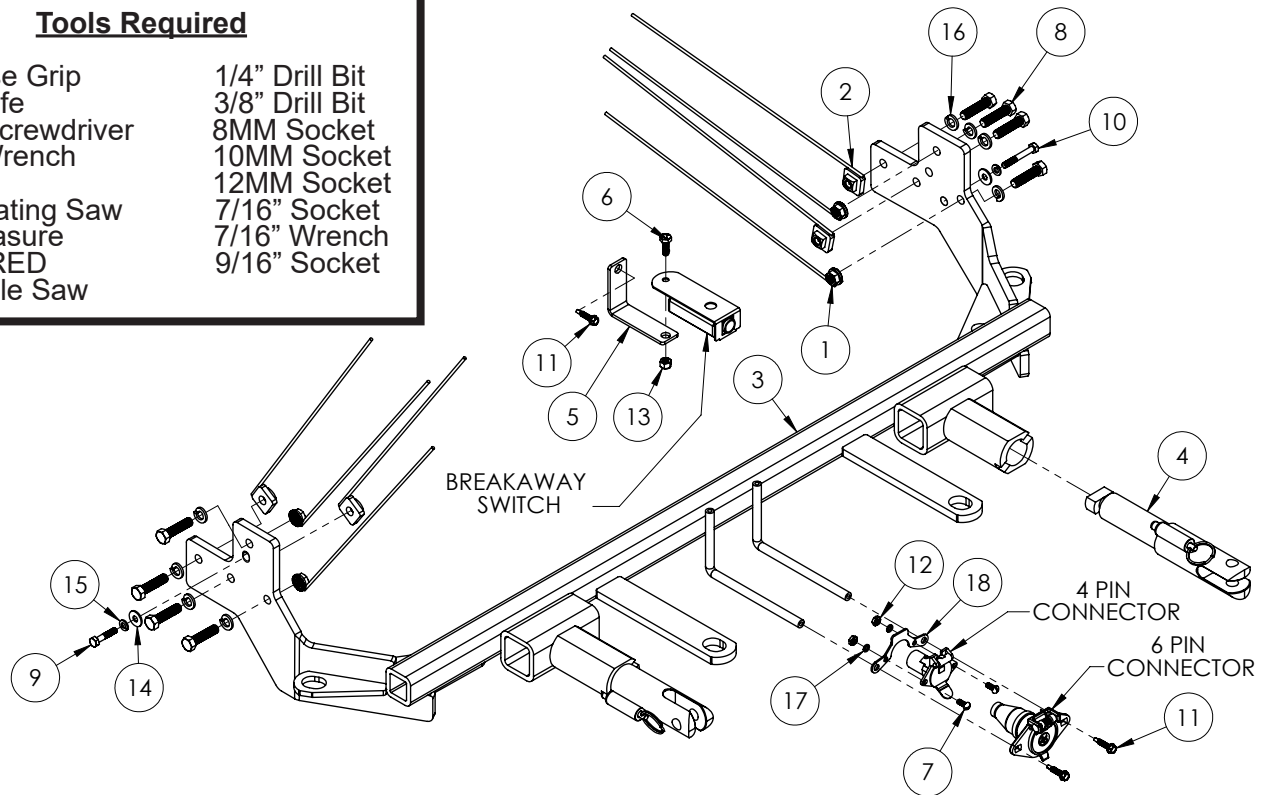

Item No.	Part No.	Description	Qty.
1.....	61-4978 .....	3/8"-16 Whiz Nut w/ 14" Wire .....	4
2.....	61-5208 .....	3/8" Nut Plate w/ 14" Wire .....	4
3.....	61-7534 .....	BX2339 Baseplate.....	1
4.....	62-3469 .....	Attachment Tab Assembly with Hole .....	2
5.....	102-7287 .....	Breakaway Bracket .....	1
6.....	201-0050 .....	1/4"-20 x 3/4" Hex Head Bolt, Grade 5, ZP .....	1
7.....	201-0192 .....	#10-32 1/2" Round Slotted Head Screw.....	2
8.....	201-0440 .....	3/8"-16 x 1-1/2" Hex Head Bolt, Grade 5, ZP .....	8
9.....	201-0655 .....	6MM-1.0 x 30MM Hex Head Bolt, Grade 8.8, ZP .....	1
10.....	201-0702 .....	6MM-1.0 x 45MM Hex Head Bolt, Grade 8.8, ZP .....	1
11.....	201-0979 .....	#12-14 x 1" Self Drilling Screw, ZP.....	3
12.....	202-0047 .....	#10-32 Hex Nut .....	2
13.....	202-0102 .....	1/4"-20 Hex Nylon Nut, ZP .....	1
14.....	203-0001 .....	1/4" Flat Washer, ZP.....	2
15.....	203-0008 .....	1/4" Lock Washer, ZP .....	2
16.....	203-0010 .....	3/8" Lock Washer, ZP .....	8
17.....	203-0054 .....	#10 Lock Washer, ZP .....	2
18.....	299-0685 .....	Electrical Bracket, ZP .....	1
19.....	226-0046(not shown) .....	Class III Safety Cables .....	2
20.....	229-0359(not shown) .....	3/8" Quicklink, ZP .....	2
21.....	290-0437(not shown) .....	Black Cap Plug Receiver.....	2

### Important:

Use only genuine factory replacement parts on your baseplate. Do **NOT** substitute homemade or non-typical parts. If a bolt is lost or in need of replacement, for your safety and the preservation of your baseplate, be sure to use a replacement bolt of the same grade (In most cases it will be Grade 5, please reference the parts list above). Replacement parts may be ordered through your nearest Blue Ox® Dealer or Distributor. Failing to follow and/or altering these installation instructions in either installation or required equipment will void the manufacturer's warranty. Towing behind a non-motorized vehicle will void the warranty.

BX2339  
2016 Hyundai Elantra  
Installation Instructions

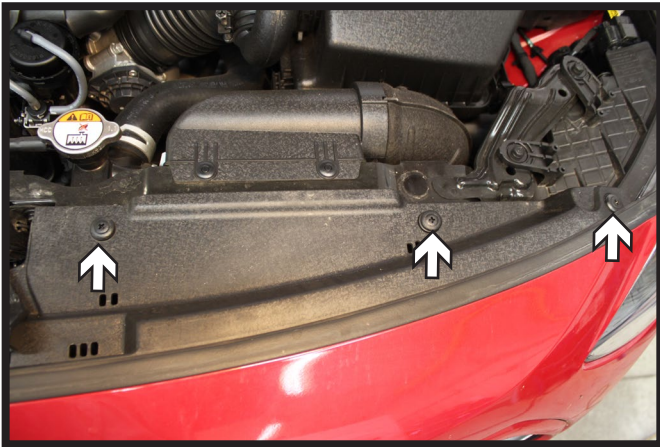

1. Remove the six (6) phillips push pins from the top edge of the fascia. There are three (3) on each side.



2. Using a 8MM or 10MM socket depending on the specific model of vehicle, remove the screw from the fascia/fender joint in the wheel well.

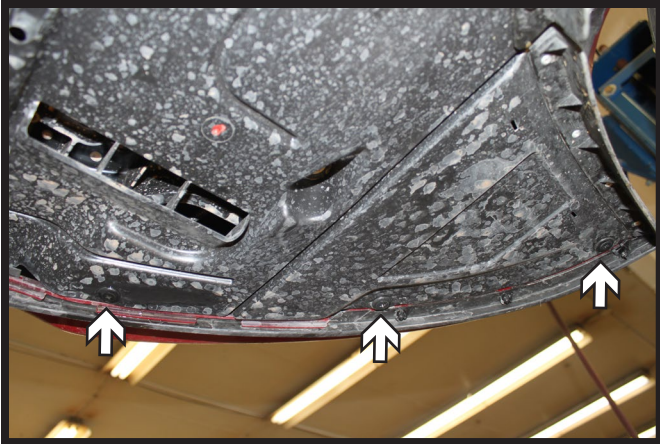

3. Remove the six (6) phillips push pins from the underside of the fascia. There are three (3) on each side.

Pull the corners of the fascia away from the vehicle disconnecting any electrical connections and set the fascia aside.

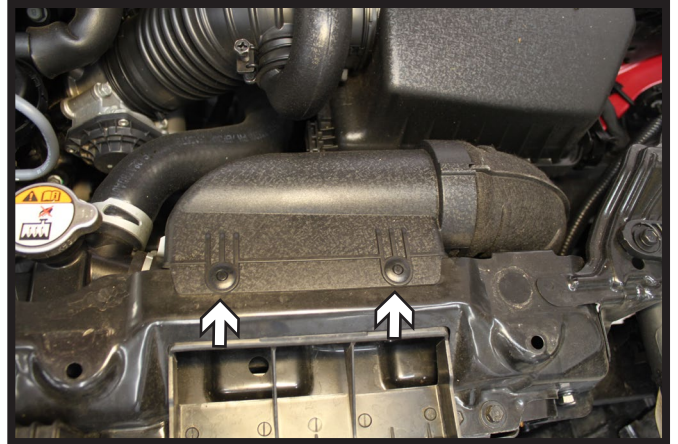

4. Remove the two (2) push pins from the intake tube and pull up to remove from the vehicle.

BX2339  
2016 Hyundai Elantra  
Installation Instructions

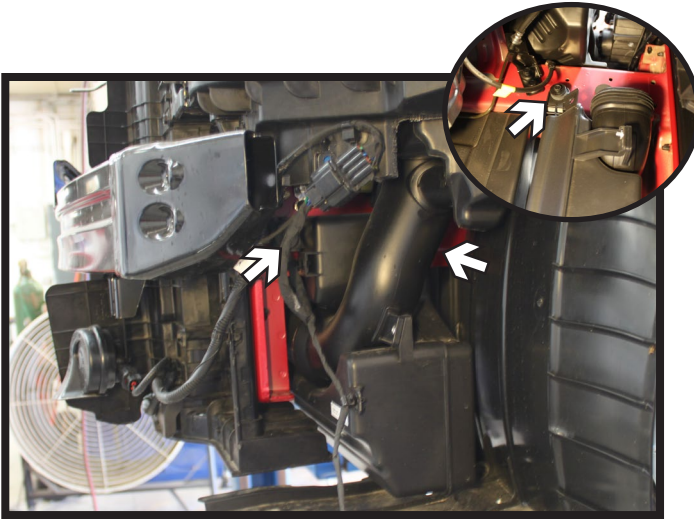

5. Using a 10MM socket, remove the three (3) screws from the air baffle. There are two (2) on the side and one (1) on the bottom side (inset). Set the baffle aside.

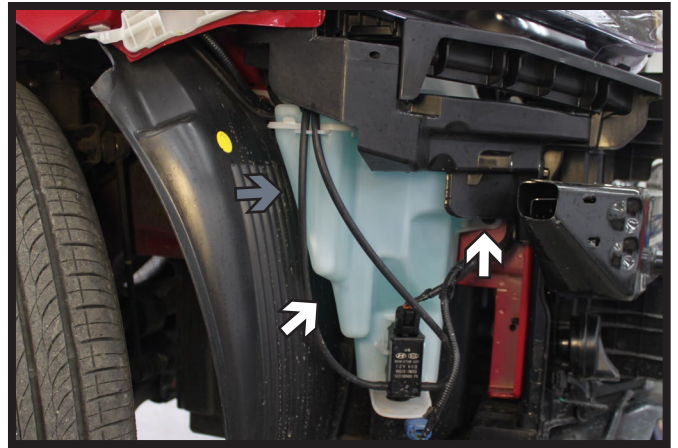

6. Using a 10MM socket, remove the two (2) screws from the washer reservoir (white). Using a phillips screwdriver, remove the upper rear screw (gray). Disconnect/plug all lines and set the reservoir aside.

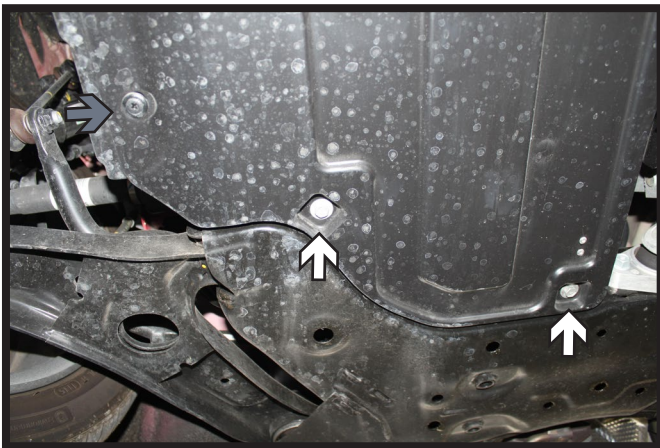

7. Using a 10MM socket, remove the four (4) screws from the belly pan (white). There are two (2) on each side. Then remove the two (2) push pins, one (1) on each side and set the pan aside.

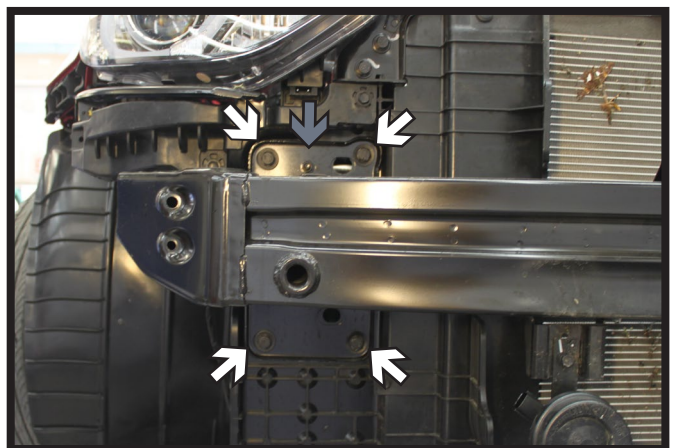

8. Using a 12MM socket, remove the eight (8) bolts from the bumper. There are four (4) on each side (white). Using a 10MM socket, remove the two (2) nuts from the top side of the bumper. There is one (1) on each side (gray). Set the bumper aside.

BX2339  
2016 Hyundai Elantra  
Installation Instructions

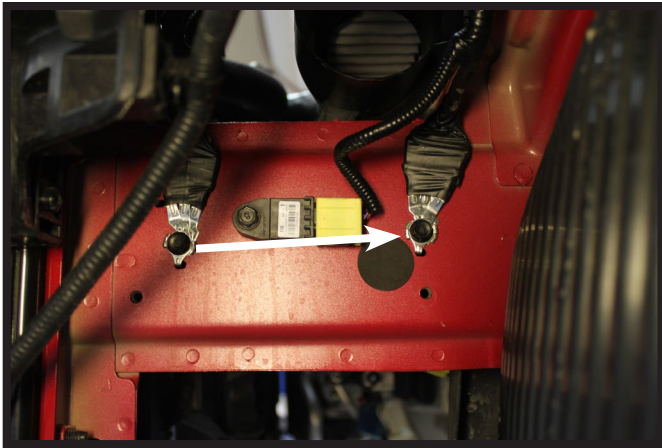

9. On the driver side, using a 10MM socket, relocate the front ground wire to the same location the rear ground wire.

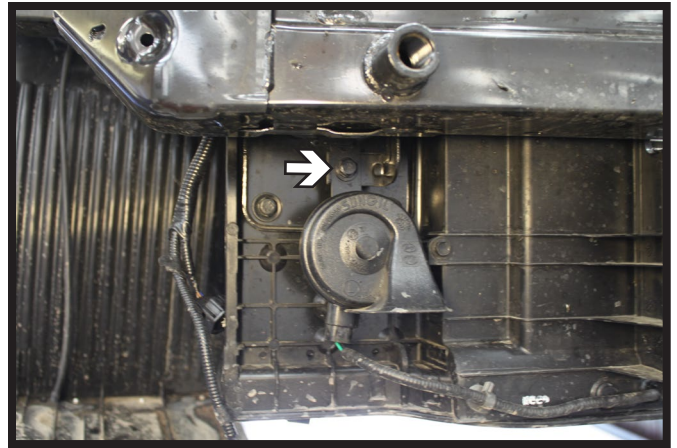

10. Using a 10MM socket, remove the screw from the horn bracket and set the horn aside. Do this on both sides of the vehicle.

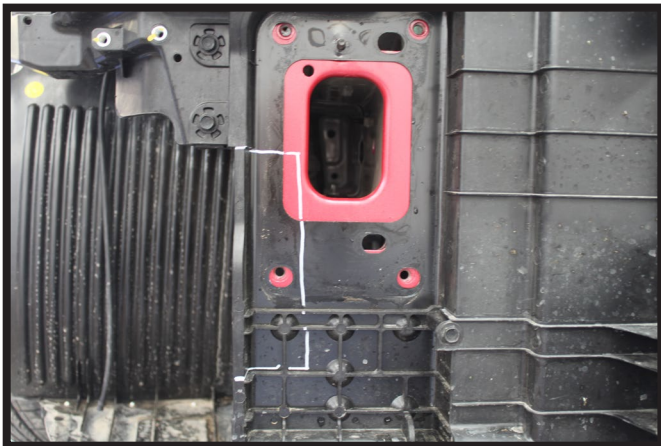

11. Using a reciprocating saw, trim the area as shown back flush to the face of the frame. Do this on both sides of the vehicle.

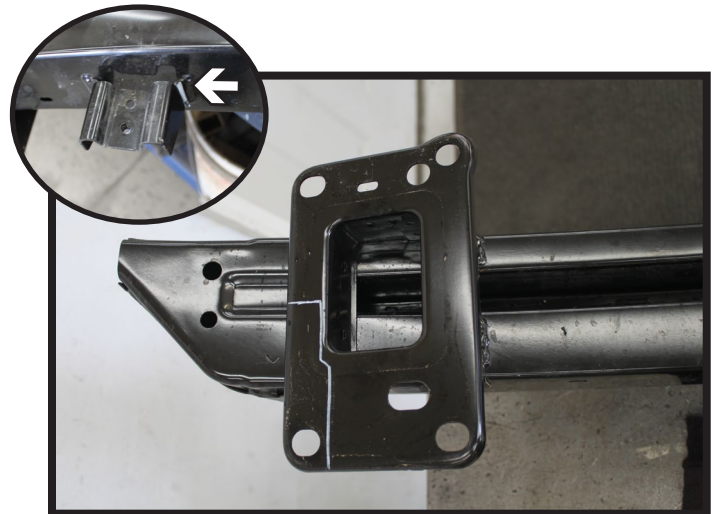

12. Temporarily reinstall the bumper and mark the backside. Remove and trim both ends of the bumper so they sit flush with the frame cuts.

Then trim off the horn bracket mounting tab(s) flush with the bottom of the bumper (inset).

BX2339  
2016 Hyundai Elantra  
Installation Instructions



13. Trim the lower section plastic shielding back flush to the vertical edge. Do this on both sides of the vehicle.  
Reinstall the bumper.

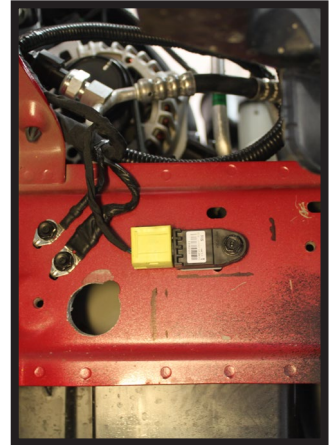
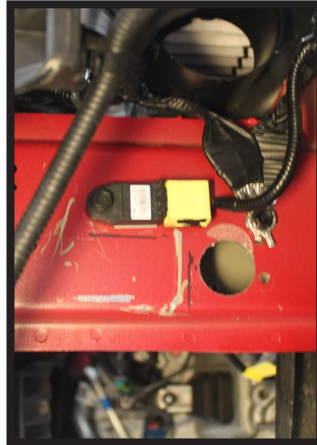

14. On the driver & passenger side frames, using a 1-1/4" hole saw, drill access holes approximately as shown for nut plate access.

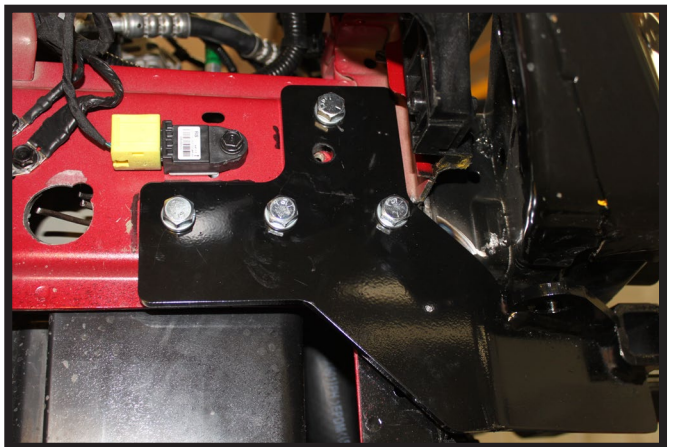
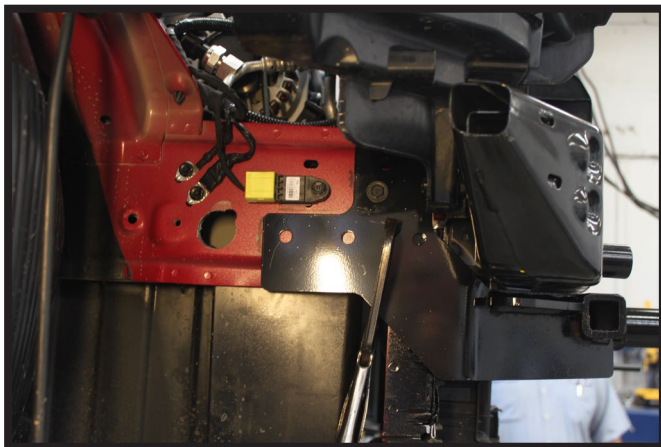

15. Install the baseplate to the frame, aligning the existing holes in the frame to the baseplate. Level and clamp in place. (It is recommended to use the existing bolts to pin the baseplate in place while leveling and clamping, then remove after baseplate bolts are installed)  
Using a 3/8" drill bit, drill the four (4) holes in the baseplate thru the frame and install the 3/8" hardware. Do this on both sides of the vehicle. Fully tighten all hardware.

**\*\* Use Loctite® Red on all bolt threads and tighten all bolts to the appropriate torque.**

BX2339  
2016 Hyundai Elantra  
Installation Instructions

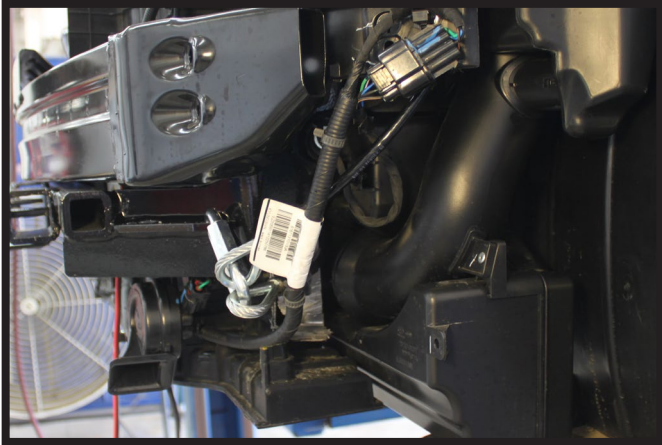

16. Attach the permanent baseplate safety cables to the provided convenience link on the baseplate. The photo above shows the recommended installation of the cables to frame of vehicle. Additional options may interfere with suggested mounting; in this case, secure the cables to a solid piece of the frame as described in the instructions included with the permanent baseplate safety cables. Be sure the safety cables do not rub against any hoses or moving parts. Do this on **BOTH** sides of the vehicle.

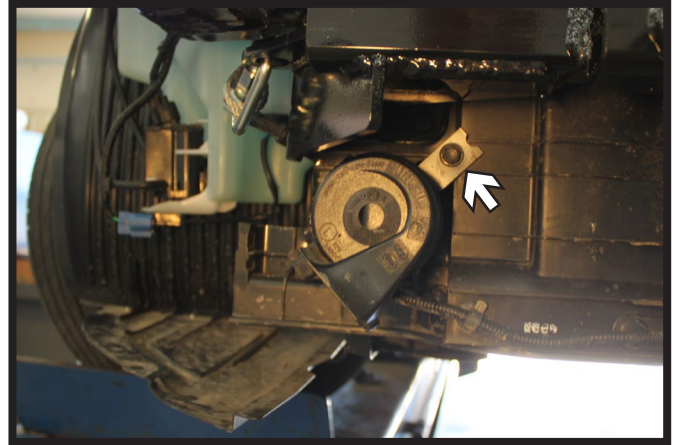

17. Reinstall the horn(s) to the existing bolt locations just below where the original locations.



18. Reinstall the washer reservoir using the provided 6MM-1.0 x 30MM bolt on the front attachment point going thru the baseplate.

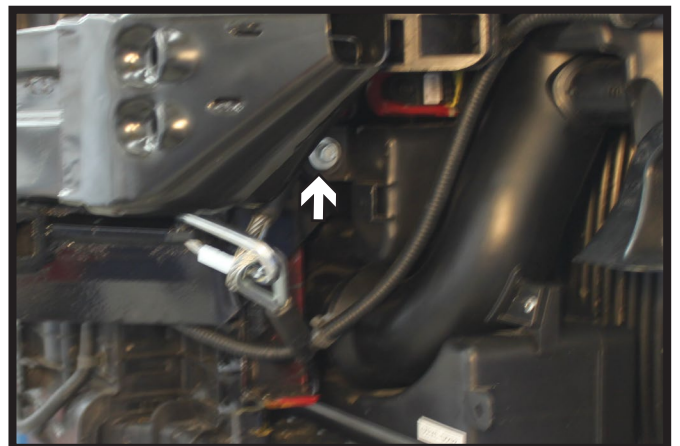

19. Reinstall the air baffle using the provided 6MM-1.0 x 45MM bolt on the front attachment point going thru the baseplate. Reinstall the upper intake tube.



BX2339  
2016 Hyundai Elantra  
Installation Instructions



20. **Optional Breakaway:** At the desired location, attach the bracket to the vehicle with the #12 self drilling screw. Attach the breakaway to the bracket with the supplied 1/4" hardware.



21. Hold the fascia as close to its original position, mark and trim the fascia around the convenience links and attachment tabs. Reinstall the fascia.

## CUSTOMER SERVICE COMMITMENT

Blue Ox® is committed to providing you with exceptional customer care throughout your lifetime with our products. Our team is here to assist you with any questions you may have regarding the performance of your product. Simply call (402) 385-3051 and you can speak with our customer care team.

Additionally, please visit our website to see which rallies our Destination America team will be attending. For a nominal fee, our service technician will service your towing system to ensure it's in proper working condition. Also, as a commitment to our customers, should you visit our factory, you can stay at our full service Blue Ox® campground at no charge along with enjoying a factory tour.

Again, thank you for being our customer and for the confidence you have shown in the performance of our products. It is because of customers like you we enjoy the success we have today.

© 2015 Blue Ox  
One Mill Road, Industrial Park  
Pender, Nebraska 68047  
Phone: (402) 385-3051  
Fax: (402) 385-3360  
www.blueox.com

# General Information

1. Ensure that your product(s) are registered online at [www.blueox.com](http://www.blueox.com). It is crucial to register your product(s) so that you may be alerted of product offerings, updates, upgrades, maintenance and safety bulletins, and/or recalls.
2. **It is the owner's responsibility to inspect all towing equipment for cracked welds, missing or worn parts and loose bolts before each towing trip.** Be sure to use Loctite® Red on all bolts and tighten to the recommended specifications.
3. **It is the owner's responsibility to hook up all towing equipment per manufacturer's instructions/recommendations.**
4. Remove the attachment tabs when not in use (if applicable).

## Notice To Baseplate Installer

### 1. It is YOUR responsibility to watch for:

- Oil cooler and air conditioner lines
- Electrical wires and hoses
- Missing parts or attaching points on the frame

\*\* If the baseplate is improperly installed and is against a wire or hose, it could cause fluid leaks or electrical shorts some time after the actual baseplate installation.

## Permanent Baseplate Safety Cable Installation

Permanent baseplate safety cables are strongly recommended when towing a vehicle with a tow bar. The principle function of the permanent baseplate safety cables is to prevent the towed vehicle from breaking loose in the event the connection between the frame of the towed vehicle and the baseplate fails or becomes disconnected. The cables must be connected from the baseplate to the frame rail or cross member of the vehicle's frame. The illustrations below show the possible arrangements recommended by Blue Ox®. Each permanent baseplate safety cable must have an adequate weight rating for the towing system. The weight rating of the two (2) cables together will not qualify.

***Do not mount the permanent baseplate safety cables against wires, hoses or brake lines.***

These permanent baseplate safety cables should remain installed as long as the baseplate is installed on the vehicle. Permanent baseplate safety cables are to be used in conjunction with, and NOT a replacement for legally required safety cables attaching the towed vehicle to the towing vehicle.

### OPTION #1

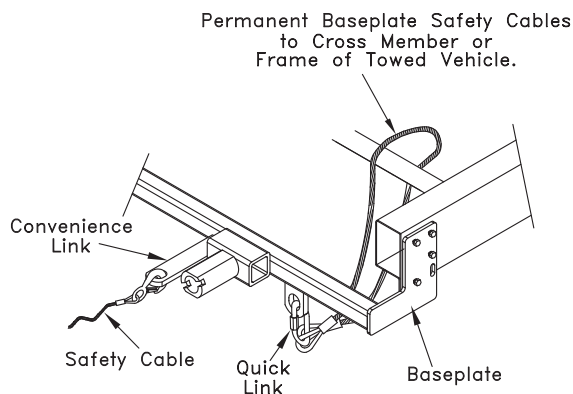

### OPTION #2

