



BX2337

2013-2015 Hyundai Genesis Coupe Installation Instructions

Attachment Tab Height: 16"

Attachment Tab Width: 20"

Serial Number

Please read BOTH these Installation Instructions and the General Instructions prior to installing or operating this equipment.

1. Blue Ox® towing products and accessories are intended to be installed by Blue Ox® Dealers who are familiar with our products and have the equipment and knowledge necessary to do "fit work". If needed, Blue Ox® Dealers can be found at www.blueox.com or by contacting our Customer Care Department at (402) 385-3051.
2. Many Blue Ox® baseplates are designed to use existing holes and hardware to mount the baseplate to the towed vehicle. Even though bolts are there, do not assume they are adequate for baseplate mounting. Always use the hardware supplied in the hardware kit and existing hardware as specified in the installation instructions.



If the front of your vehicle looks different than this, please contact us at (402)385-3051.

Reference your vehicle owner's manual for manufacturer's towing specifications.

Bolt Torque Specifications

Torque in Foot-Pounds for Inch Bolts

Bolt Size	Grade 5	Grade 8
1/4"	10	14
5/16"	19	29
3/8"	33	47
7/16"	54	78
1/2"	78	119
5/8"	154	230
3/4"	257	380

Bolt Torque Specifications

Torque in Foot-Pounds for Metric Bolts

Bolt Size	Grade 8.8	Grade 10.9
6MM	6	8
8MM	16	22
10MM	31	40
12MM	54	70
14MM	89	117
16MM	161	230
18MM	222	318



WARNING

Failure to read and follow these instructions could result in separation of the towed vehicle from the tow bar, causing property damage, loss of towed vehicle, personal injury or death.

BX2337
2013-2015 Hyundai Genesis Coupe
Installation Instructions

Instruction Notes: The fascia, PS headlight and windshield washer fluid reservoir are removed and reinstalled for the baseplate installation. The metal bumper is removed and not reinstalled for the baseplate installation. Some drilling and trimming is required.

Place all components that are removed on a flat, sturdy surface. All items will be reinstalled unless otherwise noted after the baseplate is installed.

The dimensional variations between otherwise identical vehicles can be considerable. While the baseplate was designed for easy installation, it may be necessary to tailor the baseplate slightly to compensate for vehicle manufacturer's tolerances.

The BX8848 4-Diode Wiring Kit is recommended for this vehicle.

NOTICE

- Handling of some cosmetic parts when installing this product may require the use of protective covers, rags, specialty tools, etc. to prevent damage.
- When using power drills be aware of the dangers of torque and drill bit length.
- When using a reciprocating saw be aware of objects behind the cutting surface.
- Use a good quality paint to spray cut edges of frame to prevent rusting.
- Be sure that **ALL** electrical connections are plugged in and accessories are functioning properly before reinstalling the fascia.
- The baseplate is computer tested to your vehicle's GVWR, exceeding this weight will void the manufacturer's warranty.
- Be sure to use Loctite® Red on all bolts before tightening. Tighten all bolts according to the torque chart provided.
- Dealer or installer be certain the user receives these instruction sheet.
- If the baseplate is in an accident, it must be replaced. **DO NOT** use it again! An accident can cause unseen damage and using it again could result in more damage or serious injury. **DO NOT** use the baseplate if it is damaged or missing parts.

BX2337

2013-2015 Hyundai Genesis Coupe

Installation Instructions

<u>Tools Required</u>	
Large Vise Grip	8MM Socket
Utility Knife	10MM Socket
Phillips Screwdriver	12MM Socket
Torque Wrench	14MM Socket
Drill	7/16" Socket
Reciprocating Saw	7/16" Wrench
Tape Measure	9/16" Socket
Loctite® RED	9/16" Wrench
13/32" Drill Bit	

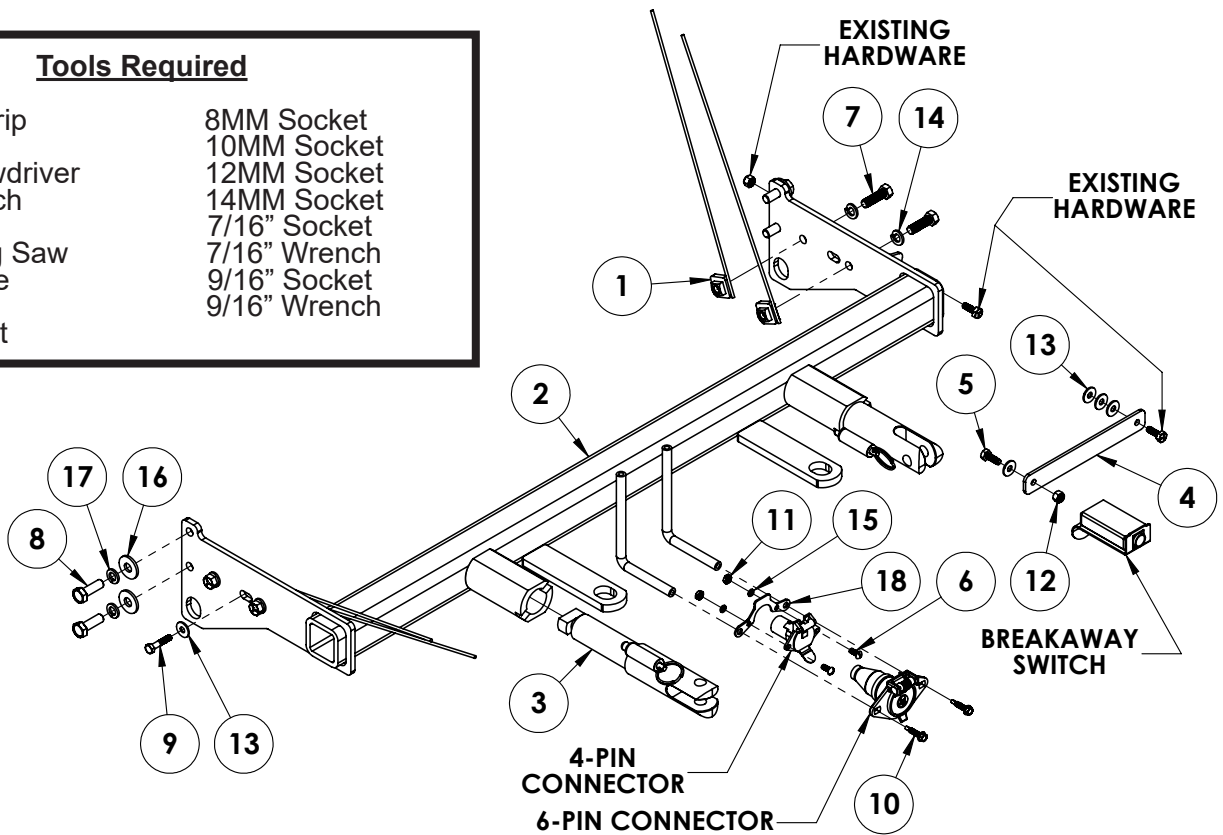

Item No.	Part No.	Description	Qty.
1.....	61-5208	3/8"-16 Nut Plate w/ 14" Wire	4
2.....	61-7250	BX2337 Baseplate.....	1
3.....	62-3469	Attachment Tab Assembly with Hole	2
4.....	101-8319	BX2337 Breakaway Bracket.....	1
5.....	201-0050	1/4"-20 x 3/4" Hex Head Bolt, Grade 5, ZP	1
6.....	201-0192	#10-32 1/2" Round Slotted Head Screw.....	2
7.....	201-0368	3/8"-16 x 1-1/4" Hex Head Bolt, Grade 5, ZP	4
8.....	201-0422	10MM-1.25 x 30MM Hex Head Bolt, Grade 8.8, ZP	4
9.....	201-0655	6MM-1.0 x 30MM Hex Head Bolt, Grade 8.8, ZP	1
10.....	201-0979	#12-14 x 1" Self Drilling Screw, ZP	2
11.....	202-0047	#10-32 Hex Nut	2
12.....	202-0102	1/4"-20 Hex Nylon Nut, ZP	1
13.....	203-0001	1/4" Flat Washer, ZP.....	5
14.....	203-0010	3/8" Lock Washer, ZP	4
15.....	203-0054	#10 Lock Washer, ZP	2
16.....	203-0103	10MM Flat Washer, ZP.....	4
17.....	203-0104	10MM Lock Washer, ZP	4
18.....	299-0685	Electrical Bracket.....	1
19.....	226-0046(not shown)	Class III Safety Cables	2
20.....	229-0359(not shown)	3/8" Quicklink, ZP	2
21.....	290-0437(not shown)	Black Cap Plug Receiver.....	2

Important:

Use only genuine factory replacement parts on your baseplate. Do **NOT** substitute homemade or non-typical parts. If a bolt is lost or in need of replacement, for your safety and the preservation of your baseplate, be sure to use a replacement bolt of the same grade (In most cases it will be Grade 5, please reference the parts list above). Replacement parts may be ordered through your nearest Blue Ox® Dealer or Distributor. Failing to follow and/or altering these installation instructions in either installation or required equipment will void the manufacturer's warranty. Towing behind a non-motorized vehicle will void the warranty.

BX2337
2013-2015 Hyundai Genesis Coupe
Installation Instructions

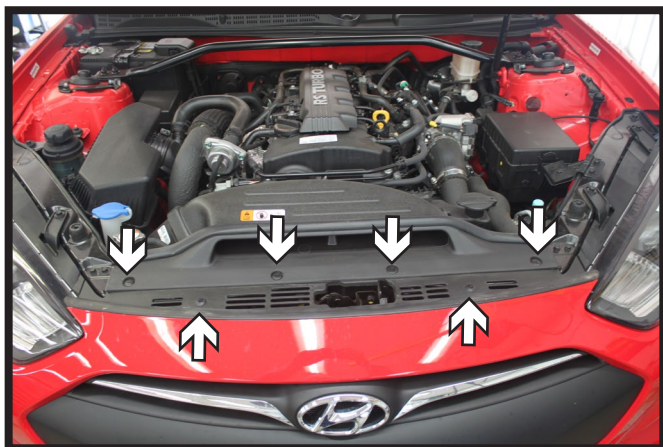

1. Remove the six (6) Phillips head push pins from the top edge of the fascia.



2. Using a 8MM socket or Phillips screwdriver, remove the screw from the top edge of the wheel well. Do this on both sides of the vehicle.



3. Remove the four (4) Phillips head push pins from the underside of the fascia. There are two (2) on each side.

Remove the fascia from the vehicle, disconnecting any electrical lines and set the fascia aside.

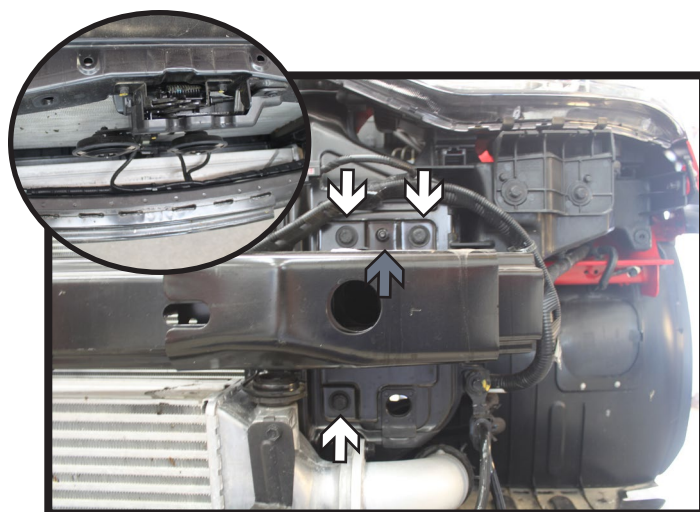

4. Unsnap the wiring loom from the backside of the fascia (inset). Using a 12MM socket, remove the three (3) bolts from the bumper (white). Then using a 10MM socket, remove the remaining bolt from the bumper (gray). Do this on both sides of the vehicle. The bumper will not be reinstalled.

BX2337
2013-2015 Hyundai Genesis Coupe
Installation Instructions

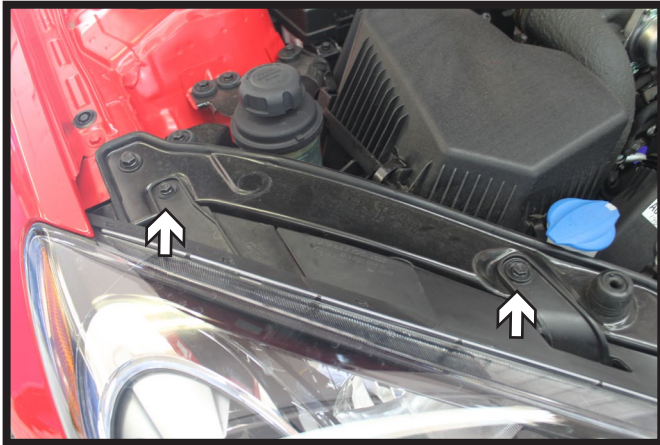

5. Using a 10MM socket, remove the two (2) screws from the passenger side headlight. Disconnect the wiring and set aside.

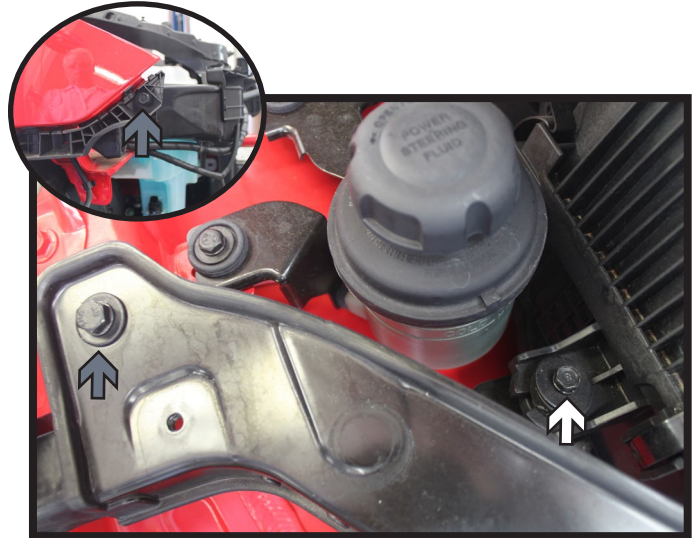

6. Underneath the passenger side headlight, using a 10MM socket, remove the screw from the brace (white). Then using a 12MM socket, remove the screws from the top and side of the brace (gray).

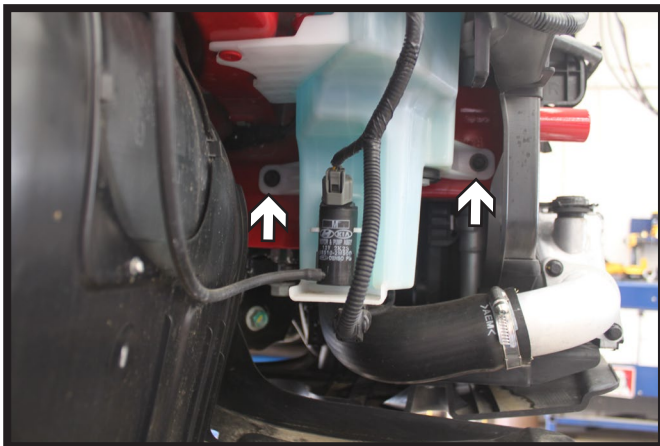

7. Using a 10MM socket, remove the two (2) screws from the washer reservoir. Disconnect/plug lines and set the reservoir aside.

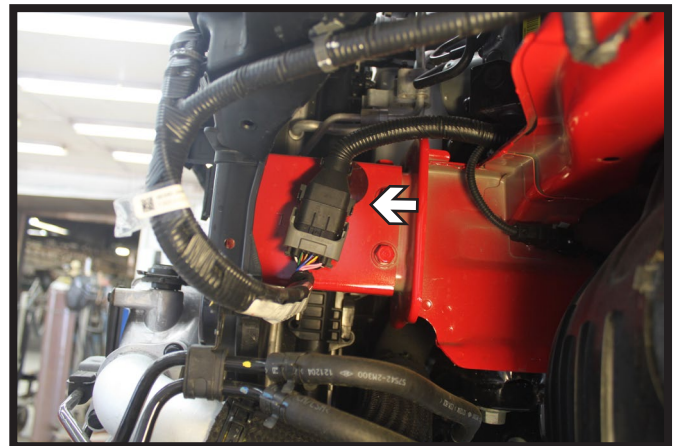

8. On the driver side, remove the wiring harness from the frame.

BX2337
2013-2015 Hyundai Genesis Coupe
Installation Instructions

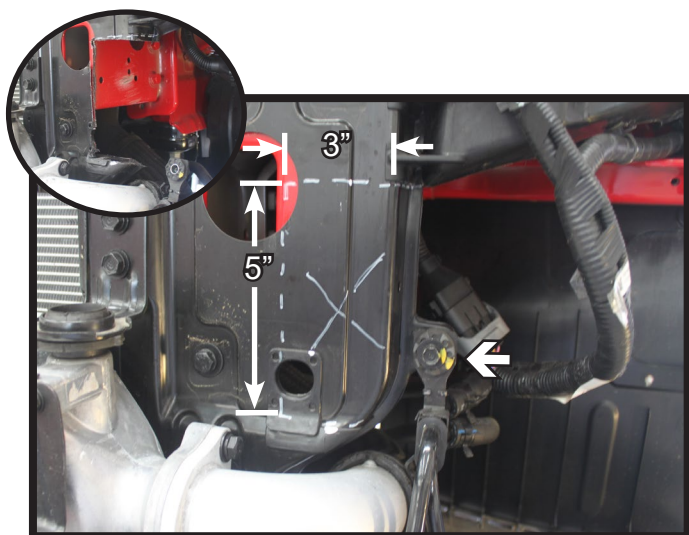

9. Using a 10MM socket, remove the screw from the cooler line. Trim the face of the frame 3" over and 5" down as shown for baseplate clearance. Do this on both sides of the vehicle.

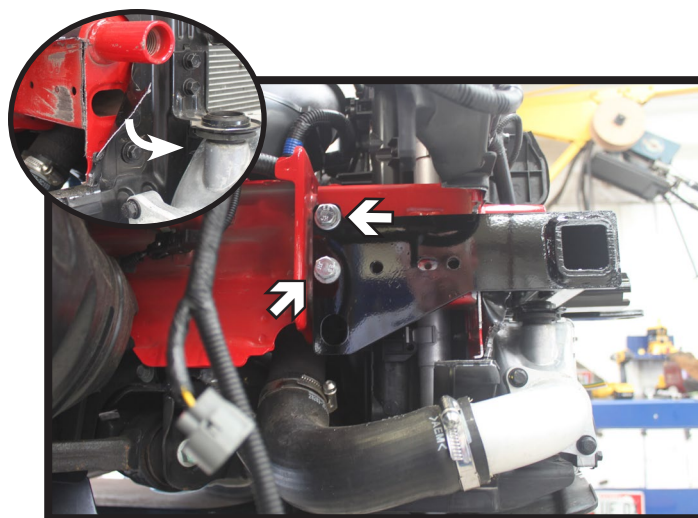

10. On the passenger side, bend the frame face over to allow nut plate access (inset). Position the baseplate onto the vehicle. Install two (2) 10MM-1.25 bolts with 10MM lock washers into the existing holes at the rear of the baseplate. Do this on both sides of the vehicle. Fully tighten all hardware.

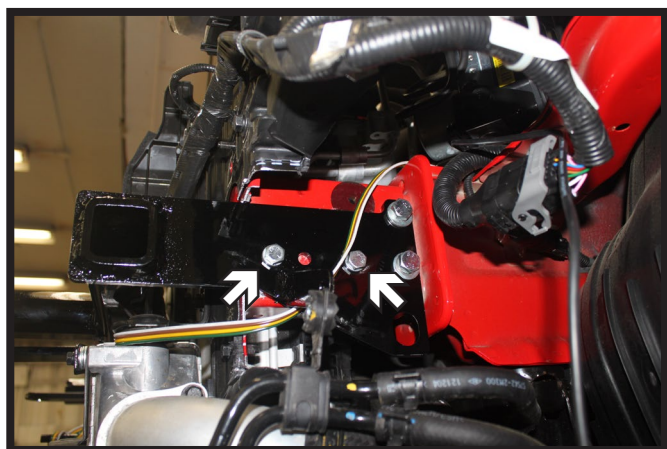

11. Using a 13/32" drill bit, drill the two (2) remaining holes in the sideplate thru the frame. Install 3/8"-13 x 1-1/4" bolts with 3/8" lock washers into the holes and 3/8" nut plates on the inside of the frame. Do this on both sides of the vehicle. Fully tighten all hardware.
Note: After passenger side nut plates are installed the frame face can be bent back.

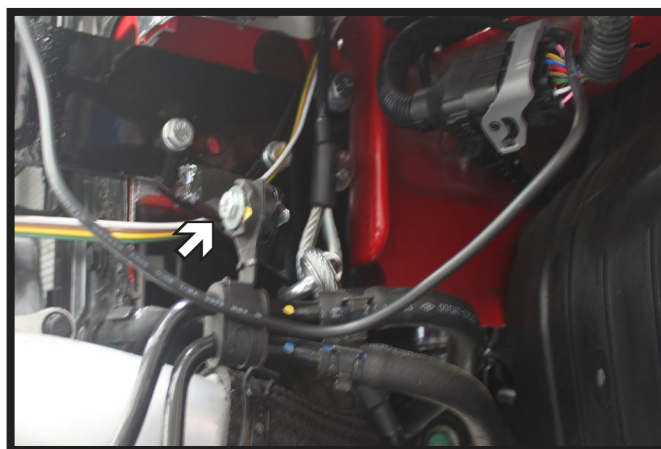

12. On the driver side, reinstall the coolant line to the baseplate tab with the existing hardware.

BX2337
2013-2015 Hyundai Genesis Coupe
Installation Instructions

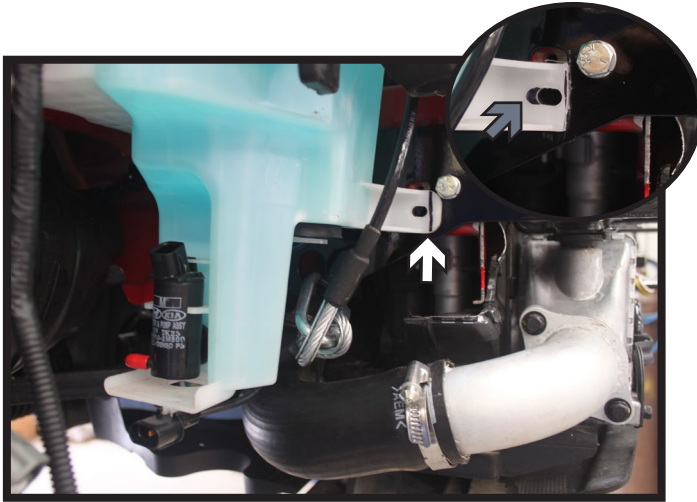

13. Trim approximately 1/4" of the tab of the washer reservoir for clearance of the bolt. Reinstall the reservoir starting the back bolt first then the front bolt.
Note: The front slot may need to be elongated slightly for bolt clearance (gray).

Reinstall the support bracket bolts and passenger headlight.

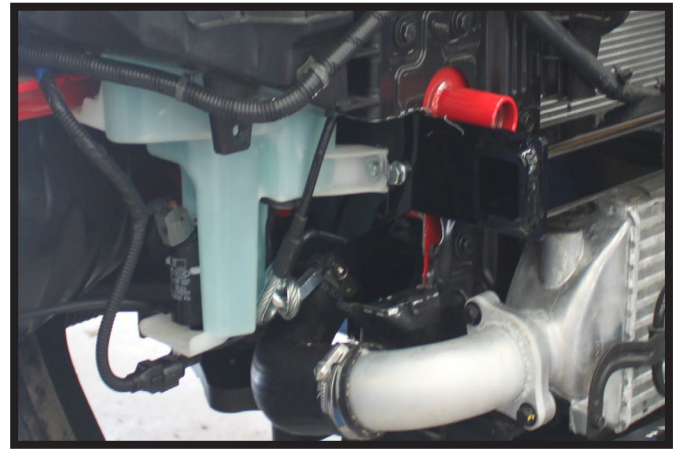

14. Attach the permanent baseplate safety cables to the provided convenience link on the baseplate. The photo above shows the recommended installation of the cables to frame of vehicle. Additional options may interfere with suggested mounting; in this case, secure the cables to a solid piece of the frame as described in the instructions included with the permanent baseplate safety cables. Be sure the safety cables do not rub against any hoses or moving parts. Do this on **BOTH** sides of the vehicle.

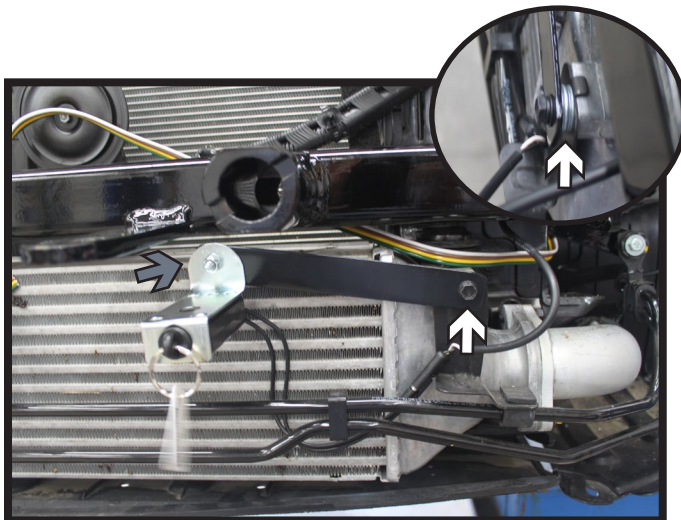

15. Optional Breakaway: Install the bracket to the existing bolt location just to the side of the intercooler (white) with three (3) flat washers behind as a spacer (inset).

Bend the tab of the breakaway up 90° and attach it to the bracket with 1/4"-20 x 3/4 bolt and 1/4"-20 lock nut (gray).

BX2337
2013-2015 Hyundai Genesis Coupe
Installation Instructions

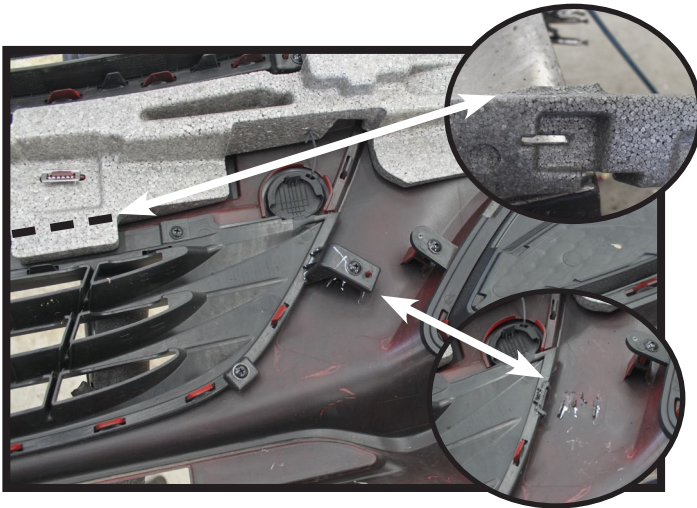

16. On the backside of the fascia, trim the tab off the edge of the grille for baseplate clearance. Also trim the tab off the upper styrofoam support. Do this on both sides of the fascia.



17. Hold the fascia as close to its original position, mark and trim the fascia around the attachment tabs. Reinstall the fascia.

CUSTOMER SERVICE COMMITMENT

Blue Ox® is committed to providing you with exceptional customer care throughout your lifetime with our products. Our team is here to assist you with any questions you may have regarding the performance of your product. Simply call (402) 385-3051 and you can speak with our customer care team.

Additionally, please visit our website to see which rallies our Destination America team will be attending. For a nominal fee, our service technician will service your towing system to ensure it's in proper working condition. Also, as a commitment to our customers, should you visit our factory, you can stay at our full service Blue Ox® campground at no charge along with enjoying a factory tour.

Again, thank you for being our customer and for the confidence you have shown in the performance of our products. It is because of customers like you we enjoy the success we have today.

© 2014 Blue Ox
One Mill Road, Industrial Park
Pender, Nebraska 68047
Phone: (402) 385-3051
Fax: (402) 385-3360
www.blueox.com

General Information

1. Ensure that your product(s) are registered online at www.blueox.com. It is crucial to register your product(s) so that you may be alerted of product offerings, updates, upgrades, maintenance and safety bulletins, and/or recalls.
2. **It is the owner's responsibility to inspect all towing equipment for cracked welds, missing or worn parts and loose bolts before each towing trip.** Be sure to use Loctite® Red on all bolts and tighten to the recommended specifications.
3. **It is the owner's responsibility to hook up all towing equipment per manufacturer's instructions/recommendations.**
4. Remove the attachment tabs when not in use (if applicable).

Notice To Baseplate Installer

1. It is YOUR responsibility to watch for:

- Oil cooler and air conditioner lines
- Electrical wires and hoses
- Missing parts or attaching points on the frame

** If the baseplate is improperly installed and is against a wire or hose, it could cause fluid leaks or electrical shorts some time after the actual baseplate installation.

Permanent Baseplate Safety Cable Installation

Permanent baseplate safety cables are strongly recommended when towing a vehicle with a tow bar. The principle function of the permanent baseplate safety cables is to prevent the towed vehicle from breaking loose in the event the connection between the frame of the towed vehicle and the baseplate fails or becomes disconnected. The cables must be connected from the baseplate to the frame rail or cross member of the vehicle's frame. The illustrations below show the possible arrangements recommended by Blue Ox®. Each permanent baseplate safety cable must have an adequate weight rating for the towing system. The weight rating of the two (2) cables together will not qualify.

Do not mount the permanent baseplate safety cables against wires, hoses or brake lines.

These permanent baseplate safety cables should remain installed as long as the baseplate is installed on the vehicle. Permanent baseplate safety cables are to be used in conjunction with, and NOT a replacement for legally required safety cables attaching the towed vehicle to the towing vehicle.

OPTION #1

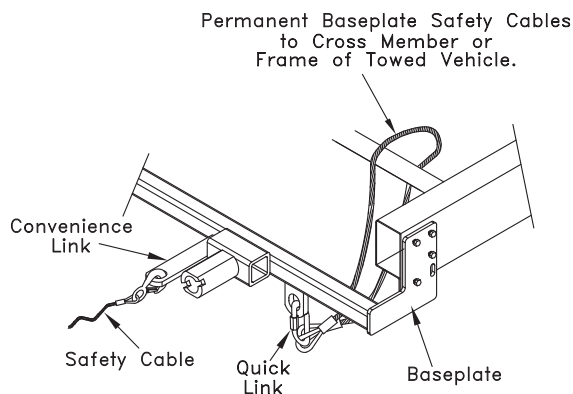

OPTION #2

