



Strong As An Ox™

BX2314 2002 Hyundai Accent Installation Instructions

Serial Number

The front fascia, metal bumper, and blinker assembly is removed for baseplate installation. Holes need to be drilled. The BX8869 is available for the vehicle. Attachment Tabs are 24 inches center to center and a height of 14 inches.



1. Remove the two phillips head push pins from the top side of fascia.



2. There are six phillips head push pins to remove from the bottom side of the fascia.



3. Using the 10MM socket, remove the two metric nuts from fascia support behind fascia and above metal bumper.



4. Just forward of front tires, on fascia corner, remove the phillips head screw. Remove two push pins from upper fascia opening.



5. Remove two metric bolts with the 6MM socket, pull head light assembly forward, unplug, and set aside, both sides.



6. Just under head light assemblies is a push pin to remove, both sides. Pull fascia forward and set aside.



Strong As An Ox™



7. Using the 7MM socket, remove the three metric bolts from the windshield washer reservoir, unplug, and set reservoir aside. Before baseplate can be installed, remove the two push pin brackets from the under side of the metal bumper with the 6MM socket.



9. Using the baseplate as a template, drill the three remaining holes on cross member with the 13/32" drill bit. Insert item 2 into cross member openings to align with drilled holes, install items 6 and 7, and tighten. **Be sure and use loctite on all bolts before tightening. Torque all bolts according to torque chart on General Instruction sheet.**

11. Reinstall fascia and baseplate installation is complete.

12. The dimensional variations between otherwise identical cars can be considerable. While the location and size of the holes in the baseplate were designed to allow for easy installation, it may be necessary to file a hole slightly to allow a bolt to clear.

13. Install the tow bar and safety cables according to the instructions included in their packages.

14. Do not substitute other devices if the tow bar pin and clip are lost.

15. **DEALER OR INSTALLER: BE CERTAIN THE USER RECEIVES THE INSTRUCTION SHEET.**



8. Remove the tow brackets with the 17MM socket, both sides. Hold baseplate to align with these holes and install items 3, 4 and 5, both sides. Tighten all bolts. **Note: Use spacer plate, item 3, as needed, apply equally to each side. Be sure and use loctite on all bolts before tightening. Torque all bolts according to torque chart on General Instructions sheet.**



10. To reinstall windshield washer reservoir, it will be necessary to use spacer tube item 14 and item 15 for the front bolt. The upper bolt location will need to be drilled. Reinstall remaining bolts.



Strong As An Ox™

Tools Required

6MM Socket
7MM Socket
17MM Socket

Loctite Blue
9/16" Socket
Phillips Screw Driver

13/32" Drill Bit
Vise Grips

Parts List

Ref. No.	Qty.	Part No.	Description
1	1	61-5698	Weldment, Base Plate, BX2314
2	3	61-5208	Weldment, 3/8-16, Nut Plate, With Wire
3	6	101-6155	Spacer, Plate, BX2313
4	6	201-0603	12MM-1.25 x 60MM, Hex Bolt, Grd. 8.8, ZP
5	6	203-0105	12MM Lock Washer, ZP
6	3	201-0368	3/8-16 x 1 1/4 Hex Bolt, Grd. 5, ZP
7	3	203-0010	3/8 Lock Washer, ZP
8	2	201-0979	#12-14 x 1" Self Drilling Screw, ZP
9	2	202-0047	#10-32 Hex Nut
10	2	203-0054	#10 Lock Washer
11	2	201-0192	#10-32 x 1/2 Slot, Rd. Hd. Screw
12	2	101-5822	Adapter, 4 Way Connector
	1	107-2447	Tube, 1/2 OD x 18GA x 1.0 (Not Shown)
	1	201-0702	6MM-1.00 x 45MM, Hex Bolt, Grd 8.8(Not Shown)



SOME MODELS MAY
REQUIRER SPACER PLATES
APPLY EQUALLY TO EACH SIDE.

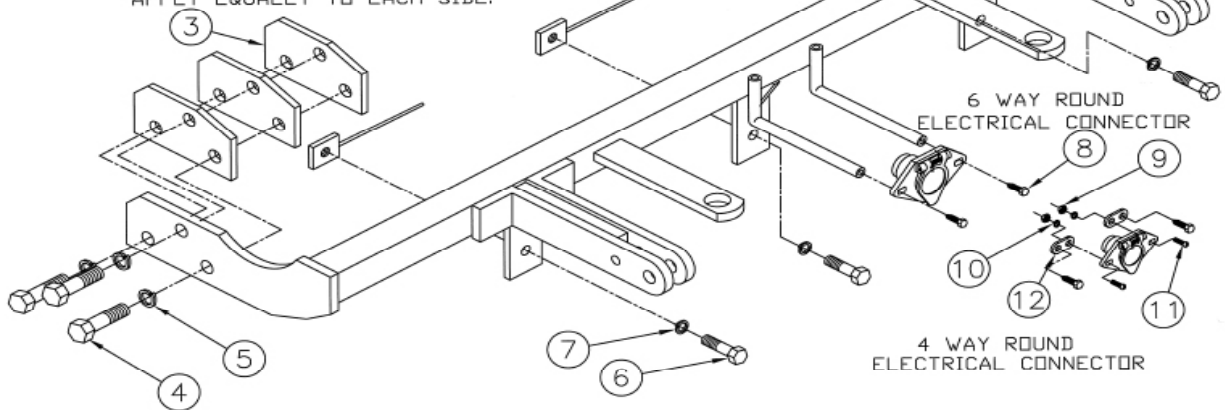

Parts Not Pictured:

Qty.	Part #	Description
2	226-0046	Baseplate Safety Cables
2	229-0359	Quicklink, 3/8, ZP

IMPORTANT: Use only genuine factory replacement parts on your Base Plate. Do not substitute homemade or nontypical parts. If a bolt is lost or in need of replacement, for your safety and the preservation of your Base Plate, be sure to use a replacement bolt of the same grade (Usually Grade 5, refer to parts list). Repair parts may be ordered through your nearest **Blue Ox** dealer or distributor.

General Information

1. Ensure that your product(s) are registered online at www.blueox.com. It is crucial to register your product(s) so that you may be alerted of product offerings, updates, upgrades, maintenance and safety bulletins, and/or recalls.
2. **It is the owner's responsibility to inspect all towing equipment for cracked welds, missing or worn parts and loose bolts before each towing trip.** Be sure to use Loctite® Red on all bolts and tighten to the recommended specifications.
3. **It is the owner's responsibility to hook up all towing equipment per manufacturer's instructions/recommendations.**
4. Remove the attachment tabs when not in use (if applicable).

Notice To Baseplate Installer

1. It is YOUR responsibility to watch for:

- Oil cooler and air conditioner lines
- Electrical wires and hoses
- Missing parts or attaching points on the frame

** If the baseplate is improperly installed and is against a wire or hose, it could cause fluid leaks or electrical shorts some time after the actual baseplate installation.

Permanent Baseplate Safety Cable Installation

Permanent baseplate safety cables are strongly recommended when towing a vehicle with a tow bar. The principle function of the permanent baseplate safety cables is to prevent the towed vehicle from breaking loose in the event the connection between the frame of the towed vehicle and the baseplate fails or becomes disconnected. The cables must be connected from the baseplate to the frame rail or cross member of the vehicle's frame. The illustrations below show the possible arrangements recommended by Blue Ox®. Each permanent baseplate safety cable must have an adequate weight rating for the towing system. The weight rating of the two (2) cables together will not qualify.

Do not mount the permanent baseplate safety cables against wires, hoses or brake lines.

These permanent baseplate safety cables should remain installed as long as the baseplate is installed on the vehicle. Permanent baseplate safety cables are to be used in conjunction with, and NOT a replacement for legally required safety cables attaching the towed vehicle to the towing vehicle.

OPTION #1

Permanent Baseplate Safety Cables to Cross Member or Frame of Towed Vehicle.

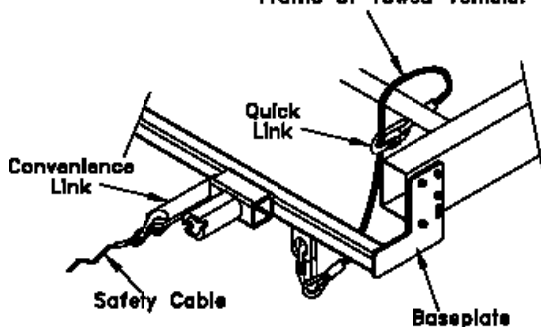

OPTION #2

Permanent Baseplate Safety Cables to Cross Member or Frame of Towed Vehicle.

