



Strong As An Ox™

BX2217 Installation Instructions 1996-00 Honda Civic (Not CX)

Utilization of Blue Ox baseplates with any other tow bar not approved by Automatic Equipment Mfg. Company invalidates the limited warranty.

Installation of this baseplate requires removing the plastic belly pan and the tie down brackets of the vehicle.

1. Read the General Instruction Sheet included with this baseplate.
2. The baseplate attaches to the tie down mounts using six bolts supplied with the baseplate.
3. Remove the plastic belly pan right behind the front bumper. Three bolts and six plastic bolt/rivets hold the pan on.
4. Remove the six bolts (three on each side) which hold the tie down brackets on the car. Set the bolts and brackets aside, they will not be used to install the baseplate.
5. With help, hold the baseplate between the frames, align the holes in the baseplate with the holes the tie down brackets were mounted in. Apply Locktite to bolts. Start the supplied 10mm x 30mm bolts and lock washers.
6. Snug up the bolts. Before final tightening, push up on the front of the baseplate. The baseplate should fit as close as possible to the bottom of the bumper. Tighten all six bolts securely.
7. Replace the belly pan. The slots for the tie down brackets will have to be enlarged to accommodate the baseplate.
8. Included in the manual package is a dash decal for your car to remind you how to set up the transmission to tow. Place the decal on the dash of your Honda or on the tow bar or anywhere it will remind you to make sure your transmission will be properly shifted before you tow. Detailed instructions appear later in this instruction sheet.
9. The dimensional variations between otherwise identical cars can be considerable. While the location and size of the holes in the baseplate were designed to allow easy installation, it may be necessary to file a hole slightly to allow a bolt to clear.
10. Install the tow bar and safety cables according to the instructions included in their packages.
11. Do not substitute other devices if the tow bar pin and clip are lost.
12. **DEALER OR INSTALLER: BE CERTAIN THE USER RECEIVES THE INSTRUCTION SHEET.**

1989 & Newer Honda Automatics

All Honda and Acura automatic transmission vehicles, any model, any year, can be towed without special pumps or drive shaft disconnects. Please note however that Honda and Acura automatic transmissions for 1989 & newer were modified so they cannot be shifted rapidly from reverse to drive. Rapid shifting from reverse to drive can damage any automatic transmission.

Honda advises that the modification leaves a portion of the automatic transmission in reverse when it is only shifted from reverse to neutral. This partial neutral condition cannot be detected by revving the engine, because the car will not move even though a portion of the transmission is still in reverse. If the car is towed on all four wheels in this false-neutral condition, the automatic transmission will be damaged.

To make sure that the automatic transmission is completely in neutral, it must be shifted to drive and then to neutral before turning the engine off and towing the car on all four wheels. In other words, a 1989 and newer model Honda or Acura car equipped with an automatic transmission can be towed on all four wheels without damaging the transmission, if the transmission lever is shifted from the drive position to the neutral position before the engine is turned off. If the transmission lever is shifted from the reverse position to the neutral position, the automatic transmission will be damaged when the car is towed on all four wheels.

Tools Required

10mm Socket	14mm Socket	14mm Combination Wrench
Utility Knife or Tin Snips	17mm Socket	17mm Combination Wrench
Loctite Blue		

Parts List

Ref. No.	Qty.	Part No.	Description
1	6	203-0104	10mm Lock Washer
2	6	201-0422	10mm-1.25 x 30mm Hex Bolt, Grade 8.8
3	1	61-4745	Weldment, Baseplate, BX2217
	1	292-2127	Decal, Honda Transmission Set-up (Not Shown)
	2	226-0046	Baseplate Safety Cable, 36" CL III (Not Shown)
	4	229-0359	Quicklink, 3/8, ZP (Not Shown)

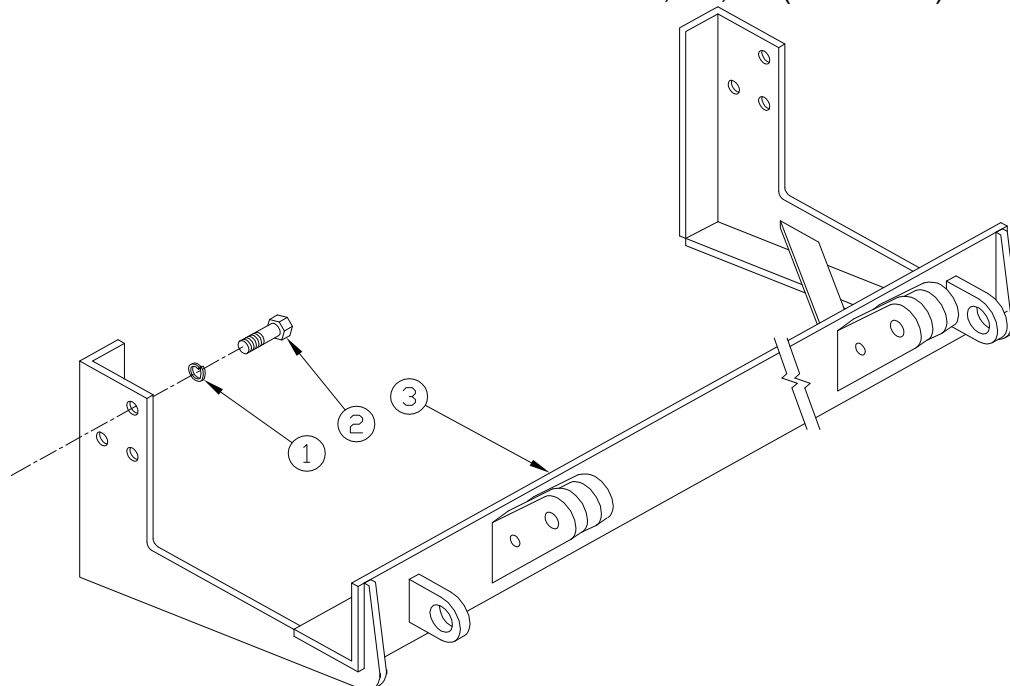

General Information

1. Ensure that your product(s) are registered online at www.blueox.com. It is crucial to register your product(s) so that you may be alerted of product offerings, updates, upgrades, maintenance and safety bulletins, and/or recalls.
2. **It is the owner's responsibility to inspect all towing equipment for cracked welds, missing or worn parts and loose bolts before each towing trip.** Be sure to use Loctite® Red on all bolts and tighten to the recommended specifications.
3. **It is the owner's responsibility to hook up all towing equipment per manufacturer's instructions/recommendations.**
4. Remove the attachment tabs when not in use (if applicable).

Notice To Baseplate Installer

1. It is YOUR responsibility to watch for:

- Oil cooler and air conditioner lines
- Electrical wires and hoses
- Missing parts or attaching points on the frame

** If the baseplate is improperly installed and is against a wire or hose, it could cause fluid leaks or electrical shorts some time after the actual baseplate installation.

Permanent Baseplate Safety Cable Installation

Permanent baseplate safety cables are strongly recommended when towing a vehicle with a tow bar. The principle function of the permanent baseplate safety cables is to prevent the towed vehicle from breaking loose in the event the connection between the frame of the towed vehicle and the baseplate fails or becomes disconnected. The cables must be connected from the baseplate to the frame rail or cross member of the vehicle's frame. The illustrations below show the possible arrangements recommended by Blue Ox®. Each permanent baseplate safety cable must have an adequate weight rating for the towing system. The weight rating of the two (2) cables together will not qualify.

Do not mount the permanent baseplate safety cables against wires, hoses or brake lines.

These permanent baseplate safety cables should remain installed as long as the baseplate is installed on the vehicle. Permanent baseplate safety cables are to be used in conjunction with, and NOT a replacement for legally required safety cables attaching the towed vehicle to the towing vehicle.

OPTION #1

Permanent Baseplate Safety Cables to Cross Member or Frame of Towed Vehicle.

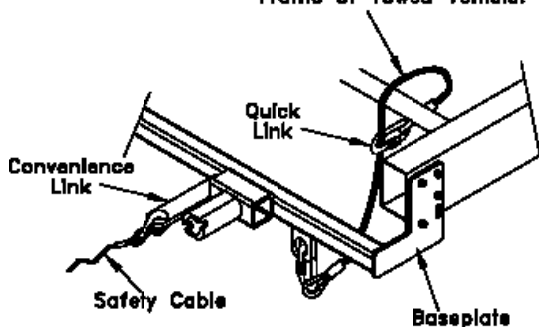

OPTION #2

Permanent Baseplate Safety Cables to Cross Member or Frame of Towed Vehicle.

