



BX2187

2007-11 Ford Ranger (2WD) Installation Instructions

Serial Number

Please read BOTH these Installation Instructions and the General Towing Instructions before attempting to install or operate this equipment.

- Blue Ox® towing products and accessories are intended to be installed by Blue Ox® Dealers who are familiar with our products and have the equipment and knowledge to do “fit work”. When necessary, Blue Ox® Dealers can be found at www.blueox.com or by contacting our Customer Care Department at (402) 385-3051.
- Many Blue Ox® baseplates are designed to use existing holes and hardware to mount the baseplate to the towed vehicle. Even though bolts are there, do not assume they are adequate for baseplate mounting. Always use hardware supplied in the hardware kit or existing hardware specified in the Baseplate Installation Instructions.

Attachment Tab Height: 18-1/2”
Attachment Tab Width: 18”

Bolt Torque Specifications
Torque in Foot-Pounds for Metric Bolts

Bolt Size	Grade 8.8	Grade 10.9
6MM	6	8
8MM	16	22
10MM	31	40
12MM	54	70
14MM	89	117

Confirm the towability and pre-towing procedures for your vehicle with the owner’s manual or contact the vehicle’s manufacturer for specific towing procedures.

Bolt Torque Specifications
Torque in Foot-Pounds for Inch Bolts

Bolt Size	Grade 5	Grade 8
1/4”	10	14
5/16”	19	29
3/8”	33	47
7/16”	54	78
1/2”	78	119
5/8”	154	230



If the front of your vehicle looks different than these, call us at (402) 385-3051.

WARNING

Failure to read and follow these instructions could result in separation of the towed vehicle from the tow bar, causing property damage, loss of towed vehicle, personal injury or death.

BX2187
2007-11 Ford Ranger (2WD)
Installation Instructions

Parts List

Ref. No.	Qty.	Part #	Description
1	1	61-6318	Weldment, Base Plate, BX2187
2	4	61-5338	1/2-13 Nut Plate, with 10" Wire
3	4	61-4029	1/2-13 Whiz Nut, with 10" Wire
4	8	201-0068	1/2-13 x 1 3/4" Hex Bolt, ZP
5	8	203-0012	1/2" Lock Washer, ZP
6	4	203-0005	1/2" Flat Washer, ZP
7	2	101-5147	Plate Washer, 1/2" Hole, ZP
8	2	201-0979	#12-14 x 1" Self Drilling Screw, ZP
9	2	201-0192	#10-32 x 1/2 Slot, Rd. Hd. Screw
10	2	203-0054	#10 Lock Washer, ZP
11	2	202-0047	#10-32 Hex Nut, ZP
12	2	101-5822	Adapter, 4 Way Connector
13	2	62-3469	Attachment, Assembly, SF/LB (R)
	2	290-0437	Cap Plug, Black (Not Shown)
	2	226-0046	Permanent Baseplate Safety Cables, CLIII (Not Shown)
	2	229-0359	3/8" Quick Link, ZP (Not Shown)
	*2	201-0050	1/4-20 x 3/4" Hex Bolt, Grd. 5, ZP (Not Shown)
	*2	203-0008	1/4" Flat Washer, ZP (Not Shown)
	*2	203-0001	1/4" Lock Washer, ZP (Not Shown)
	*2	202-0001	1/4-20 Hex Nut, ZP (Not Shown)

*If applicable, these items used for installation of electrical connector for vehicles with front-mount license plates.

Tools Required

- Loctite® RED
- 18MM Socket
- 7/16" Socket
- 3/4" Socket
- 17/32" Drill Bit
- Vise Grips
- Hammer
- *1" Hole Saw
- *9/32" Drill Bit

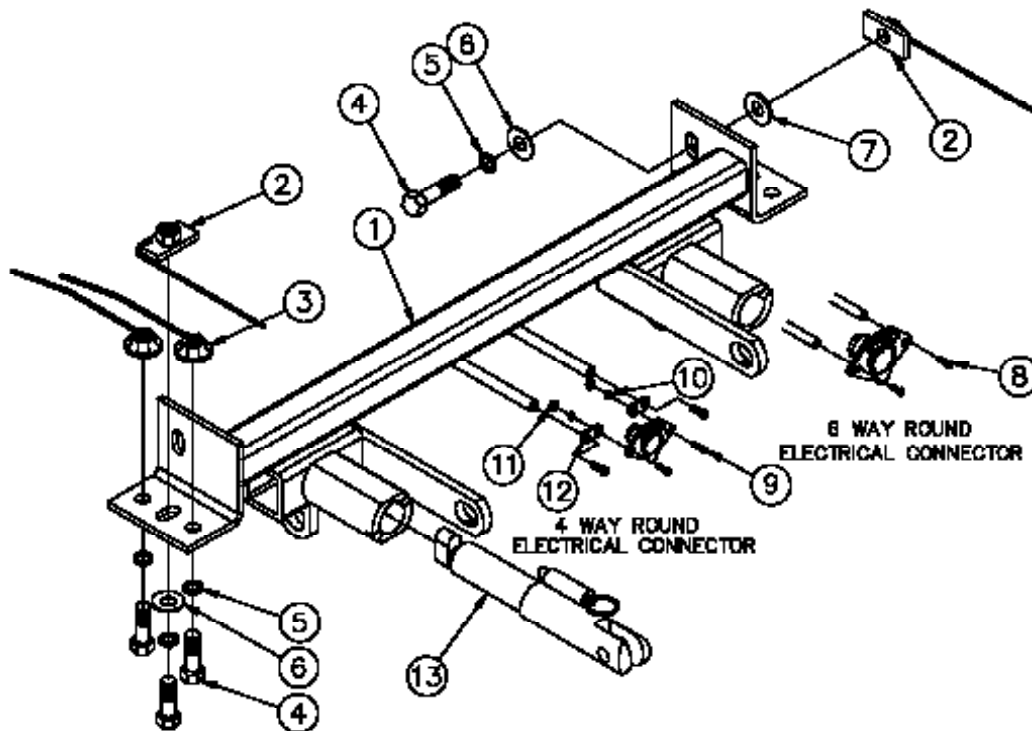

Important:

Use only genuine factory replacement parts on your baseplate. Do **NOT** substitute homemade or non-typical parts. If a bolt is lost or in need of replacement, for your safety and the preservation of your baseplate, be sure to use a replacement bolt of the same grade (In most cases it will be Grade 5, please reference the parts list above). Replacement parts may be ordered through your nearest Blue Ox® Dealer or Distributor. Failing to follow and/or altering these installation instructions in either installation or required equipment will void the manufacturer's warranty.

BX2187
2007-11 Ford Ranger (2WD)
Installation Instructions

Attachment Tabs:

Due to the design of removable tabs, the RangeFinder II, Acclaim, Adventurer and Ambassador tow bars can not be used. Adapters, except the BX8833 and BX88151, can not be used with this baseplate.

Installation Notes: The metal bumper is removed for installation. Drilling is required.

The dimensional variations between otherwise identical vehicles can be considerable. While the baseplate was designed for easy installation, it may be necessary to tailor the baseplate slightly to compensate for auto manufacturer's tolerances. These minor adjustments may include filing a hole slightly, bending electrical rods or bending end plates.

The BX8869 Bulb and Socket Wiring Kit is recommended for this vehicle.

Installation Instructions

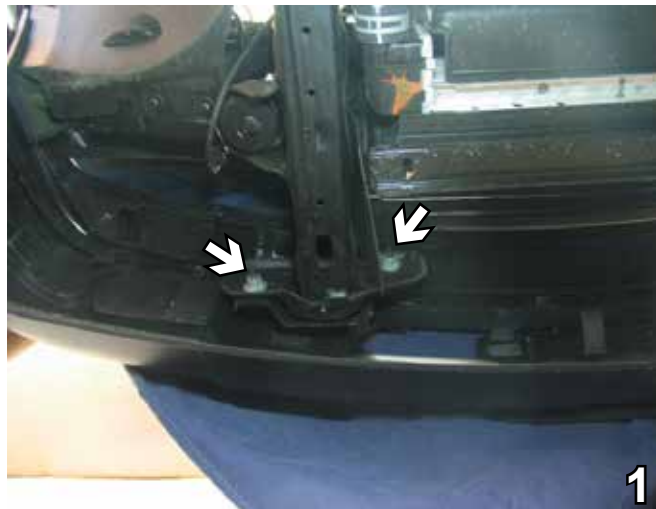

1. Using the 18MM socket, remove two (2) metric bolts from the back of the metal bumper. Do this to both sides of the vehicle. Pull bumper forward to remove. Set bolts and bumper aside to be reinstalled later.

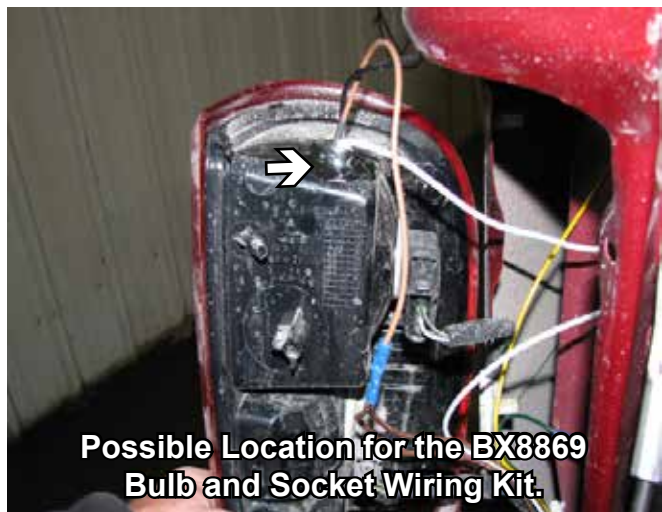

2. Underneath, in front of the frame, use a hack saw blade to cut 3/8" off of the plastic shield for the radiator. Get as close to the flat washer as possible. Do this on both sides of the vehicle.

Handling of some cosmetic parts when installing this product may require the use of protective covers, rags, specialty tools, etc. to prevent damage.

BX2187
2007-11 Ford Ranger (2WD)
Installation Instructions

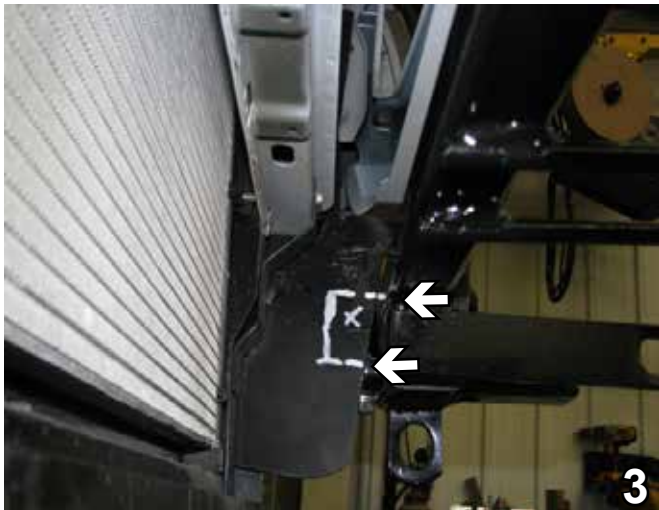

3. Holding the baseplate up to the air dam mark the area width and depth, about 1-1/2", that needs to be removed. Cut out the area, snap the lower push pin in place. Do this to both sides of the vehicle.



4. Align baseplate to existing holes on bottom and inside of frame rail. Using the vise grips, clamp into place. Do this to both sides of the vehicle.

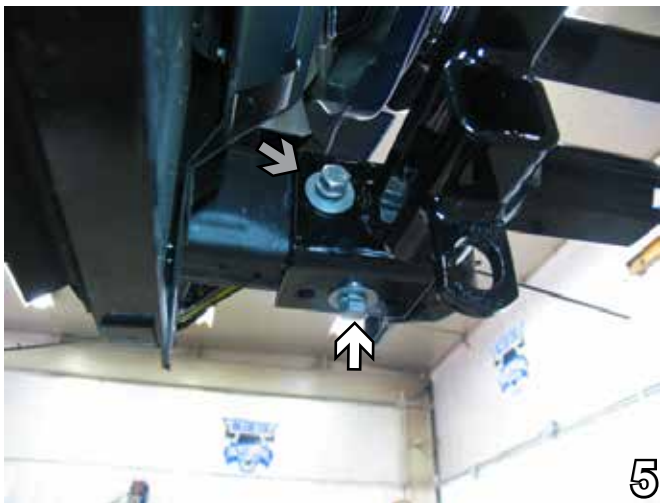

5. Insert 1/2"-13 nut plates through frame end hole and align to existing holes. In bottom hole, (see white arrow) install 1/2"-13 x 1-3/4" hex bolt with 1/2" flat washer and 1/2" lock washer and tighten. In the top hole (see grey arrow), install 1/2"-13 x 1-3/4" hex bolt with 1/2" lock washer and 1/2" plate washer and tighten. Trim excess nut plate wire. Do this to both sides of the vehicle.

BX2187
2007-11 Ford Ranger (2WD)
Installation Instructions

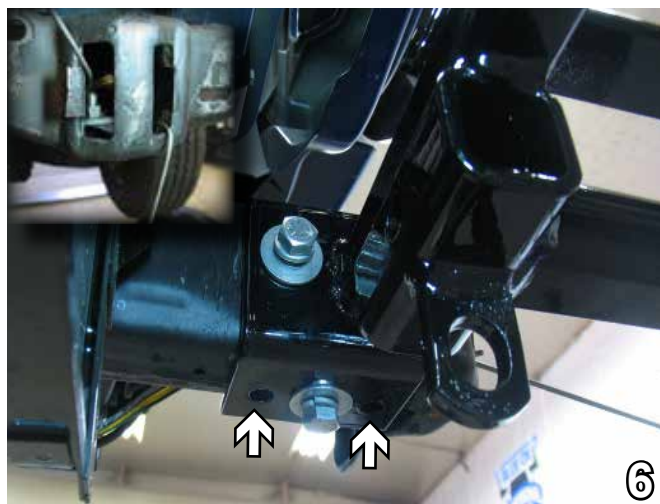

6. Using the baseplate as a template, drill the remaining two (2) holes into the bottom of the frame rail using the 17/32" drill bit. *Note: A smaller drill bit may be used to start the pilot hole.* Insert 1/2"-13 whiz nuts through frame end hole and align to drilled holes. Install 1/2"-13 x 1 3/4" hex bolts with 1/2" flat washers and 1/2" lock washers and tighten. Do this to both sides of the vehicle. Insure nut plates are placed lengthwise across frame (see inset) so they do not block other holes.

When using power drills be aware of the dangers of torque and drill bit length.

BE SURE TO USE LOCTITE® RED ON ALL BOLTS BEFORE TIGHTENING. TIGHTEN ALL BOLTS ACCORDING TO THE TORQUE CHART ON THE FRONT PAGE OF THESE INSTRUCTIONS OR ON PAGE 3 OF THE BASEPLATE TOWING GENERAL INSTRUCTIONS.

Note: *If the vehicle has a front-mount license plate, the electrical connector may need to be relocated. There are two options:*

- (1) *Steps 9 - 11 (moving license plate front mount)*
- (2) *Step 12 (Relocate electrical connector)*

7. Reinstall metal bumper and bolts.



8. Attach the permanent baseplate safety cables to the provided convenience link on the baseplate (see grey arrow). The photo above shows the recommended installation of the cables to frame of vehicle (see white arrow). Additional options may interfere with suggested mounting; in this case secure the cables to a solid piece of the frame as described in the instructions included with the permanent baseplate safety cables. Be sure the safety cables do not rub against any hoses or moving parts. Do this to both sides of the vehicle.



9. If the vehicle has a front-mount license plate, lay the fascia face down. Remove two (2) push pins from the top opening.

BX2187
2007-11 Ford Ranger (2WD)
Installation Instructions

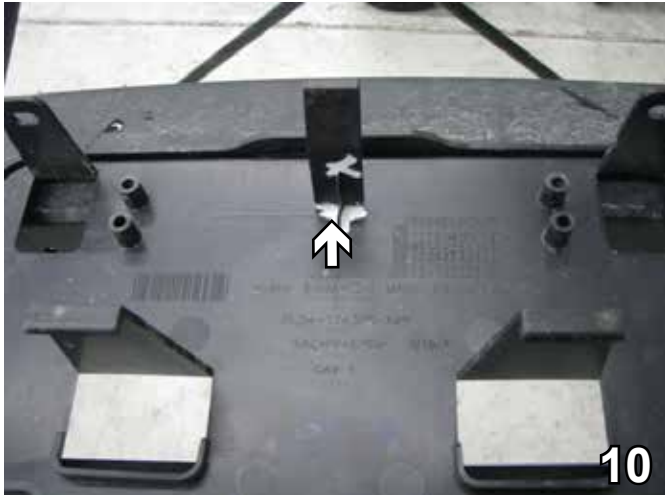

10. Turn the fascia over so that the front is up, lift off the license bracket. Turn the license bracket over. Cut off the single tube in the middle using a hack saw blade.



11. Turn the license plate bracket upside down. Reattach to the bracket, using 1-3/8" self tapping screws. The bottom holes are used to attach the license plate.



12. Using a 1" hole saw, drill a hole through the bottom of the fascia (see white arrow). Insert electrical connector. Using the electrical connector as a template, drill two (2) holes into the fascia using the 9/32" drill bit. Install 1/4"-20 x 3/4" hex bolt with 1/4" flat washer and 1/4" lock washer and 1/4"-20 hex nut and tighten.

DEALER or INSTALLER:
Be certain the user receives the instruction sheets for their products.

Install the tow bar and safety cables according to the instructions provided in their packages. When demonstrating this to the customer, be sure to include all the contents and packages.

Do **NOT** substitute other devices if the tow bar pins and clips are misplaced.

BX2187
2007-11 Ford Ranger (2WD)
Installation Instructions



Shown without removable tabs installed.



Shown with removable tabs installed.

If the baseplate is in an accident, it must be replaced. DO NOT use it again! An accident can cause unseen damage and using it again could result in more damage or serious injury. DO NOT use the baseplate if it is damaged or missing parts.

CUSTOMER SERVICE COMMITMENT

Blue Ox is committed to providing you with exceptional customer care throughout your lifetime with our products. Our team is here to assist you with any questions you may have regarding the performance of your product. Simply call 1-402-385-3051 and you can speak with our customer care team.

Additionally, please visit our website to see which rallies our Destination America team will be attending. For a nominal fee, our service technician will service your towing system to ensure it's in proper working condition. Also, as a commitment to our customers, should you visit our factory you can stay at our full service Blue Ox campground at no charge along with enjoying a factory tour.

Again, thank you for being our customer and for the confidence you have shown in the performance of our products. It is because of customers like you we enjoy the success we have today.



General Information

1. Ensure that your product(s) are registered online at www.blueox.com. It is crucial to register your product(s) so that you may be alerted of product offerings, updates, upgrades, maintenance and safety bulletins, and/or recalls.
2. **It is the owner's responsibility to inspect all towing equipment for cracked welds, missing or worn parts and loose bolts before each towing trip.** Be sure to use Loctite® Red on all bolts and tighten to the recommended specifications.
3. **It is the owner's responsibility to hook up all towing equipment per manufacturer's instructions/recommendations.**
4. Remove the attachment tabs when not in use (if applicable).

Notice To Baseplate Installer

1. It is YOUR responsibility to watch for:

- Oil cooler and air conditioner lines
- Electrical wires and hoses
- Missing parts or attaching points on the frame

** If the baseplate is improperly installed and is against a wire or hose, it could cause fluid leaks or electrical shorts some time after the actual baseplate installation.

Permanent Baseplate Safety Cable Installation

Permanent baseplate safety cables are strongly recommended when towing a vehicle with a tow bar. The principle function of the permanent baseplate safety cables is to prevent the towed vehicle from breaking loose in the event the connection between the frame of the towed vehicle and the baseplate fails or becomes disconnected. The cables must be connected from the baseplate to the frame rail or cross member of the vehicle's frame. The illustrations below show the possible arrangements recommended by Blue Ox®. Each permanent baseplate safety cable must have an adequate weight rating for the towing system. The weight rating of the two (2) cables together will not qualify.

Do not mount the permanent baseplate safety cables against wires, hoses or brake lines.

These permanent baseplate safety cables should remain installed as long as the baseplate is installed on the vehicle. Permanent baseplate safety cables are to be used in conjunction with, and NOT a replacement for legally required safety cables attaching the towed vehicle to the towing vehicle.

OPTION #1

Permanent Baseplate Safety Cables to Cross Member or Frame of Towed Vehicle.

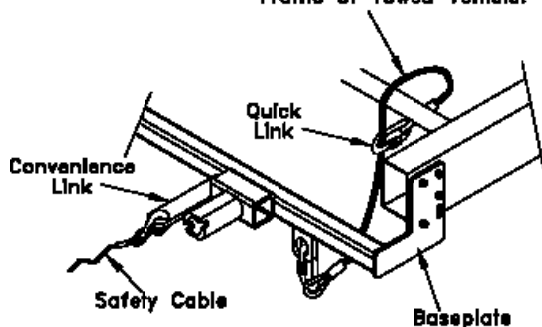

OPTION #2

Permanent Baseplate Safety Cables to Cross Member or Frame of Towed Vehicle.

