



**BX2171 Installation Instructions
2004-07 Ford Freestar**

Serial No.

Strong As An Ox™ The headlight assembly, front fascia, horn bracket and windshield washer reservoir are removed for baseplate installation. Drilling is required. Trimming of fascia and frame is required. The BX8869 is available for the vehicle. Attachment Tabs are 24 inches center to center and a height of 14 inches.



1. Remove the eight push pins from black plastic cover on top side of fascia, lift cover and set aside.



2. Pull the two clips straight up just behind headlight assembly, pull forward, unplug electrical and set aside, both sides.



3. Remove the eight push pins from the top side of fascia.



4. Just behind headlight assembly inside fender and fascia's corner are two metric bolts to remove with the 7MM socket, both sides.



5. Remove the two phillips screw just forward of the front tire, on fascia and wheel well edge with the phillips screw driver, both sides.



6. Just forward of front tires and on fascia's lower edge are nine phillips screws to remove with the phillips screw driver, both sides.



Strong As An Ox™



7. Push retainer clip down to release front fascia just below headlight assembly on both sides, pull forward, disconnect electrical and set aside.

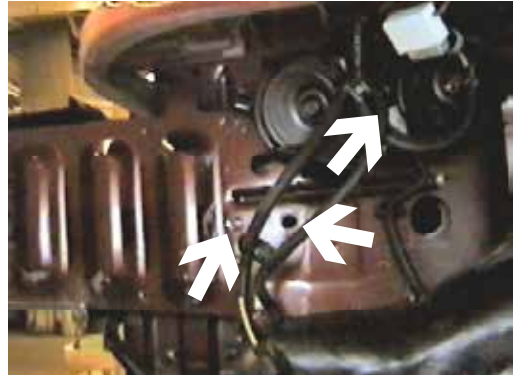

8. Remove one metric bolt from driver's side horn bracket using the 8MM socket, disconnect or pull up out of the way (Top white arrow).



9. Using the 8MM socket, remove one metric bolt from forward windshield washer reservoir.



10. Just behind headlight assembly is one metric bolt to remove from washer reservoir with the 8MM socket.



11. Remove the metric bolt just under radiator reservoir and behind headlight assembly with the 8MM socket, disconnect electrical and fluid hoses, set aside.



12. Cut and remove webbing flush with the side of frame rail just behind metal bumper with the hack saw or reciprocating saw, both sides, as shown in photo.



Strong As An Ox™

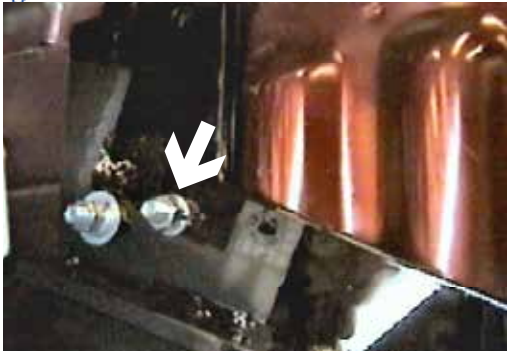

13. Insert the two bolt plates into hole on the side of frame rail, to align with existing holes (See lower arrows in photo of step 8) and align lower holes of spacer plate, both sides. Slide baseplate into place to align with mating spacer plate holes and insert bolt plates through baseplate. While maintaining a level position with removable attachment tabs, tighten 3/8" hex nut, flat washer and lock washer, according to drawing on page 4, both sides. **Be sure to use loctite red on all bolts before tightening. Tighten all bolts according to Torque Chart in General Instruction Sheet.**

15. Using the 9/32" drill bit, drill out the front mount hole for washer reservoir, located on the upper frame webbing just forward of baseplate. Reinstall the two bolts just below radiator reservoir for the washer reservoir. Insert 1/4" hex bolt into 1/4" flat washer, forward washer reservoir hole, 1/4" flat washer, spacer tube, drilled hole, 1/4" flat washer, tighten lock washer and hex nut. **Be sure and use loctite red on all bolts before tightening. Torque all bolts according to torque chart in General Instructions.**

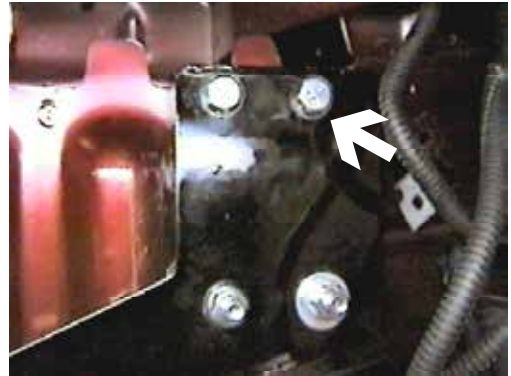

14. Using the baseplate as a template drill two remaining holes into webbing on the top edge of frame with the 13/32" drill bit, both sides. Insert 3/8" hex bolts into baseplate and drilled holes. Tighten 3/8" hex nuts and lock washers according to drawing on last page, both sides. **Be sure and use loctite red on all bolts before tightening. Tighten all bolts according to Torque Chart in General Instruction Sheet.**



16. Hold fascia to its original position, trim as needed. Reinstall horn bracket, fascia and headlight assemblies. **Be sure all electrical components and fluid hoses are plugged in properly.**

17. The dimensional variations between otherwise identical cars can be considerable. While the baseplate was designed for easy installation, it may be necessary to tailor the baseplate slightly to compensate for auto manufacturers' tolerances. These minor adjustments may include filing a hole slightly, bending electrical rods, adding shims and/ or bending endplates.

18. Install the tow bar and safety cables according to the instructions included in their packages.

19. Do **not** substitute other devices if the tow bar pin and clip are lost.

20. **DEALER OR INSTALLER: BE CERTAIN THE USER RECEIVES THE INSTRUCTION SHEET.**



Strong As An Ox™

Tools Required

8MM Socket
9/32" Drill Bit
Phillips Screw Driver

7/16" Socket
Loctite Red
Utility Knife

9/16" Socket
13/32" Drill Bit
Hack Saw or Reciprocating Saw

Parts List

Ref. No.	Qty.	Part No.	Description
1	1	61-5985	Weldment, Base Plate, BX2171
2	2	61-5987	Weldment, Spacer Plate BX2171
3	4	61-5988	Weldment, 3/8-16 Bolt Plate, w/ 14" Wire
4	1	106-0369	Pipe, 3/8" Sch 40 x 1 1/2"
5	4	201-0444	3/8-16 x 2 Hex Bolt, Grd. 5, ZP
6	2	203-0003	3/8" Flat Washer, ZP
7	8	203-0010	3/8" Lock Washer, ZP
8	8	202-0003	3/8-16 Hex Nut, ZP
9	1	201-0321	1/4-20 x 2 1/2" Hex Bolt, Grd. 5, ZP
10	4	203-0001	1/4" Flat Washer, ZP
11	1	203-0008	1/4" Lock Washer, ZP
12	1	202-0001	1/4-20 Hex Nut, ZP
13	2	201-0979	#12-14 x 1" Self Drilling Screw, ZP
14	2	201-0192	#10-32 x 1/2 Slot, Rd. Hd. Screw, ZP
15	2	203-0054	#10 Lock Washer, ZP
16	2	202-0047	#10-32 Hex Nut, ZP
17	2	101-5822	Adapter, 4 Way Connector, ZP
18	2	62-3468	Attachment, Assembly, SF/ SB (R)
	2	226-0046	Baseplate Safety Cable, 36" CL III (Not Shown)
	2	229-0359	Quicklink, 3/8, ZP (Not Shown)
	2	290-0437	Receiver, Cap Plug (Blk) (Not Shown)



Location for the Bx8869 on driver's side tail light assembly.

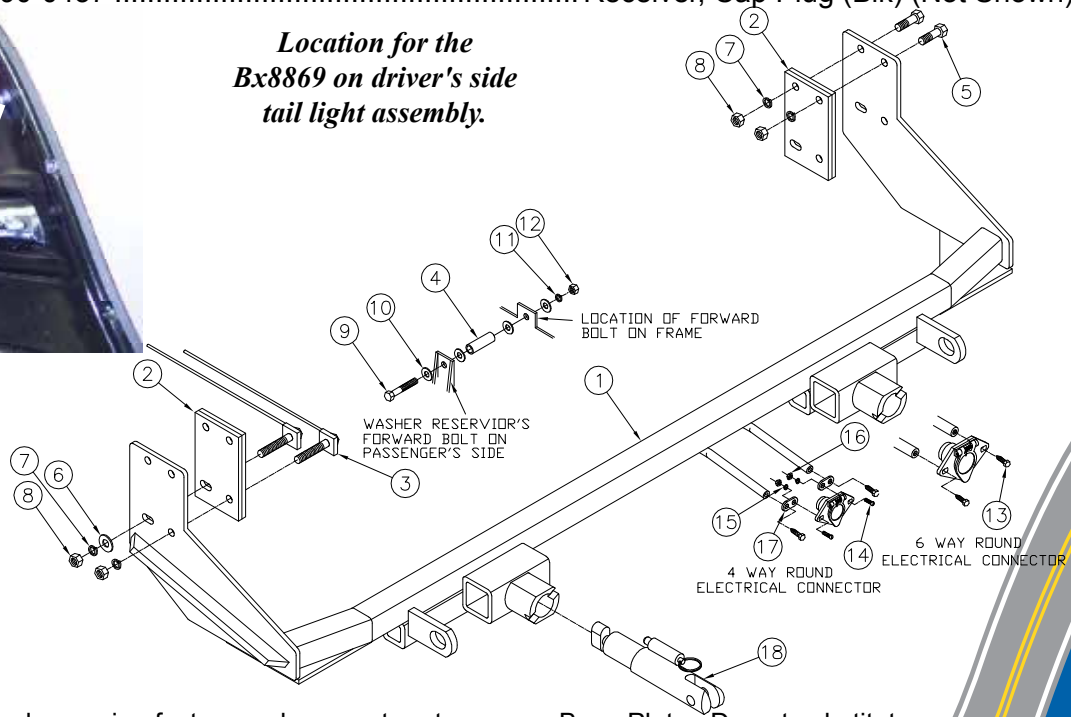

IMPORTANT: Use only genuine factory replacement parts on your Base Plate. Do not substitute homemade or nontypical parts. If a bolt is lost or in need of replacement, for your safety and the preservation of your Base Plate, be sure to use a replacement bolt of the same grade (Usually Grade 5, refer to parts list). Repair parts may be ordered through your nearest **Blue Ox** dealer or distributor.

General Information

1. Ensure that your product(s) are registered online at www.blueox.com. It is crucial to register your product(s) so that you may be alerted of product offerings, updates, upgrades, maintenance and safety bulletins, and/or recalls.
2. **It is the owner's responsibility to inspect all towing equipment for cracked welds, missing or worn parts and loose bolts before each towing trip.** Be sure to use Loctite® Red on all bolts and tighten to the recommended specifications.
3. **It is the owner's responsibility to hook up all towing equipment per manufacturer's instructions/recommendations.**
4. Remove the attachment tabs when not in use (if applicable).

Notice To Baseplate Installer

1. It is YOUR responsibility to watch for:

- Oil cooler and air conditioner lines
- Electrical wires and hoses
- Missing parts or attaching points on the frame

** If the baseplate is improperly installed and is against a wire or hose, it could cause fluid leaks or electrical shorts some time after the actual baseplate installation.

Permanent Baseplate Safety Cable Installation

Permanent baseplate safety cables are strongly recommended when towing a vehicle with a tow bar. The principle function of the permanent baseplate safety cables is to prevent the towed vehicle from breaking loose in the event the connection between the frame of the towed vehicle and the baseplate fails or becomes disconnected. The cables must be connected from the baseplate to the frame rail or cross member of the vehicle's frame. The illustrations below show the possible arrangements recommended by Blue Ox®. Each permanent baseplate safety cable must have an adequate weight rating for the towing system. The weight rating of the two (2) cables together will not qualify.

Do not mount the permanent baseplate safety cables against wires, hoses or brake lines.

These permanent baseplate safety cables should remain installed as long as the baseplate is installed on the vehicle. Permanent baseplate safety cables are to be used in conjunction with, and NOT a replacement for legally required safety cables attaching the towed vehicle to the towing vehicle.

OPTION #1

Permanent Baseplate Safety Cables to Cross Member or Frame of Towed Vehicle.

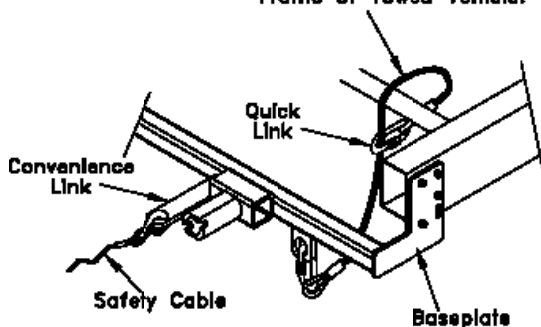

OPTION #2

Permanent Baseplate Safety Cables to Cross Member or Frame of Towed Vehicle.

