



## BX1999

### 2011-2012 Mitsubishi Eclipse Spyder Installation Instructions

**Attachment Tab Height: 14.5"**

**Attachment Tab Width: 30"**

**Serial Number**

**Please read BOTH these Installation Instructions and the General Information sheet prior to installing or operating this equipment.**

1. Blue Ox® towing products and accessories are intended to be installed by Blue Ox® Dealers who are familiar with our products and have the equipment and knowledge necessary to do "fit work". If needed, Blue Ox® Dealers can be found at [www.blueox.com](http://www.blueox.com) or by contacting our Technical Service Department at (402) 385-3051.
2. Many Blue Ox® baseplates are designed to use existing holes and hardware to mount the baseplate to the towed vehicle. Even though bolts are there, do not assume they are adequate for baseplate mounting. Always use the hardware supplied in the hardware kit and existing hardware as specified in the installation instructions.

#### Bolt Torque Specifications

Torque in Foot-Pounds for Inch Bolts

Bolt Size	Grade 5	Grade 8
1/4"	10	14
5/16"	19	29
3/8"	33	47
7/16"	54	78
1/2"	78	119
5/8"	154	230
3/4"	257	380

#### Bolt Torque Specifications

Torque in Foot-Pounds for Metric Bolts

Bolt Size	Grade 8.8	Grade 10.9
6MM	6	8
8MM	16	22
10MM	31	40
12MM	54	70
14MM	89	117
16MM	161	230
18MM	222	318



**If the front of your vehicle looks different than this, call us at (402) 385-3051.**

**Reference your vehicle owner's manual for manufacturer's towing specifications.**



## WARNING

Failure to read and follow these instructions could result in separation of the towed vehicle from the tow bar, causing property damage, loss of towed vehicle, personal injury or death.

# BX1999

## 2011-2012 Mitsubishi Eclipse Spyder

### Installation Instructions

<b>Tools Required</b>	
Flat Screwdriver	8MM Socket
Utility Knife	10MM Socket
Phillips Screwdriver	14MM Socket
Torque Wrench	9/16" Socket
Drill	1-1/4" Hole Saw
Loctite® RED	13/32" Drill Bit
Diagonal Cutters	

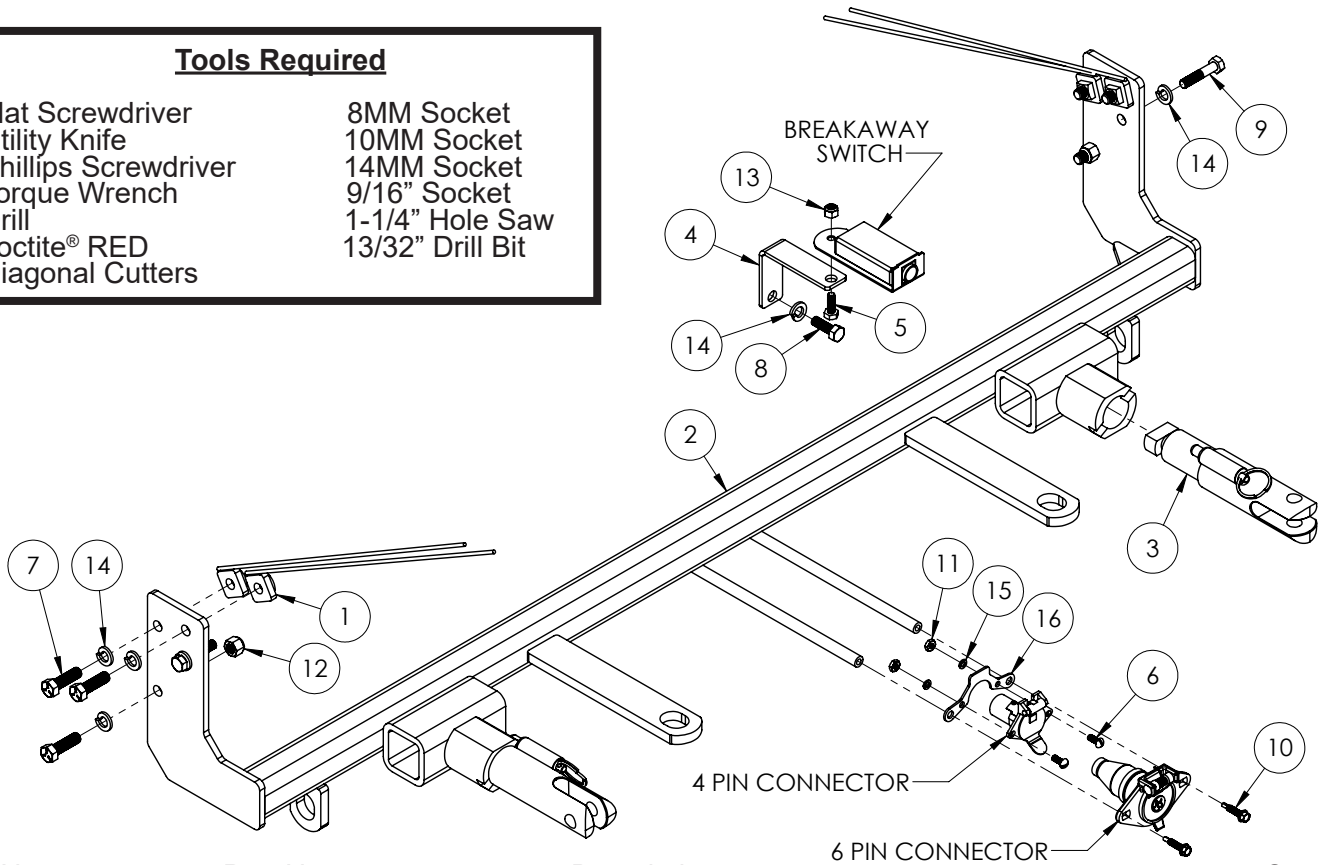

Item No.	Part No.	Description	Qty.
1.....	61-5208.....	3/8" Nut Plate w/ 14" Wire .....	4
2.....	61-6973.....	BX1999 Baseplate.....	1
3.....	62-3468.....	Attachment Tab Assembly with Hole .....	2
4.....	102-0050.....	1/4"-20 x 3/4" Hex Head Bolt, Grade 5, ZP .....	1
5.....	201-0050.....	1/4"-20 x 3/4" Hex Head Bolt, Grade 5, ZP .....	1
6.....	201-0192.....	#10-32 1/2" Round Slotted Head Screw.....	2
7.....	201-0368.....	3/8"-16 x 1-1/4" Hex Head Bolt, Grade 5, ZP .....	6
8.....	201-0378.....	8MM-1.25 x 25 MM Hex Head Bolt, Grade 8.8, ZP.....	1
9.....	201-0418.....	8MM-1.25 x 35 MM Hex Head Bolt, Grade 8.8, ZP.....	2
10.....	201-0979.....	#12-14 x 1" Self Drilling Screw, ZP.....	2
11.....	202-0047.....	#10-32 Hex Nut .....	2
12.....	202-0090.....	3/8"-16 Hex Nylon Insert Lock Nut, ZP.....	2
13.....	202-0102.....	1/4"-20 Hex Nylon Nut, ZP .....	1
14.....	203-0010.....	3/8" Lock Washer, ZP .....	9
15.....	203-0054.....	#10 Lock Washer, ZP .....	2
16.....	299-0685.....	4-Way Bracket.....	1
17.....	226-0046(not shown).....	Class III Safety Cables .....	2
18.....	229-0359(not shown).....	3/8" Quicklink, ZP .....	2
19.....	290-0437(not shown).....	Black Cap Plug Receiver.....	2

**Important:**

Use only genuine factory replacement parts on your baseplate. Do **NOT** substitute homemade or non-typical parts. If a bolt is lost or in need of replacement, for your safety and the preservation of your baseplate, be sure to use a replacement bolt of the same grade (In most cases it will be Grade 5, please reference the parts list above). Replacement parts may be ordered through your nearest Blue Ox® Dealer or Distributor. Failing to follow and/or altering these installation instructions in either installation or required equipment will void the manufacturer's warranty. Towing behind a non-motorized vehicle will void the warranty.

BX1999  
2011-2012 Mitsubishi Eclipse Spyder  
Installation Instructions

**Removable Tabs:** Motorhome mount tow bars are recommended for use with this baseplate. Due to the design of the removable tabs, the RangeFinderII and Ambassador tow bars can not be used. Adapters, except the BX8833, BX88262 and BX88151, can not be used with this baseplate.

**Instruction Notes:** The fascia, plastic fascia guard and bumper are removed and reinstalled for the baseplate installation. Temperature sensor is disconnected during installation and reconnected when baseplate installation is complete. Drilling is required. Trimming is required.

The dimensional variations between otherwise identical vehicles can be considerable. While the baseplate was designed for easy installation, it may be necessary to tailor the baseplate slightly to compensate for auto manufacturer's tolerances. These minor adjustments may include filing a hole slightly, bending electrical rods or bending end plates.

The BX8848 4-Diode Wiring Kit is recommended for this vehicle.

**Do not use the towed vehicle for storing luggage, equipment, etc. This may cause you to exceed the towing capacity of the tow bar, baseplate, and its accessories.**

**Handling of some cosmetic parts when installing this product may require the use of protective covers, rags, specialty tools, etc. to prevent damage.**

**Installation Instructions:**

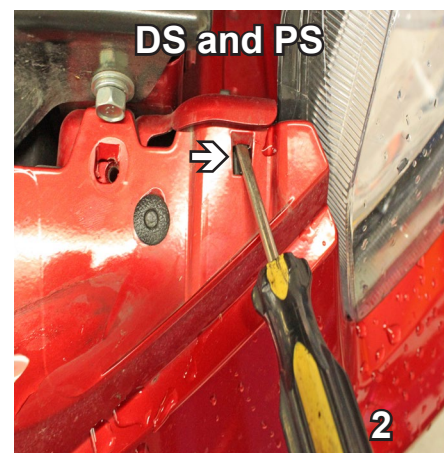
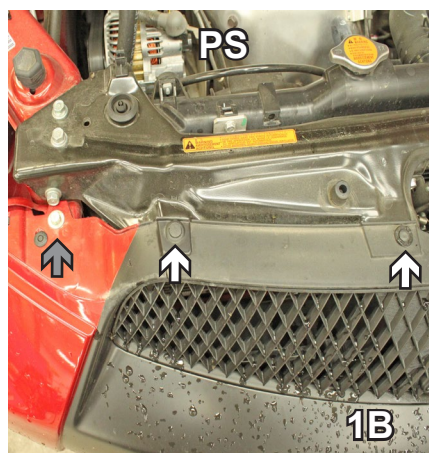
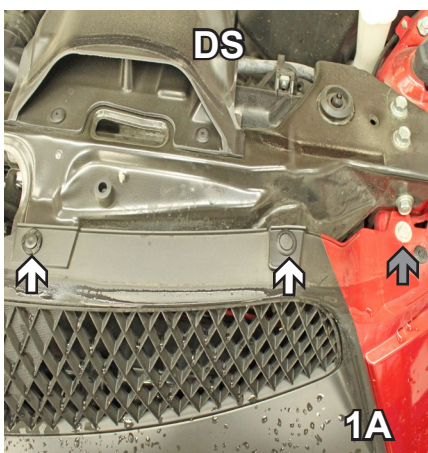

1. With flat screwdriver, remove four push pins from the top of the fascia (white arrows) and with 10MM socket, remove two 10MM bolts (gray arrows) (1A and 1B). Set push pins and bolts aside to be reinstalled later.
2. With flat screwdriver, release the pin holding on the plastic radiator cover by inserting it into the slotted area shown in the above picture. Do this to both sides of the vehicle.

BX1999  
2011-2012 Mitsubishi Eclipse Spyder  
Installation Instructions

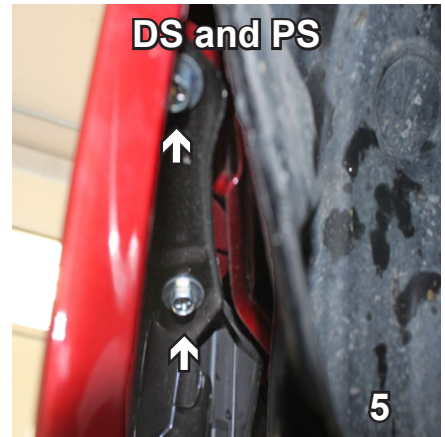
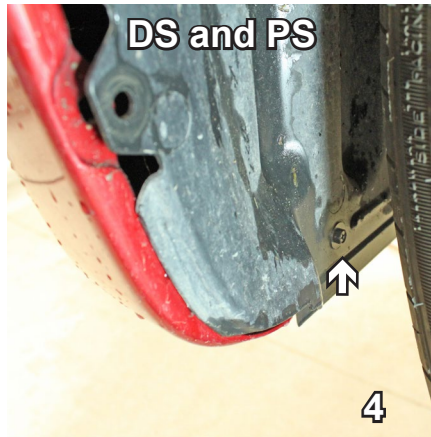

3. In front of tire, remove three push pins. Do this to both sides of the vehicle. Set push pins aside to be reinstalled later.
4. In front of tire, with 8MM socket, remove one bolt. Do this to both sides of the vehicle. Set bolts aside to be reinstalled later.
5. Pull wheel well cover back and with a 10MM socket, remove two bolts from inside the wheel well. Do this to both sides of the vehicle. Set bolts aside to be reinstalled later.

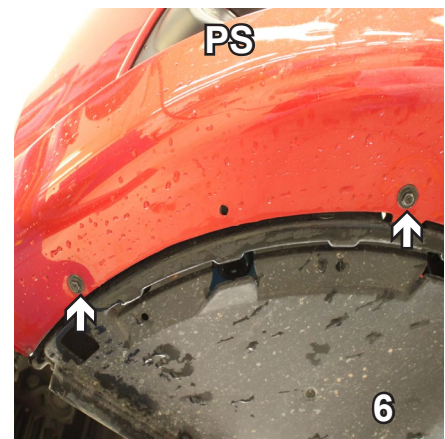
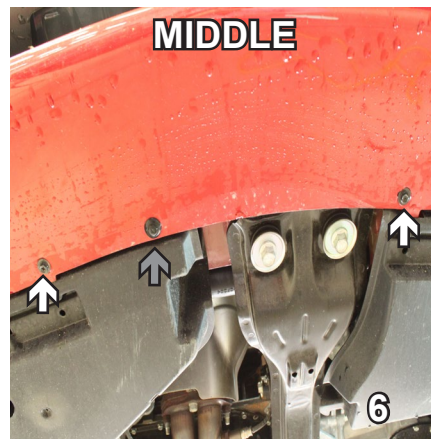
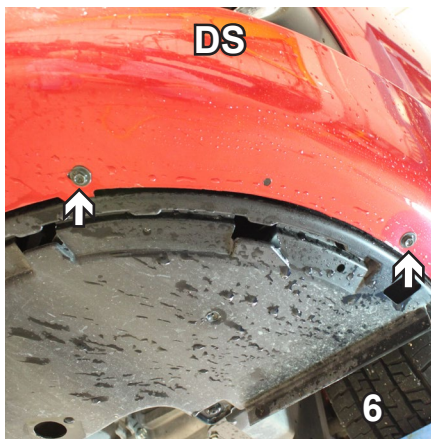

6. Underneath the fascia, with 8MM socket or Phillips screwdriver, remove six bolts (white arrows) and one push pin (gray arrow). Set bolts and push pin aside to be reinstalled later.

7. Underneath the fascia, remove two additional push pins. Set push pins aside to be reinstalled later. Carefully remove fascia and set aside. The fascia will be reinstalled after the baseplate installation is complete.



BX1999  
2011-2012 Mitsubishi Eclipse Spyder  
Installation Instructions

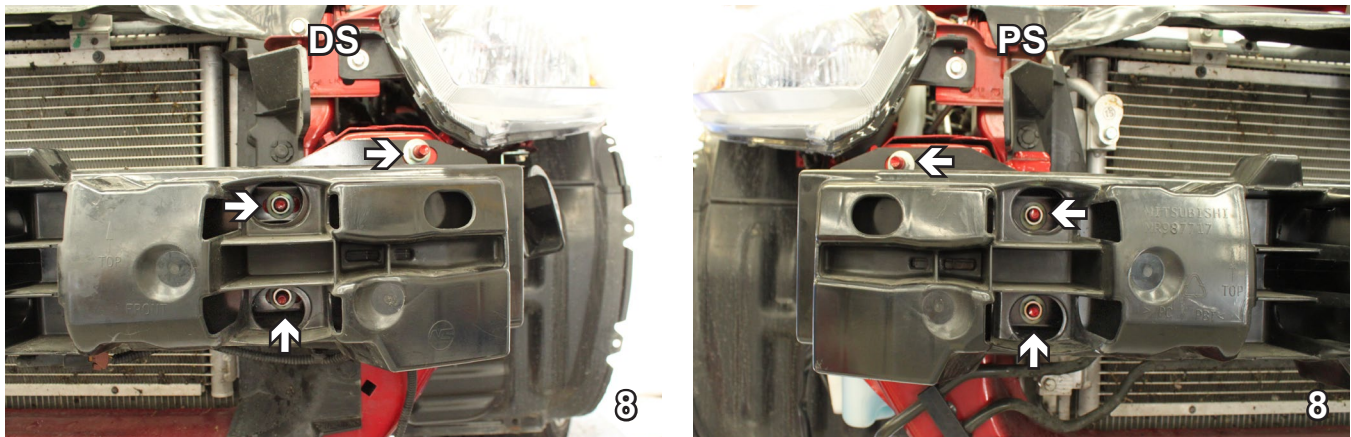

8. With a 14MM socket, remove three bolts from the bumper. Do this to both sides of the vehicle.

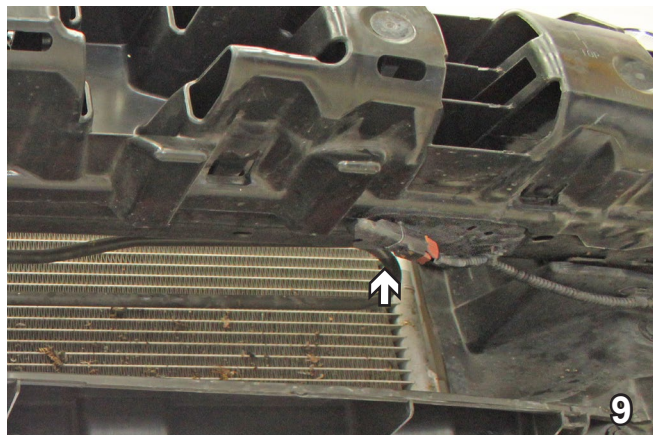

9. Disconnect the temperature sensor from the driver's side underneath the bumper. Move temperature sensor aside and remove bumper. Set bumper aside to be reinstalled later.

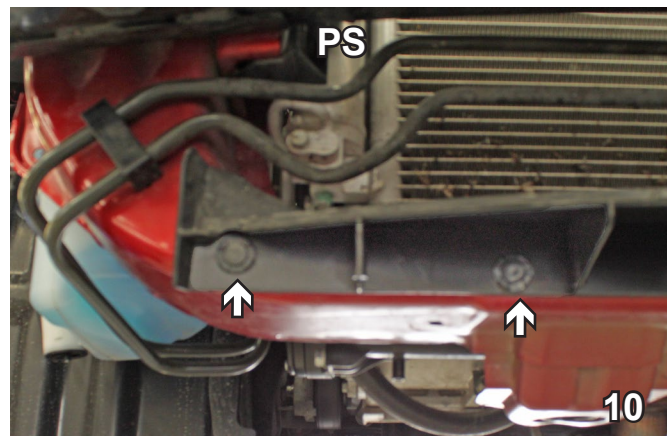
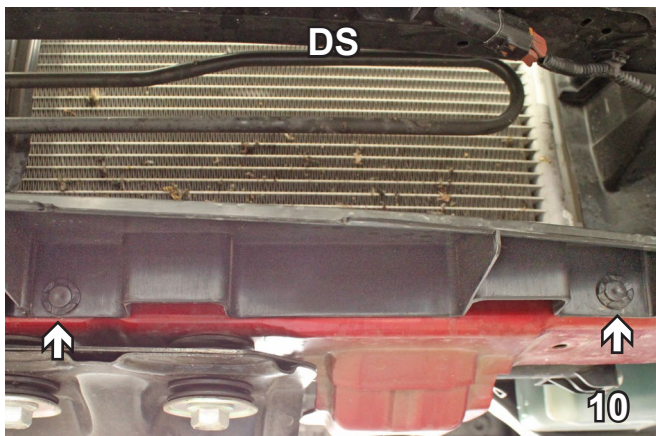

10. To remove plastic fascia guard, with a flat screwdriver, remove four push pins. Set push pins and plastic fascia guard aside to be reinstalled later.

BX1999  
2011-2012 Mitsubishi Eclipse Spyder  
Installation Instructions

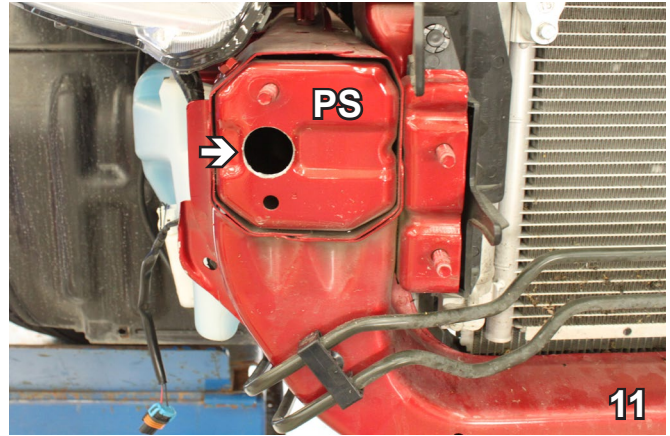
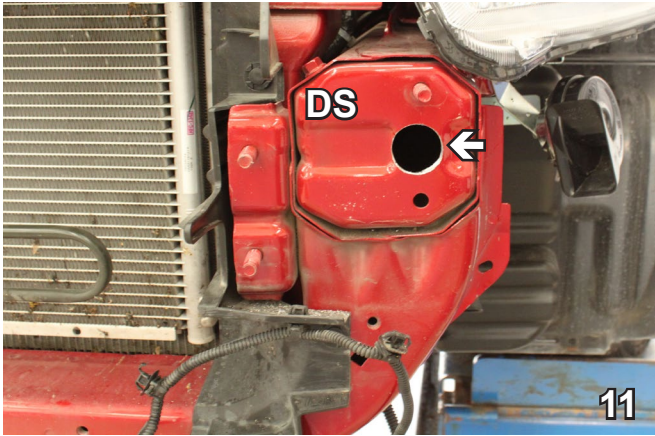

11. With 1-1/4" hole saw, drill through the bumper horn as shown above to accommodate installation of welded nut plates. Do this on both sides of the vehicle.

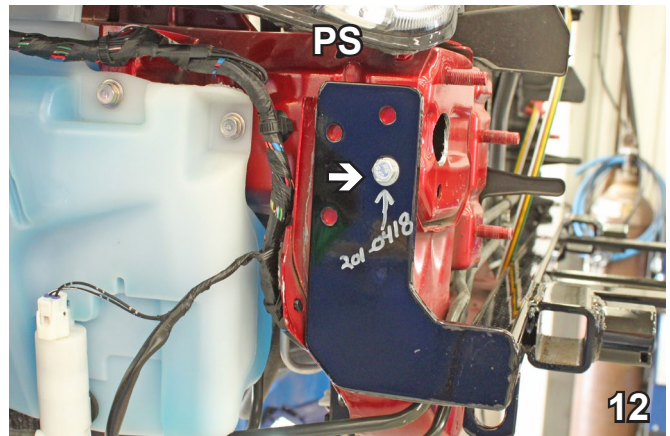
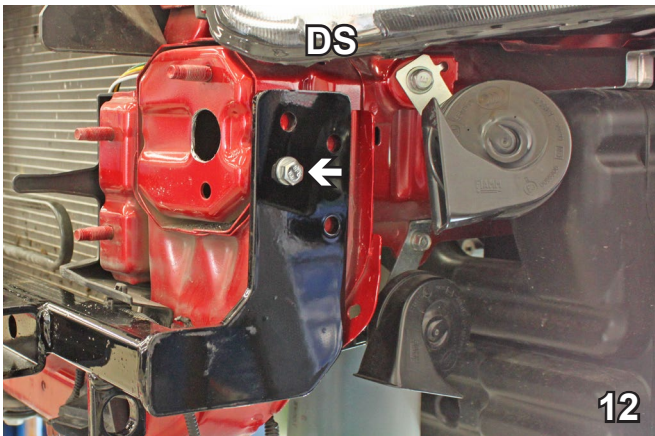

12. Slide baseplate up to the frame of the vehicle, aligning with the existing holes as shown. Ensure baseplate always remains level. In existing holes, install 8MM-1.25 x 35MM hex bolt with 3/8" lock washer. Do this on both sides of the vehicle. Use Loctite Red on all bolts.

**BE SURE TO USE LOCTITE® RED ON ALL BOLTS BEFORE TIGHTENING. TIGHTEN ALL BOLTS ACCORDING TO THE TORQUE CHART ON THE FRONT PAGE OF THESE INSTRUCTIONS OR ON PAGE 3 OF THE BASEPLATE TOWING GENERAL INSTRUCTIONS.**

**When using power drills be aware of the dangers of torque and drill bit length.**

BX1999  
 2011-2012 Mitsubishi Eclipse Spyder  
 Installation Instructions

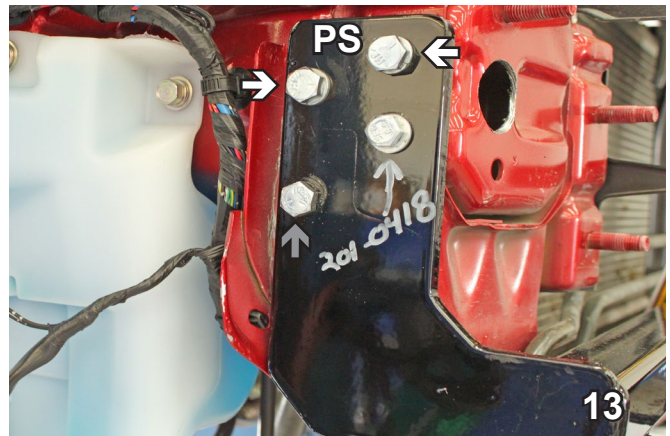
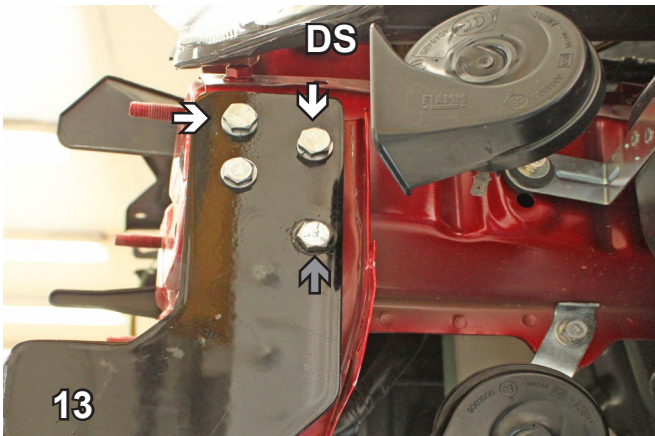

13. With 13/32" drill bit, using the baseplate as a template, drill remaining three holes on both sides of the vehicle. Install 3/8-16 x 1-1/4 hex bolts with 3/8" lock washers and welded nut plates into the top two holes of the baseplate (white arrows). Insert 3/8-16 x 1-1/4 hex bolts with 3/8-16 hex nylon insert lock nuts into the bottom holes (gray arrows). Do this on both sides of the vehicle. Always ensure baseplate remains level. Use Loctite Red on all bolts.



14. Hold fascia up as close as possible to its original position. Mark area on fascia where trimming will be required to have attachment tabs, quicklinks and breakaway bracket (if applicable) to come through. If fascia is metal, use diagonal cutters to trim the fascia openings you have marked. If fascia is plastic, a utility knife can be used for trimming.

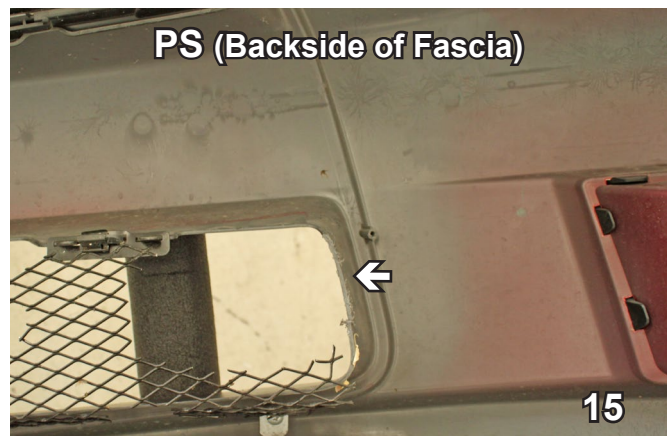

15. With Phillips screwdriver, remove two screws on the upper corners of the fascia. Trim additional area as shown in the pictures above to allow baseplate to come through the fascia. With a utility knife, trim back the outer edges of the fascia opening (white arrows). Do this on both sides of the fascia opening.

BX1999  
2011-2012 Mitsubishi Eclipse Spyder  
Installation Instructions

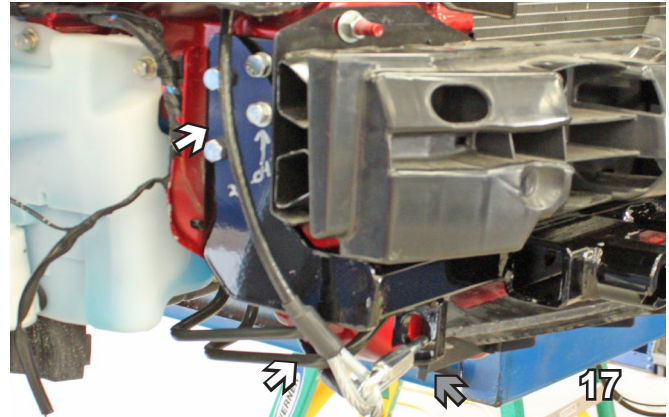
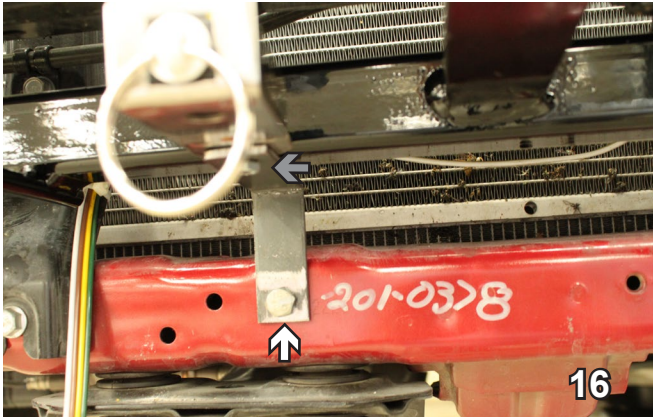

16. OPTIONAL: Install the breakaway bracket and breakaway on the driver's side of the vehicle between the quicklinks and electrical rods. Using existing hole on the frame underneath the baseplate, insert 8MM-1.25 x 25 hex bolt and 3/8" lock washer to secure the bracket (white arrow). Attach breakaway to the bracket with 1/4-20 x 3/4 hex bolt with 1/4-20 nyl nut (gray arrow). Reinstall bumper and reconnect temperature sensor.
17. Attach the permanent baseplate safety cables to the provided convenience link on the baseplate (gray arrow). The photo above shows the recommended installation of the cables to frame of vehicle (white arrows). Additional options may interfere with suggested mounting; in this case, secure the cables to a solid piece of the frame as described in the instructions included with the permanent baseplate safety cables. Be sure the safety cables do not rub against any hoses or moving parts. Do this on both sides of the vehicle.
18. Reinstall plastic fascia guard.
19. Reinstall fascia.

Install the tow bar and safety cables according to the instructions provided in their packages. When demonstrating this to the customer, be sure to include all the contents and packages.

Do not substitute other devices if the tow bar pins and clips are misplaced.

**DEALER or INSTALLER:**  
Be certain the user receives the instruction sheets for their products.

Be sure that **ALL** electrical connections are plugged in properly and functioning **BEFORE** installing the fascia.



BX1999  
2011-2012 Mitsubishi Eclipse Spyder  
Installation Instructions



Shown with removable tabs installed



Shown without removable tabs installed

## CUSTOMER SERVICE COMMITMENT

Blue Ox® is committed to providing you with exceptional customer care throughout your lifetime with our products. Our team is here to assist you with any questions you may have regarding the performance of your product. Simply call (402) 385-3051 and you can speak with our technical service team.

Additionally, please visit our website to see which rallies our Destination America team will be attending. For a nominal fee, our service technician will service your towing system to ensure it's in proper working condition. Also, as a commitment to our customers, should you visit our factory, you can stay at our full service Blue Ox® campground at no charge along with enjoying a factory tour.

Again, thank you for being our customer and for the confidence you have shown in the performance of our products. It is because of customers like you we enjoy the success we have today.

**If the baseplate is in an accident, it must be replaced. DO NOT use it again! An accident can cause unseen damage and using it again could result in more damage or serious injury. DO NOT use the baseplate if it is damaged or missing parts.**

© 2016 Blue Ox  
One Mill Road, Industrial Park  
Pender, Nebraska 68047  
Phone: (402) 385-3051  
Fax: (402) 385-3360  
[www.blueox.com](http://www.blueox.com)

# General Information

1. Ensure that your product(s) are registered online at [www.blueox.com](http://www.blueox.com). It is crucial to register your product(s) so that you may be alerted of product offerings, updates, upgrades, maintenance and safety bulletins, and/or recalls.
2. **It is the owner's responsibility to inspect all towing equipment for cracked welds, missing or worn parts and loose bolts before each towing trip.** Be sure to use Loctite® Red on all bolts and tighten to the recommended specifications.
3. **It is the owner's responsibility to hook up all towing equipment per manufacturer's instructions/recommendations.**
4. Remove the attachment tabs when not in use (if applicable).

## Notice To Baseplate Installer

### 1. It is YOUR responsibility to watch for:

- Oil cooler and air conditioner lines
- Electrical wires and hoses
- Missing parts or attaching points on the frame

\*\* If the baseplate is improperly installed and is against a wire or hose, it could cause fluid leaks or electrical shorts some time after the actual baseplate installation.

## Permanent Baseplate Safety Cable Installation

Permanent baseplate safety cables are strongly recommended when towing a vehicle with a tow bar. The principle function of the permanent baseplate safety cables is to prevent the towed vehicle from breaking loose in the event the connection between the frame of the towed vehicle and the baseplate fails or becomes disconnected. The cables must be connected from the baseplate to the frame rail or cross member of the vehicle's frame. The illustrations below show the possible arrangements recommended by Blue Ox®. Each permanent baseplate safety cable must have an adequate weight rating for the towing system. The weight rating of the two (2) cables together will not qualify.

***Do not mount the permanent baseplate safety cables against wires, hoses or brake lines.***

These permanent baseplate safety cables should remain installed as long as the baseplate is installed on the vehicle. Permanent baseplate safety cables are to be used in conjunction with, and NOT a replacement for legally required safety cables attaching the towed vehicle to the towing vehicle.

### OPTION #1

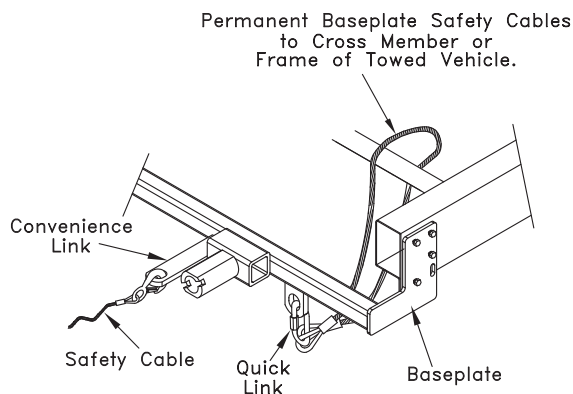

### OPTION #2

