



## BX1825 Installation Instructions 2000-04 Nissan XTerra (V-6) 2001-04 Nissan Frontier (2WD/ 4WD)

Serial No.

The baseplate mounts to the top of the frame and frame brackets. The attachment tabs will extend through the grill opening four inches. A plastic molded guard located directly behind the bumper is permanently removed (2000 model only). Six 13/32" holes need to be drilled for installation.

1. Remove the bolt that holds the rod support to the outside ends of the bumper. Remove the push pins from bottom of bumper. Locate the bolt above the rods that holds the outside edges of bumper to the frame (in front of the tires and above the rubber cushion). Facing the bumper and looking through the grill are bolts that fasten the bumper to the outside brackets and to each frame. Reach inside the grill opening and remove these bolts. Remove the bolts holding the plastic guard to the bumper. Be careful the bumper does not fall.

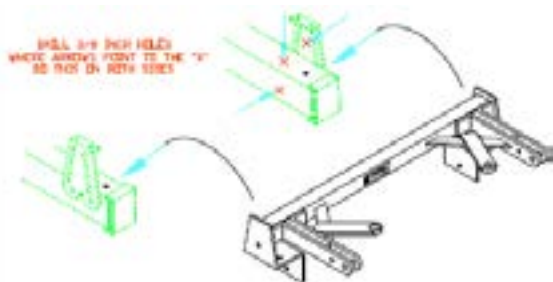

Diagram 1

2. Locate the two existing holes on top of each frame, place the baseplate (Item 1) on the frame. Line up the top front hole to the existing holes. **Note:** Some models may not have the hole in the top of frame. Clamp baseplate to frame with vise grips, slide bumper into its original position and adjust baseplate forward as needed. Remove bumper. Using the baseplate as a template, drill all holes, both sides. See Diagram 1.
3. Inside the frame is a piece of metal obstructing the top back holes. Use a screw driver to push the metal back so a bolt can be inserted. On the front of each frame is a piece of metal. Pry open a large enough gap so the wire nuts (Item 2) can be inserted. See Diagram 2. **Note:** Some models may have end cap welded to frame and will require a 1" holes to be drilled into end of frame with the 1" holes saw.

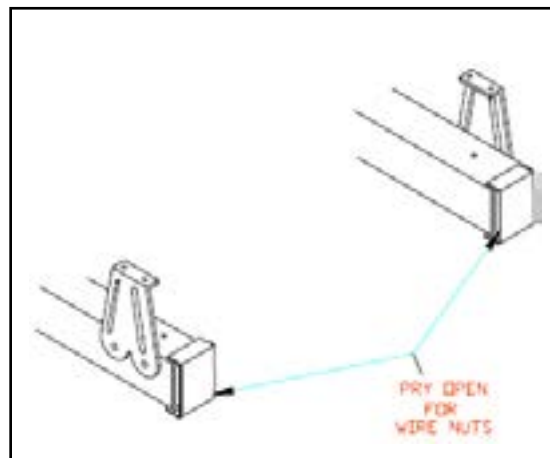
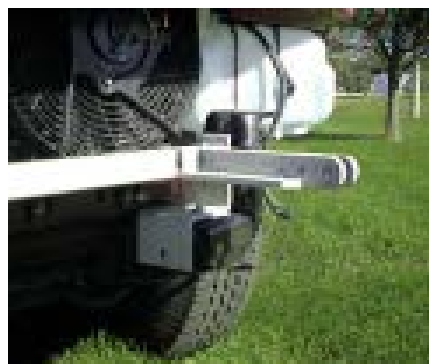

Diagram 2

4. Bolt the baseplate to the frame. Be sure and use loctite on all bolts before tightening. Tighten all bolts according to torque chart in the General Instruction sheet.
5. Replace the bumper. **Note: The plastic piece removed in Step 3 is not replaced (2000 Models only). Be sure to give the piece to the owner.**
6. Install the tow bar and safety cables according to the instructions included in their packages.
7. Do not substitute other devices if the tow bar pins or clips are lost.
8. **DEALER OR INSTALLER: BE CERTAIN THE USER RECEIVES THE INSTRUCTION SHEET.**





## Tools Required

- |                       |               |               |             |
|-----------------------|---------------|---------------|-------------|
| 10MM Wrench           | 10MM Socket   | 12MM Wrench   | 12MM Socket |
| Phillips Screw Driver | Small Pry Bar | 3/8 Drill Bit | Loctite Red |
| 1" Hole Saw           |               |               |             |

## Parts List

Ref. No.	Qty.	Part No.	Description
1	1	61-5449	Weldment Baseplate, BX1825
2	6	61-4902	3/8 Wire Nut
3	8	201-0368	3/8-16 x 1 1/4 Hex Bolt, Grade 5
4	2	202-0003	3/8 Hex Nut
5	8	203-0010	3/8 Lock Washer
6	2	201-0979	#12-14 X 1" Self Drilling Screw, ZP
7	2	101-5822	Adapter, 4 Way Connector
8	2	201-0192	#10-32 x 1/2 Screw
9	2	202-0047	#10-32 Hex Nut
10	2	203-0054	#10 Lock Washer

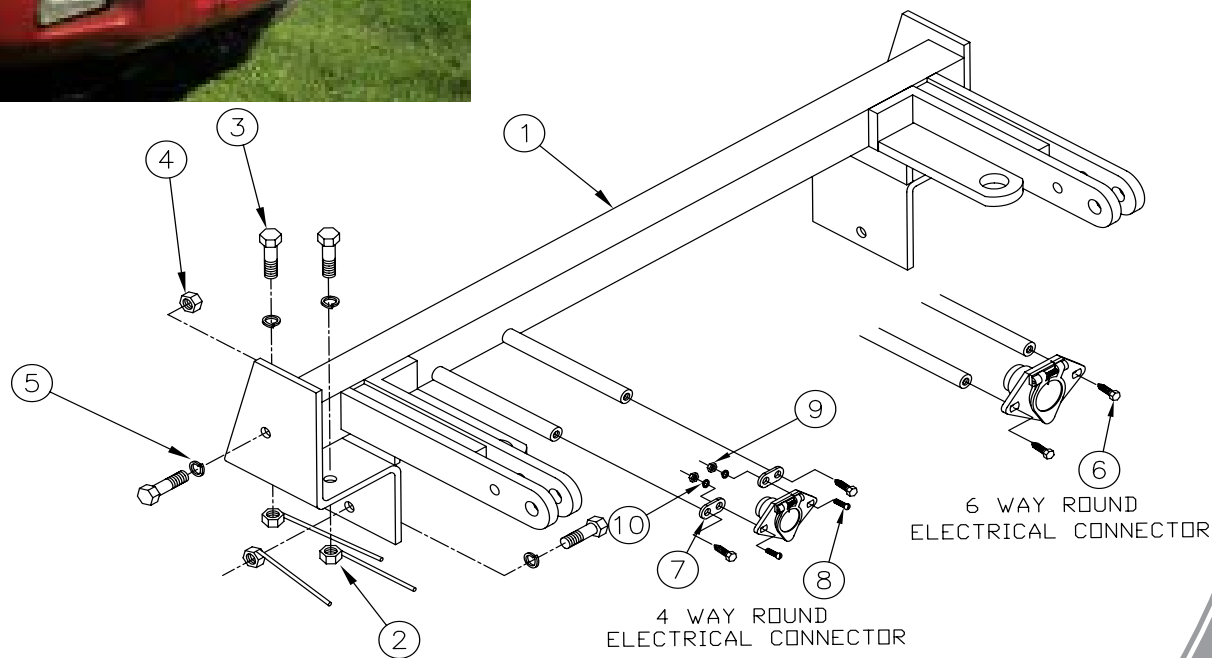

# General Information

1. Ensure that your product(s) are registered online at [www.blueox.com](http://www.blueox.com). It is crucial to register your product(s) so that you may be alerted of product offerings, updates, upgrades, maintenance and safety bulletins, and/or recalls.
2. **It is the owner's responsibility to inspect all towing equipment for cracked welds, missing or worn parts and loose bolts before each towing trip.** Be sure to use Loctite® Red on all bolts and tighten to the recommended specifications.
3. **It is the owner's responsibility to hook up all towing equipment per manufacturer's instructions/recommendations.**
4. Remove the attachment tabs when not in use (if applicable).

## Notice To Baseplate Installer

### 1. It is YOUR responsibility to watch for:

- Oil cooler and air conditioner lines
- Electrical wires and hoses
- Missing parts or attaching points on the frame

\*\* If the baseplate is improperly installed and is against a wire or hose, it could cause fluid leaks or electrical shorts some time after the actual baseplate installation.

## Permanent Baseplate Safety Cable Installation

Permanent baseplate safety cables are strongly recommended when towing a vehicle with a tow bar. The principle function of the permanent baseplate safety cables is to prevent the towed vehicle from breaking loose in the event the connection between the frame of the towed vehicle and the baseplate fails or becomes disconnected. The cables must be connected from the baseplate to the frame rail or cross member of the vehicle's frame. The illustrations below show the possible arrangements recommended by Blue Ox®. Each permanent baseplate safety cable must have an adequate weight rating for the towing system. The weight rating of the two (2) cables together will not qualify.

***Do not mount the permanent baseplate safety cables against wires, hoses or brake lines.***

These permanent baseplate safety cables should remain installed as long as the baseplate is installed on the vehicle. Permanent baseplate safety cables are to be used in conjunction with, and NOT a replacement for legally required safety cables attaching the towed vehicle to the towing vehicle.

### OPTION #1

Permanent Baseplate Safety Cables to Cross Member or Frame of Towed Vehicle.

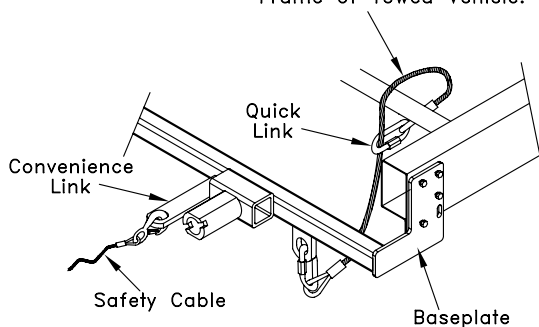

### OPTION #2

Permanent Baseplate Safety Cables to Cross Member or Frame of Towed Vehicle.

