

**Serial Number**

**Please read BOTH these Installation Instructions and the General Instructions before attempting to install or operate this equipment.**

- Blue Ox® towing products and accessories are intended to be installed by Blue Ox® Dealers who are familiar with our products and have the equipment necessary and knowledge to do "fit work". When necessary Blue Ox® Dealers can be found at [www.blueox.us](http://www.blueox.us) or by contacting our Customer Care Department at (402) 385-3051 or toll free (888) 425-5382.
- Many Blue Ox® Baseplates are designed to use existing holes and hardware to mount the baseplate to the towed vehicle. Even though bolts are there, do not assume they are adequate for baseplate mounting. Always use hardware supplied in the hardware kit and existing hardware specified in the Baseplate Installation Instructions.

Attachment Tab Height: 13"  
Attachment Tab Width: 23.5"

**Bolt Torque Specifications**  
Torque in Foot-Pounds for Metric Bolts

Bolt Size	Grade 8.8	Grade 10.9
6MM	6	8
8MM	16	22
10MM	31	40
12MM	54	70
14MM	89	117

Confirm the towability and pre-towing procedures for your vehicle with the owner's manual or contact the vehicle's manufacturer for specific towing procedures.

**Bolt Torque Specifications**  
Torque in Foot-Pounds for Inch Bolts

Bolt Size	Grade 5	Grade 8
1/4"	10	14
5/16"	19	29
3/8"	33	47
7/16"	54	78
1/2"	78	119
5/8"	154	230



**! WARNING**

Failure to read and follow these instructions could result in separation of the towed vehicle from the tow bar, causing property damage, loss of towed vehicle, personal injury or death.

# BX1666 2006-07

## Chevrolet Malibu Installation Instructions

### Parts List

Ref. No.	Qty.	Part #	Description
1	1	61-6194	Weldment, Baseplate, BX1666
2	3	61-5208	3/8" Nutplate, with wire
3	7	201-0368	3/8-16 x 1 1/2 Bolt, Grd. 5, ZP
4	7	203-0010	3/8" Lock Washer, ZP
5	4	202-0003	3/8-16 hex Nut, ZP
6	1	201-0655	6MM-1 x 30MM Hex Bolt, Grd. 8.8, ZP
7	1	203-0008	1/4" Lock Washer, ZP
8	1	203-0001	1/4" Flat washer, ZP
9	2	201-0979	#12-14 x 1" Self Drilling Screw, ZP
10	2	201-0192	#10-32 x 1/2 Slot Rd. Hd. Screw
11	2	203-0054	#10 Lock Washer, ZP
12	2	202-0047	#10-32 Hex Nut, ZP
13	2	101-5822	Adapter, 4 way Connector
14	2	62-3469	Attachment, Assembly, SF/LB (R)
	2	226-0046	Baseplate Safety Cable, 36" CL III (Not Shown)
	4	229-0359	Quicklink, 3/8, ZP (Not Shown)
	2	290-0437	Cap Plug (Not Shown)

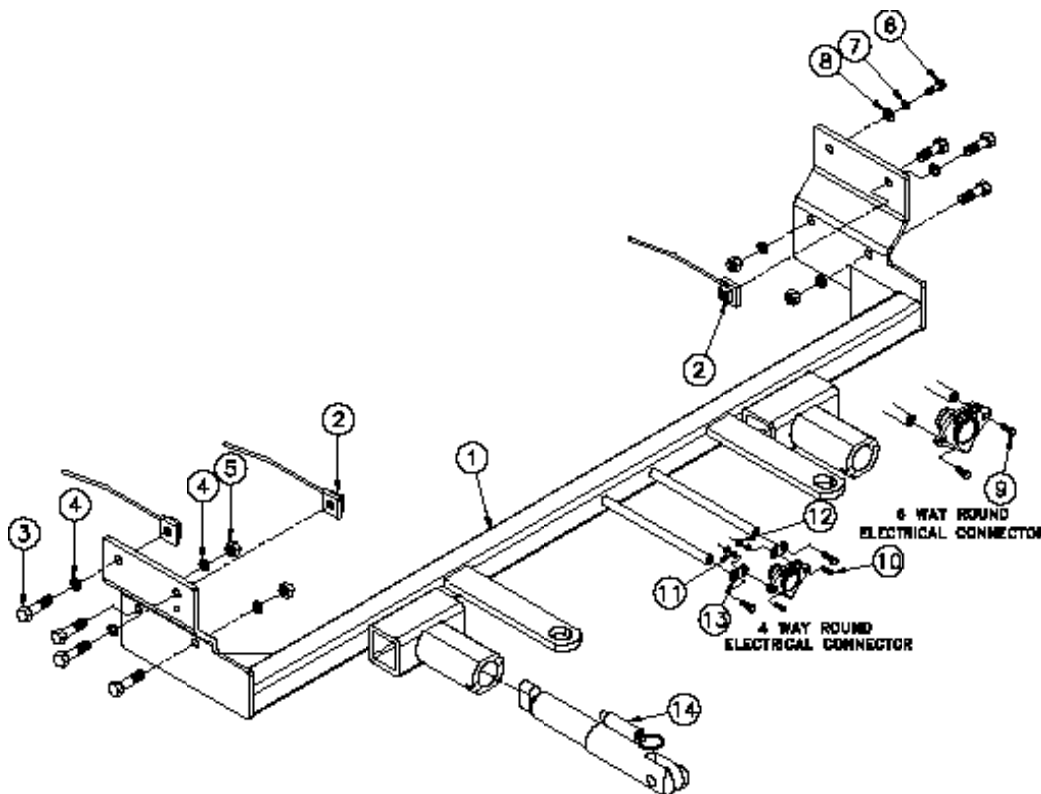

### Tools Required

Loctite® RED  
 7MM Socket  
 10MM Socket  
 9/16" Socket  
 13/32" Drill Bit  
 1/4" Drill Bit  
 Pliers  
 Phillips Screwdriver  
 Large Vise Grips  
 Utility Knife

### Important:

Use only genuine factory replacement parts on your baseplate. Do NOT substitute homemade or non-typical parts. If a bolt is lost or in need of replacement, for your safety and the preservation of your baseplate, be sure to use a replacement bolt of the same grade (In most cases it will be Grade 5, please reference the parts list above). Replacement parts may be ordered through your nearest Blue Ox® Dealer or Distributor, or call our Customer Care Team at (402)385-3051. Failing to follow and/or altering these installation instructions in either installation or required equipment will void the manufacturer's warranty.

# BX1666 2006-07

## Chevrolet Malibu Installation Instructions

### Attachment Tabs:

Due to the design of the removable tabs, the RangeFinder II, Adventurer, and Ambassador tow bars can not be used. Adapters, except the BX8833 and BX88151, can not be used with this baseplate.

### Instructions:

The front fascia, headlights, horn bracket, and air baffle are removed for the baseplate installation. Drilling is required. Trimming of the air dam and the grille is required.

The dimensional variations between otherwise identical vehicles can be considerable. While the baseplate was designed for easy installation, it may be necessary to tailor the baseplate slightly to compensate for auto manufacturer's tolerances. These minor adjustments may include filing a hole slightly, bending electrical rods or bending end plates.

The BX8869 Bulb and Socket Wiring Kit is recommended for this vehicle.



### Installation Instructions:

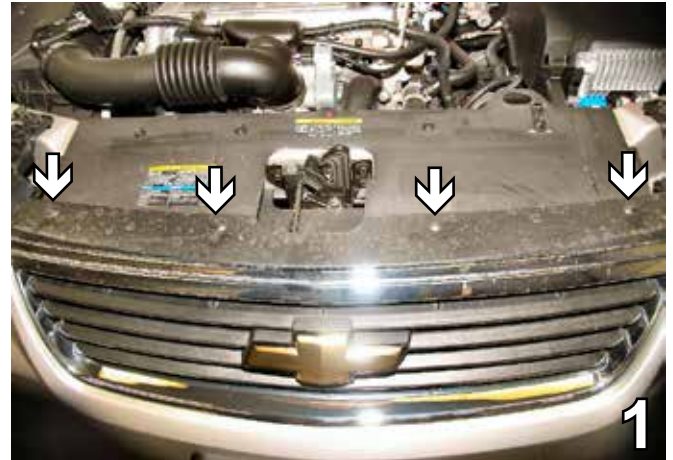

1. Using the Phillips screwdriver, remove four Phillips pushpins from the black plastic cover on the top side of the fascia. Set pushpins and plastic cover aside to reinstall later.



2. Using the 10MM socket, remove two metric bolts from the headlight assembly. Pull the headlight assembly forward and disconnect electrical connections. Do this to both sides of the vehicle. Set bolts and headlight assemblies aside to reinstall later.

BX1666  
2006-07  
Chevrolet Malibu  
Installation Instructions



3. Just forward of the front tire, on the edge of the wheel well cover, remove three Christmas tree pushpins, as indicated by the white arrows in the photo above, and one Phillips pushpin, as indicated by the grey arrow in the photo above. Do this to both sides of the vehicle. Set pushpins aside to reinstall later.

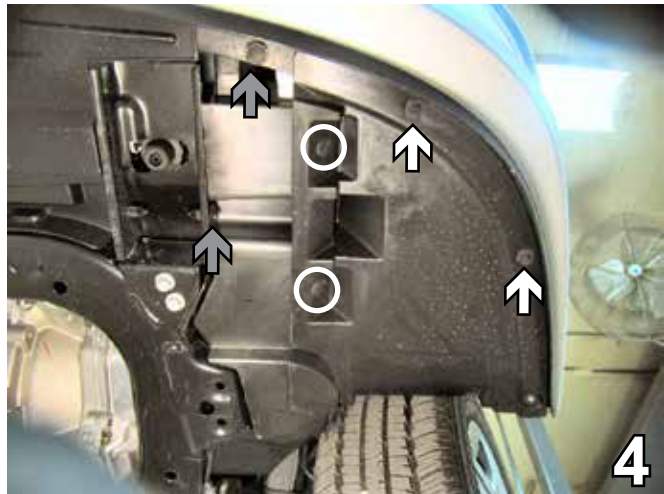

4. Using the 7MM socket, remove two metric bolts from underneath corner of the front fascia, forward of the front tire, as indicated by the white arrows in the photo above. Remove two Christmas tree pushpins, as indicated by the circles in the photo above. Remove two pushpins, as indicated by the grey arrows in the photo above. Do this to both sides of the vehicle. Set bolts and pushpins aside to reinstall later.



5. Using the 7MM socket, remove three metric bolts underneath the fascia. Set bolts aside to reinstall later.



6. Remove two pushpins from the fascia tabs. Do this to both sides of the vehicle. Set pushpins aside to reinstall later.

BX1666  
2006-07  
Chevrolet Malibu  
Installation Instructions



7. Using the 10MM socket, remove one metric bolt from the corner of the fascia, just forward of the front tires, inside the headlight assembly. Do this to both sides of the vehicle. Set bolts aside to reinstall later.



8. Using the 10MM socket, remove one metric bolt from the driver's side horn bracket. Disconnect the horn. Set bolt, bracket, and horn aside to reinstall later.

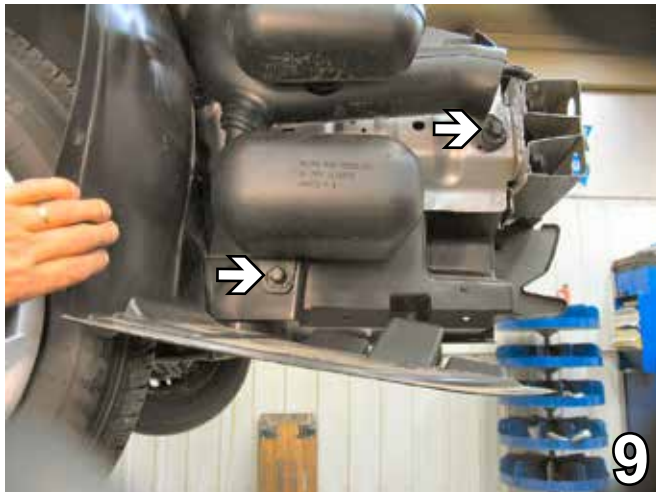

9. Remove two pushpins from the passenger's side air baffle. Set bolts and air baffle to reinstall later.

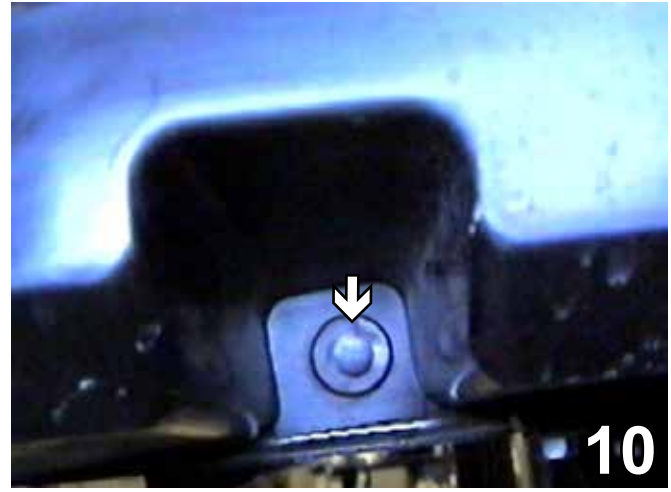

10. Remove one push pin from the lower plastic on the bottom rib of the frame rail. Do this to both sides of the vehicle. Set pushpins aside to reinstall later.

BX1666  
2006-07  
Chevrolet Malibu  
Installation Instructions



11. Remove one pushpin from the passenger's side of the air dam. Pull air dam down to clear area for baseplate installation. Set bolt aside to reinstall later.



12. Remove two pushpins near the bottom of the wheel well cover on the passenger's side, and one pushpin on the driver's side. Set pushpins aside to reinstall later.



13. Align the baseplate on the driver's side so the upper back hole aligns with the existing horn bracket hole and clamp in place with vise grips.



14. Using the baseplate as a template, drill the remaining three holes into the frame rail on the driver's side with the 13/32" drill bit. Insert two 3/8-16 x 1 1/2" hex bolts, 3/8-16 hex nuts and 3/8 lock washers into the bottom two holes. Guide a 3/8" nut plate up through the opening in the bottom of the frame rail and align it with the upper front bolt hole. Install the 3/8-16 x 1 1/2" hex bolt and the 3/8" lock washer to the 3/8-16 nut plate.

**BE SURE TO USE LOCTITE® RED ON ALL BOLTS BEFORE TIGHTENING. TIGHTEN ALL BOLTS ACCORDING TO THE TORQUE CHART ON THE FRONT PAGE OF THESE INSTRUCTIONS OR ON PAGE 3 OF THE BASEPLATE TOWING GENERAL INSTRUCTIONS.**

# BX1666 2006-07

## Chevrolet Malibu Installation Instructions

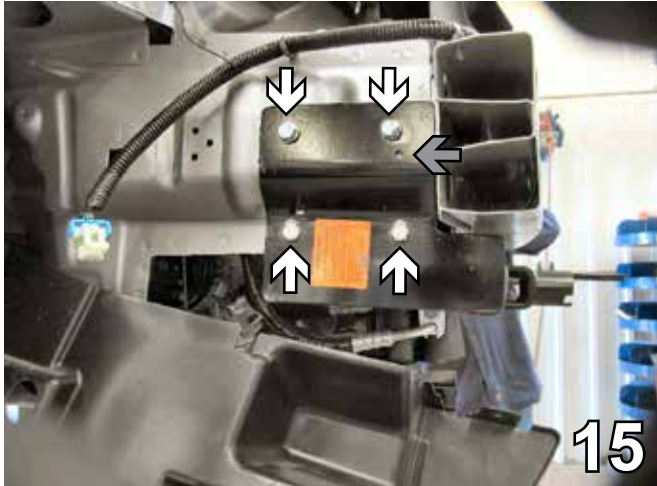

15. Using the baseplate as a template, drill the four corner holes into the frame rail on the passenger's side, as indicated by the white arrows in the photo above, with the 13/32" drill bit. Insert two 3/8-16 x 1 1/2" hex bolts, 3/8-16 hex nuts and 3/8 lock washers into the bottom two holes. Guide the 3/8" nut plates up through the opening in the bottom of the frame rail and align them with the upper bolt holes. Install the 3/8-16 x 1 1/2" hex bolts and the 3/8" lock washers to the 3/8-16 nut plates. Drill the remaining hole in the baseplate, as indicated by the grey arrow in the photo above, with the 1/4" drill bit. This hole will be used to reinstall the horn bracket.



16. Mark the passenger's side of the air dam from the front portion of lip diagonally to the bend and down 3 inches around the contour of the air dam mold. Then mark straight down from the air dam tab three inches and horizontally back to the air dam contour and trim this area with the utility knife.



17. On the passenger's side upper rear of the air dam, use the utility knife to make a one inch horizontal cut level with the opening next to the air dam then trim vertically to remove this portion of the air dam.



18. On the passenger's side of the air dam, just behind the tab, mark three inches down and two inches horizontally. Then mark upwards, following the contour of the air dam, to the top of the air dam and trim away this area with the utility knife.

BX1666  
2006-07  
Chevrolet Malibu  
Installation Instructions



19. On the driver's side, just behind the tab of air dam, cut down three inches. Then, cut horizontally toward rear of air dam approximately two inches. Cut upwards to the top, following the contour of the air dam.



20. On the driver's side, approximately one inch from the top of the air dam, cut horizontally from the front of the air dam to the back.



21. Using the pliers, straighten the tab of the horn bracket. There is no longer a hole for inserting this tab.



22. Using the 10MM socket, secure the horn bracket using a 6 x 1 x 30MM hex bolt with 1/4" lock washer and 1/4" flat washer.

23. Hold the fascia up to its original position and using the utility knife, trim the grille style so that the attachment tab is able to come through the grille.

24. Reinstall the headlight assemblies, and reconnect electrical cables.

25. Reinstall fascia inserting all bolts and pushpins. Installation of the baseplate is now complete.





# BX1666 2006-07

## Chevrolet Malibu

### Installation Instructions

**Be sure that ALL electrical connections are plugged in properly and functioning BEFORE Installing the fascia.**

Install the tow bar and safety cables according to the instructions when demonstrating this to the customer. Be sure to include all the contents and packages.

Do **NOT** substitute other devices if the tow bar pins and clips are misplaced.



If the baseplate is in an accident, it must be replaced. **DO NOT** use it again! An accident can cause unseen damage and using it again could result in more damage or serious injury. **DO NOT** use the baseplate if it is damaged or missing parts.

### **DEALER OR INSTALLER:**

**Be certain the user receives the instruction sheets for their products.**

### **CUSTOMER SERVICE COMMITMENT**

Blue Ox is committed to providing you with exceptional customer care throughout your lifetime with our products. Our team is here to assist you with any questions you may have regarding the performance of your product. Simply call 1-800-228-9289 and you can speak with our customer care team.

Additionally, please visit our website to see which rallies our Destination America team will be attending. For a nominal fee, our service technician will service your towing system to ensure it's in proper working condition. Also as a commitment to our customers, should you visit our factory you can stay at our full service Blue Ox campground at no charge along with enjoying a factory tour.

Again thank you for being our customer and for the confidence you have shown in the performance of our products. It is because of customers like you we enjoy the success we have today.



© 2005, 09 Blue Ox  
One Mill Road, Industrial Park  
Pender, Nebraska 68047  
Phone: (402) 385-3051  
Toll Free: (888) 425-5382  
Fax: (402) 385-3360  
www.blueox.us  
10/30/09

# General Information

1. Ensure that your product(s) are registered online at [www.blueox.com](http://www.blueox.com). It is crucial to register your product(s) so that you may be alerted of product offerings, updates, upgrades, maintenance and safety bulletins, and/or recalls.
2. **It is the owner's responsibility to inspect all towing equipment for cracked welds, missing or worn parts and loose bolts before each towing trip.** Be sure to use Loctite® Red on all bolts and tighten to the recommended specifications.
3. **It is the owner's responsibility to hook up all towing equipment per manufacturer's instructions/recommendations.**
4. Remove the attachment tabs when not in use (if applicable).

## Notice To Baseplate Installer

### 1. It is YOUR responsibility to watch for:

- Oil cooler and air conditioner lines
- Electrical wires and hoses
- Missing parts or attaching points on the frame

\*\* If the baseplate is improperly installed and is against a wire or hose, it could cause fluid leaks or electrical shorts some time after the actual baseplate installation.

## Permanent Baseplate Safety Cable Installation

Permanent baseplate safety cables are strongly recommended when towing a vehicle with a tow bar. The principle function of the permanent baseplate safety cables is to prevent the towed vehicle from breaking loose in the event the connection between the frame of the towed vehicle and the baseplate fails or becomes disconnected. The cables must be connected from the baseplate to the frame rail or cross member of the vehicle's frame. The illustrations below show the possible arrangements recommended by Blue Ox®. Each permanent baseplate safety cable must have an adequate weight rating for the towing system. The weight rating of the two (2) cables together will not qualify.

***Do not mount the permanent baseplate safety cables against wires, hoses or brake lines.***

These permanent baseplate safety cables should remain installed as long as the baseplate is installed on the vehicle. Permanent baseplate safety cables are to be used in conjunction with, and NOT a replacement for legally required safety cables attaching the towed vehicle to the towing vehicle.

### OPTION #1

Permanent Baseplate Safety Cables to Cross Member or Frame of Towed Vehicle.

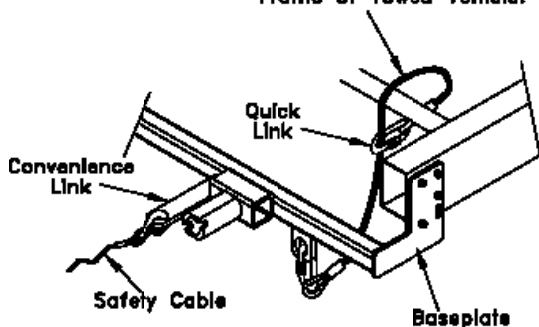

### OPTION #2

Permanent Baseplate Safety Cables to Cross Member or Frame of Towed Vehicle.

