



Baseplate Installation Instructions

BX1303 2002-06 BMW Mini Cooper 2006-08 BMW Mini Cooper Convertible Manual Transmission Only Installation Instructions

Serial Number

Please read BOTH these Installation Instructions and the General Towing Instructions before attempting to install or operate this equipment.

1. Blue Ox® towing products and accessories are intended to be installed by Blue Ox® Dealers who are familiar with our products and have the equipment and knowledge to do “fit work.” When necessary, Blue Ox® Dealers can be found at www.blueox.us or by contacting our Customer Care Department at (888) 425-5382.

Attachment Tab Height: 10 1/2”

Attachment Tab Width: 18”

2. Many Blue Ox® Baseplates are designed to use existing holes and hardware to mount the baseplate to the towed vehicle. Even though bolts are there, do not assume they are adequate for baseplate mounting. Always use hardware supplied in the hardware kit or existing hardware specified in the Baseplate Towing Installation Instructions.

Bolt Torque Specifications

Torque in Foot-Pounds for Metric Bolts

Bolt Size	Grade 8.8	Grade 10.9
6MM	6	8
8MM	16	22
10MM	31	40
12MM	54	70
14MM	89	117

Confirm the towability and pre-towing procedures for your vehicle with the owner’s manual or contact the vehicle’s manufacturer for specific towing procedures.

Bolt Torque Specifications

Torque in Foot-Pounds for Inch Bolts

Bolt Size	Grade 5	Grade 8
1/4”	10	14
5/16”	19	29
3/8”	33	47
7/16”	54	78
1/2”	78	119
5/8”	154	230



! WARNING

Failure to read and follow these instructions could result in separation of the towed vehicle from the tow bar, causing property damage, loss of towed vehicle, personal injury or death.

BX1303
 2002-06 BMW Mini Cooper
 2006-08 BMW Mini Cooper Convertible
 Installation Instructions

Parts List

Ref. No.	Qty.	Part #	Description
1	1	61-6132	Base Plate, BX1303
2	2	62-3468	Attachment Assembly, SF/SB (R)
3	2	201-0192	#10-32 x 1/2 Slot, Round Head Screw
4	2	201-0979	#12-14 x 1" Self Drilling Screw, ZP
5	2	202-0047	#10-32 Hex Nut
6	2	203-0054	#10 Lock Washer
7	1	229-0685	Electrical Bracket, ZP
8	4	Existing	Metric Nuts
9	2	226-0046	Baseplate Safety Cable, 36" Class III (Not Shown)
10	2	229-0359	Quicklink, 3/8, ZP (Not Shown)
11	2	290-0275	8 Inch Nylon Cable Tie (Not Shown)
12	2	290-0437	Receiver, Cap Plug (Blk) (Not Shown)

Tools Required

8MM Socket	Loctite Red
10MM Socket	3/8" Socket
13MM Socket	Reciprocating Saw
Utility Knife	30 Torx
Vise Grips	Phillips Screw Driver

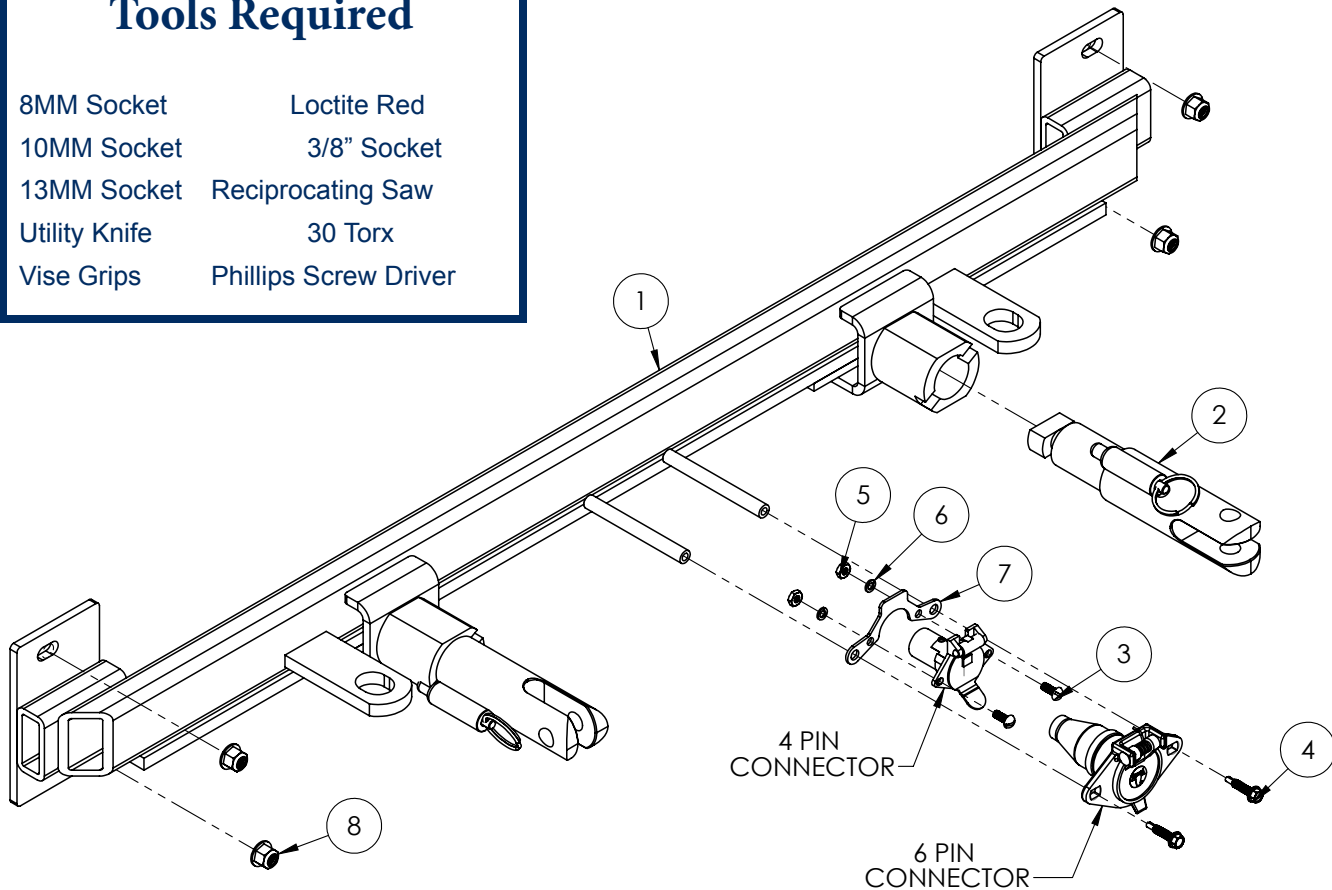

Important:

Use only genuine factory replacement parts on your baseplate. Do **NOT** substitute homemade or non-typical parts. If a bolt is lost or in need of replacement, for your safety and the preservation of your baseplate, be sure to use a replacement bolt of the same grade (In most cases it will be Grade 5, please reference the parts list above). Replacement parts may be ordered through your nearest Blue Ox® Dealer or Distributor.

BX1303
2002-06 BMW Mini Cooper
2006-08 BMW Mini Cooper Convertible

Installation Instructions

Vehicle Weight:

Motorhome mount tow bars are recommended for use with this baseplate. Due to the design of the removable tabs, the RangeFinderII, Adventurer, and Ambassador tow bars can not be used. The Acclaim tow bar may be used, but will not fold and store on the front of the vehicle. Adapters, except the BX8833 and BX88151, can not be used with this baseplate.

Installation Notes: The front fascia is removed for baseplate installation. There are no holes to drill. Some models will need to have the mesh in lower grill opening trimmed to allow baseplate to come through.

The dimensional variations between otherwise identical vehicles can be considerable. While the baseplate was designed for easy installation, it may be necessary to tailor the baseplate slightly to compensate for auto manufacturer's tolerances. These minor adjustments may include filing a hole slightly, bending electrical rods and/ or bending end plates.

The BX8869 Bulb and Socket Wiring Kit is recommended for the 2002-06 BMW Mini Cooper. The BX8848 4-Diode Wiring Kit is recommended for the 2007 BMW Mini Cooper convertible.

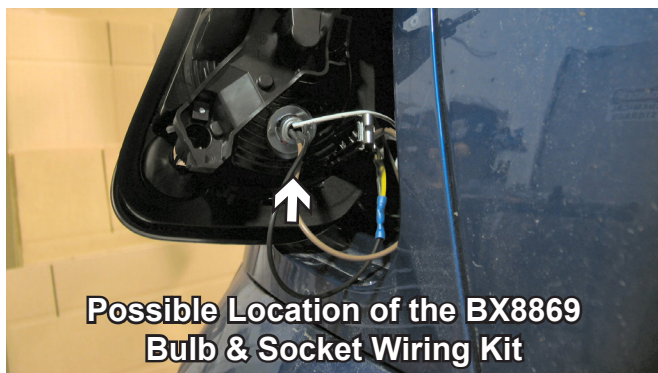

Installation Instructions:



1. Using the 30 Torx, remove the bolts from the top side of fascia.



2. Just forward of front tire, on wheel well, are two phillips head push pins to remove, on both sides.



3. Locate opening in wheel well just forward of front tire, remove two metric bolts with the 8MM socket, on both sides.

BX1303
2002-06 BMW Mini Cooper
2006-08 BMW Mini Cooper Convertible
Installation Instructions



4. Remove the two Phillips screws from the lower edge of front fascia, on both sides.

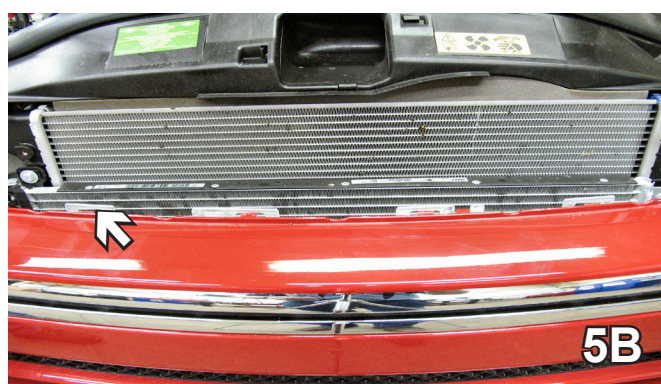
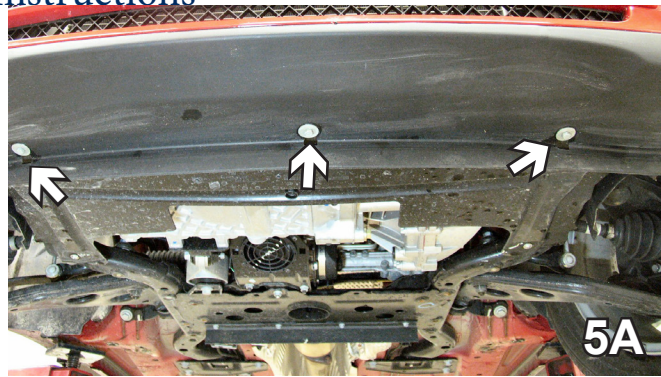

5. Remove three metric bolts from the lower edge of front fascia with the 10MM Socket. Release the four clips on the top edge of fascia, pull fascia forward, unplug all electrical connections and set fascia aside carefully.

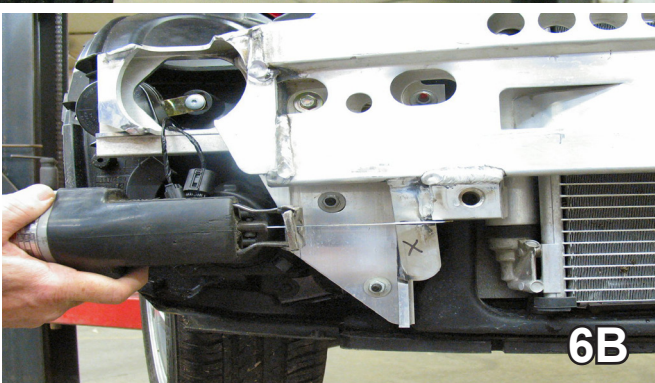
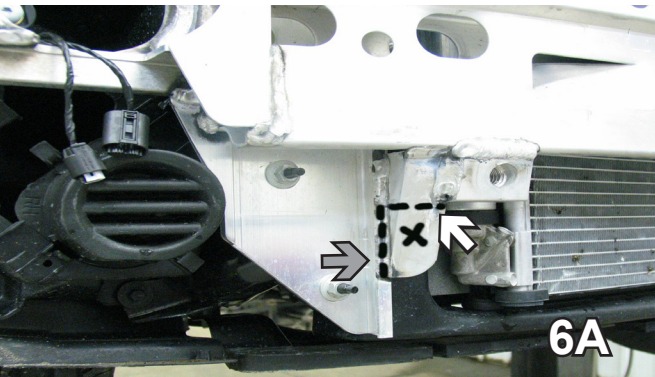

6. Locate tow plate bracket on passenger's side of front bumper. Mark and remove lower gusset just below tow plate bracket with the reciprocating saw, as shown in photos above. This will open area to allow baseplate installation.

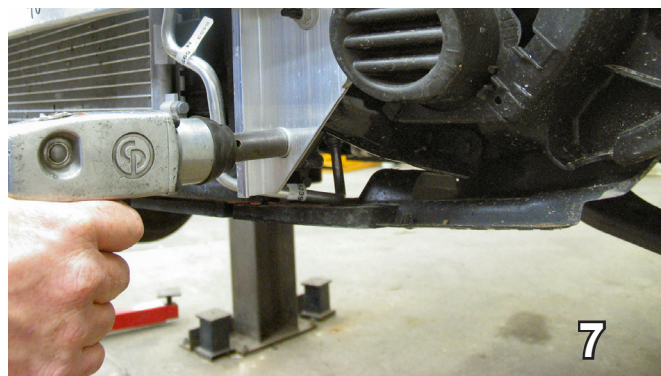

7. Remove the two metric hex nuts just below metal bumper with the 13MM socket, on both sides.

Using a good quality paint, spray cut edges of frame to prevent rusting.

BX1303
2002-06 BMW Mini Cooper
2006-08 BMW Mini Cooper Convertible
Installation Instructions

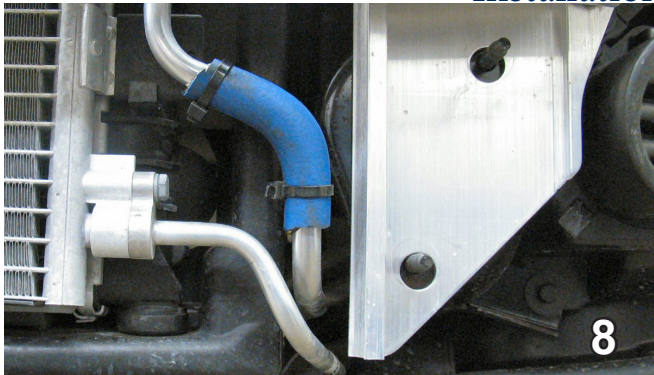

8. Using a utility knife, make a slit the length on blue 3/8" tubing, wrap the tubing onto driver's side upper coolant line as shown. Secure the tubing to the line with zip ties. This will protect coolant line from rubbing against the back of baseplate.

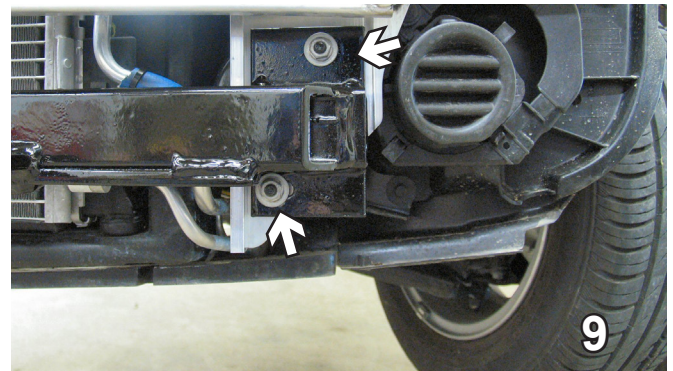

9. Align holes of baseplate with studs just below metal bumper and reinstall four existing nuts. **Be sure and use loctite on all threads before tightening. Tighten all nuts 16 ft/lbs.**

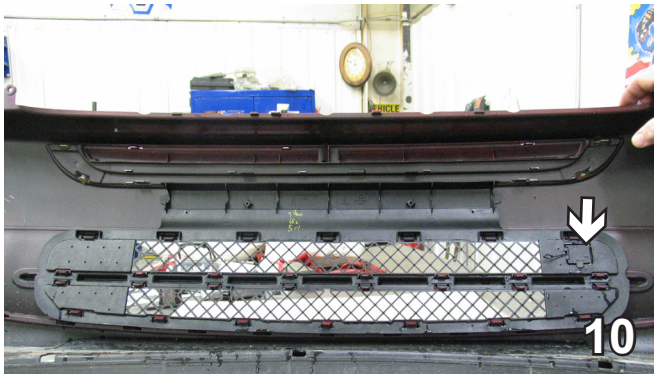

10. Hold fascia as close to its original location as possible on the vehicle. Mark and trim lower grill around the convenience links and attachment tabs. Reinstall fascia. **Be sure all electrical components are plugged in properly.**

NOTE: Optional Lower Grill Removal:

Set fascia face down on a soft surface to protect fascia front, release the grill clips (See photo) and set lower grill aside (Lower grill will not be reinstalled).

Be sure that **ALL** electrical connections are plugged in properly and functioning **BEFORE** installing the fascia.

DEALER or INSTALLER:
Be certain the user receives the instruction sheets for their products.

11. The dimensional variations between otherwise identical cars can be considerable. While the baseplate was designed for easy installation, it may be necessary to tailor the baseplate slightly to compensate for auto manufacturers' tolerances. These minor adjustments may include filing a hole slightly, bending electrical rods, adding shims and/or bending endplates.
12. Install the tow bar and safety cables according to the instructions included in their packages.
13. Do **not** substitute other devices if the tow bar pin and clip are lost.

BX1303
2002-06 BMW Mini Cooper
2006-08 BMW Mini Cooper Convertible
Installation Instructions

If the baseplate is in an accident, it must be replaced. DO NOT use it again! An accident can cause unseen damage and using it again could result in more damage or serious injury. DO NOT use the baseplate if it is damaged or missing parts.

CUSTOMER SERVICE COMMITMENT

Blue Ox® is committed to providing you with exceptional customer care throughout your lifetime with our products. Our team is here to assist you with any questions you may have regarding the performance of your product. Simply call (402) 385-3051 and you can speak with our customer care team.

Additionally, please visit our website to see which rallies our Destination America team will be attending. For a nominal fee, our service technician will service your towing system to ensure it's in proper working condition. Also, as a commitment to our customers, should you visit our factory, you can stay at our full service Blue Ox® campground at no charge along with enjoying a factory tour.

Again, thank you for being our customer and for the confidence you have shown in the performance of our products. It is because of customers like you we enjoy the success we have today.

© 2013 Blue Ox
One Mill Road, Industrial Park
Pender, Nebraska 68047
Phone: (402) 385-3051
Fax: (402) 385-3360
www.blueox.com

General Information

1. Ensure that your product(s) are registered online at www.blueox.com. It is crucial to register your product(s) so that you may be alerted of product offerings, updates, upgrades, maintenance and safety bulletins, and/or recalls.
2. **It is the owner's responsibility to inspect all towing equipment for cracked welds, missing or worn parts and loose bolts before each towing trip.** Be sure to use Loctite® Red on all bolts and tighten to the recommended specifications.
3. **It is the owner's responsibility to hook up all towing equipment per manufacturer's instructions/recommendations.**
4. Remove the attachment tabs when not in use (if applicable).

Notice To Baseplate Installer

1. **It is YOUR responsibility to watch for:**

- Oil cooler and air conditioner lines
- Electrical wires and hoses
- Missing parts or attaching points on the frame

** If the baseplate is improperly installed and is against a wire or hose, it could cause fluid leaks or electrical shorts some time after the actual baseplate installation.

Permanent Baseplate Safety Cable Installation

Permanent baseplate safety cables are strongly recommended when towing a vehicle with a tow bar. The principle function of the permanent baseplate safety cables is to prevent the towed vehicle from breaking loose in the event the connection between the frame of the towed vehicle and the baseplate fails or becomes disconnected. The cables must be connected from the baseplate to the frame rail or cross member of the vehicle's frame. The illustrations below show the possible arrangements recommended by Blue Ox®. Each permanent baseplate safety cable must have an adequate weight rating for the towing system. The weight rating of the two (2) cables together will not qualify.

Do not mount the permanent baseplate safety cables against wires, hoses or brake lines.

These permanent baseplate safety cables should remain installed as long as the baseplate is installed on the vehicle. Permanent baseplate safety cables are to be used in conjunction with, and NOT a replacement for legally required safety cables attaching the towed vehicle to the towing vehicle.

OPTION #1

Permanent Baseplate Safety Cables to Cross Member or Frame of Towed Vehicle.

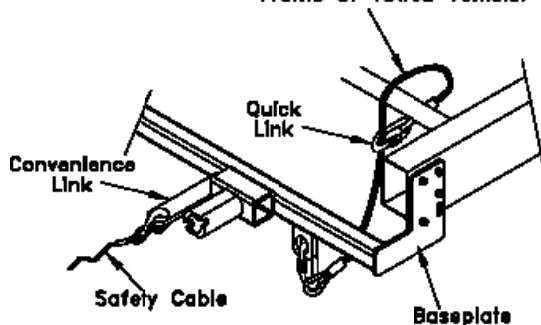

OPTION #2

Permanent Baseplate Safety Cables to Cross Member or Frame of Towed Vehicle.

