



**BLACK HORSE  
OFF ROAD**

## **INSTALLATION INSTRUCTIONS**

**BULL BAR**

**2014-2016 TOYOTA HIGHLANDER**

**PART # MAB-TOF5307S**

**PARTS LIST:**

1	Bull Bar	2	12-1.75mm x 35mm Hex Bolts
1	Driver/Left Mounting Bracket	8	12mm x 32mm OD x 3mm Flat Washers
1	Passenger/Right Mounting Bracket	2	12mm Lock Washers
1	Driver/Left Support Bracket	4	12mm Nylon Lock Nuts
1	Passenger/Right Support Bracket	2	10-1.25mm x 35mm Hex Bolts (fine thread)
2	12-1.75mm x 90mm Bolt Plates	2	10mm x 27mm OD x 3mm Flat Washers
2	12-1.75mm x 45mm Hex Bolts	2	10mm Lock Washers

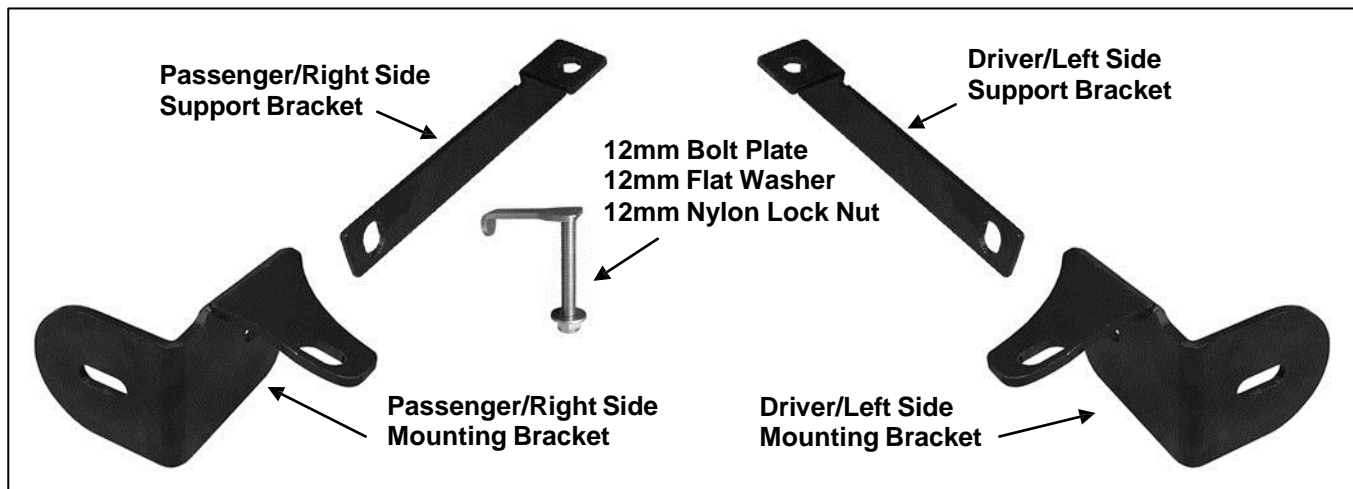

**PROCEDURE:**

- REMOVE CONTENTS FROM BOX. VERIFY ALL PARTS ARE PRESENT. READ INSTRUCTIONS CAREFULLY BEFORE STARTING INSTALLATION. ASSISTANCE RECOMMENDED. CUTTING IS REQUIRED. INSTALLATION MAY INTERFERE WITH FRONT BUMPER MOUNTED PARKING SENSORS OR GRILLE MOUNTED CRUISE CONTROL SENSORS.**
- Remove the front plastic splash guard from under the front bumper, **(Figure 1)**.
- Remove the plastic plugs covering the holes through the top and bottom of the crossmember on the driver and passenger side, **(Figures 2 & 3)**.
- Select (1) 12mm x 90mm Bolt Plate. Insert the Bolt Plate down through the crossmember from the top, **(Figures 4A & 4B)**.
- Select the passenger side Mounting Bracket, **(Figure 5A)**. Locate the two factory bolts on the crossmember brace leading towards the bumper, **(Figures 4B & 5B)**. Remove the factory hex bolt towards the outside of the vehicle. Position the driver side Mounting Bracket up to the bottom of the crossmember brace. Bolt the Mounting Bracket in place on the bottom of the brace using the included (1) 10-1.25mm x 35mm Fine Thread Hex Bolt, (1) 10mm Lock Washer and (1) 10mm Flat washer, **(Figure 5B)**. Snug but do not tighten hardware at this time.
- Select the passenger side Support Bracket, **(Figure 6A)**. Attach the end with the bent tab to the Bolt Plate, (see **Step 4**), with the included (1) 12mm x 32mm STD Flat Washer and (1) 12mm Nylon Lock Nut, **(Figure 6B)**. Attach the flat end of the Support Bracket to the inside of the Mounting Bracket using the included (1) 12mm x 30mm Hex Bolt, (2) 12mm Flat Washers and (1) 12mm Nylon Lock Nut, **(Figure 7)**. Do not tighten hardware at this time. .
- With assistance, position the Bull Bar up to the Mounting Brackets. Attach the Bull Bar to the Mounting Brackets using the included (2) 12mm x 45mm Hex Bolts, (2) 12mm Lock Washers and (2) 12mm Flat Washers, **(Figure 7)**.
- Level and adjust the Bull Bar properly and tighten the (2) 10mm Hex Bolts attaching the Mounting Brackets to the crossmember only at this time. Temporarily remove the Bull Bar and Support Brackets.
- Hold the factory plastic splash guard up in its original mounting position and trace the location of the (2) Mounting Brackets and the (2) Bolt Plates onto the inside of the splash guard, **(Figure 8)**. Use a sharp knife or hacksaw blade to cut out the traced area for the Mounting Brackets. **IMPORTANT:** To maintain

strength in the splash guard, only remove necessary material to clear the Mounting Brackets. Next, use a 1/2" drill bit or a sharp knife to open a hole for the threaded end of the (2) Bolt Plates to go through as described in **Step 4**.

10. Temporarily re-install the splash guard using the factory hardware. Check the fit of the Support Brackets and the ends of the Bull Bar and trim the splash guard as required. Once properly fit, fully install the splash guard.
11. Reinstall the Support Brackets over the splash guard.
12. Reinstall the Bull Bar.
13. Do periodic inspections to the installation to make sure that all hardware is secure and tight.

**To protect your investment**, wax this product after installing. Regular waxing is recommended to add a protective layer over the finish. Do not use any type of polish or wax that may contain abrasives that could damage the finish.

**For stainless steel:** Aluminum polish may be used to polish small scratches and scuffs on the finish. Mild soap may be used also to clean the Bull Bar.

**For gloss black finishes:** Mild soap may be used to clean the Bull Bar.

### Passenger Side Installation Pictured

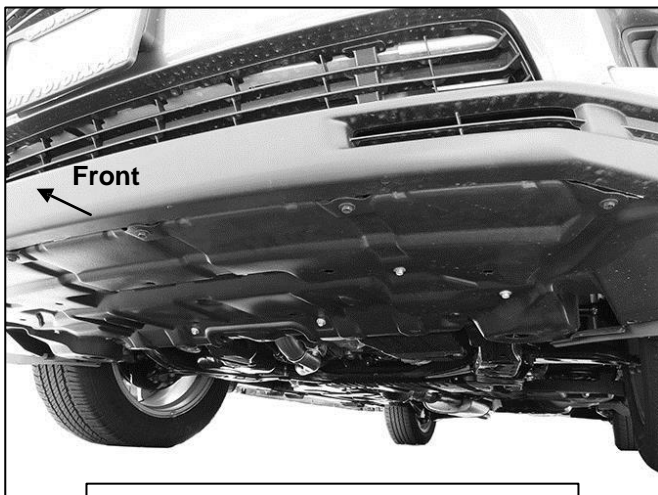

(Fig 1) Remove plastic splash guard

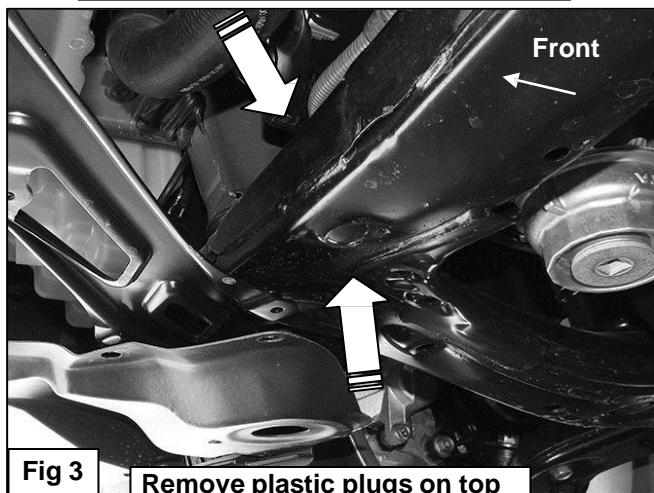
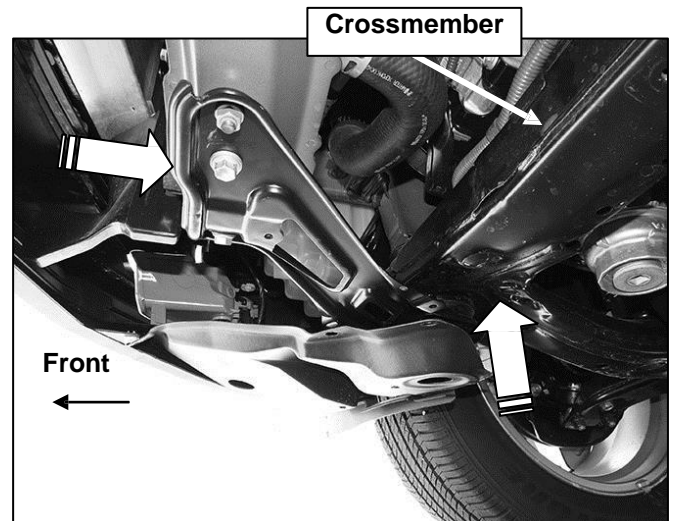
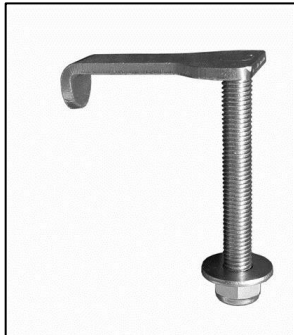

Fig 3 Remove plastic plugs on top and bottom of cross member



(Fig 2) Passenger side mounting location (arrows)

Passenger Side Installation Pictured



(Fig 4A) 12mm Bolt Plate

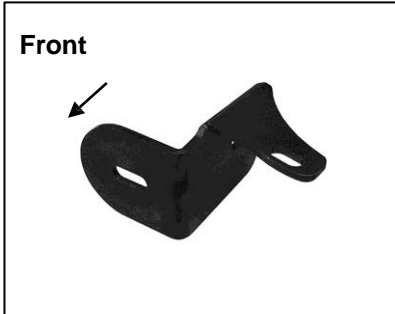

(Fig 5A) Passenger Frame Bracket

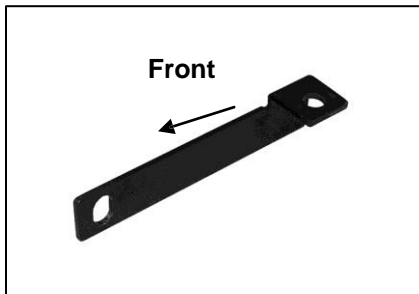

(Fig 6A) Passenger Support Bracket

12mm x 35mm Hex Bolt  
(2) 12mm Flat Washers  
12mm Nylon Lock Nut

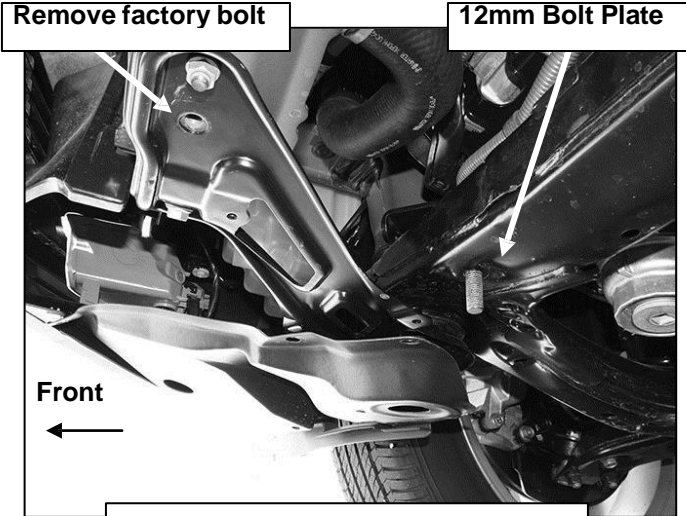

(Fig 4B) Insert Bolt Plate down through holes in cross member

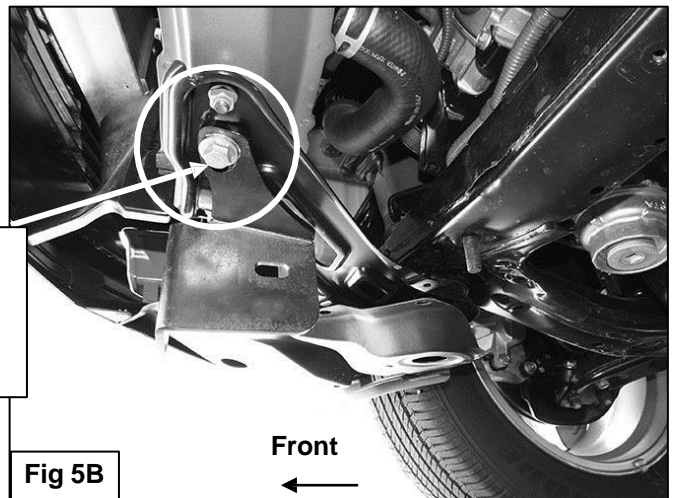

Fig 5B

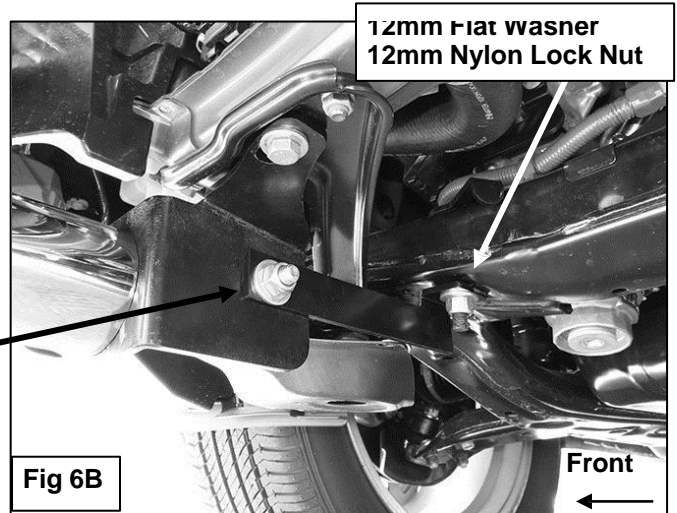
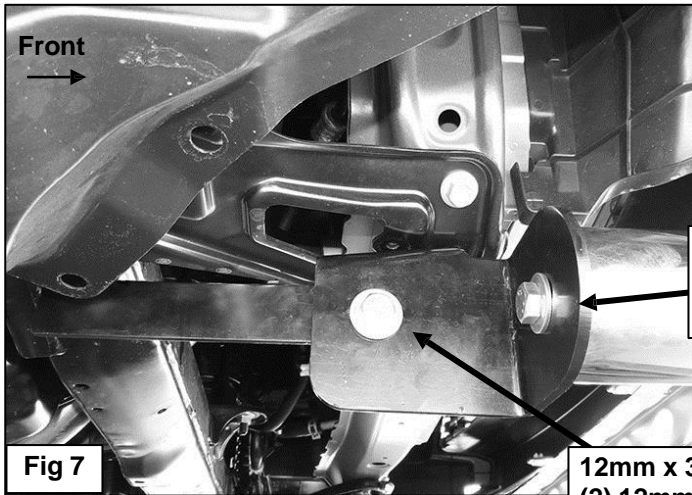

Fig 6B

**Passenger Side Installation Pictured**



(2) 12mm x 45mm Hex Bolts  
(2) 12mm Lock Washers  
(2) 12mm Flat Washers

12mm x 35mm Hex Bolt  
(2) 12mm Flat Washers  
12mm Nylon Lock Nut

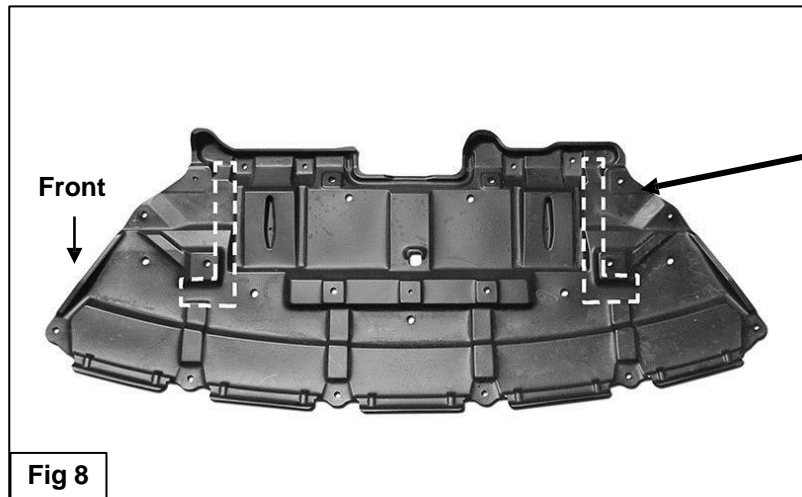

Hold the splash guard up to the bottom of the Brackets. Trace the location of the Brackets onto the inside of the splash guard. Cut (2) openings through splash guard for Mounting Brackets (illustrated for example only. Actual cut out area may differ according to model and year)

Do not cut off mounting points if at all possible

