



Installation Instructions Trektop Halftop Kit

Vehicle Application:
Jeep® Wrangler JK 2007-2018
Part Number 80102

Installation Tips

Before you begin installing your new Trektop Halftop Kit, please read all the instructions thoroughly.

For easier installation, the top should be installed at a temperature above 72°F. Below this temperature, the fabric may contract an inch or more, making it difficult to fit the vehicle.

It is normal for the fabric to contract and wrinkle when stored in the shipping carton. Within a few days after installation, the fabric will relax and the wrinkles will disappear.

WARNING Do not rely in any way on the components of this product to protect against injury or death in the event of an accident. Never operate the vehicle in excess of manufacturer’s specifications.

Read and follow, precisely, all installation instructions provided when installing this product. Failure to do so may result in a poor fit and could place occupants of the vehicle in a potentially dangerous situation.

WEAR SEAT BELTS AT ALL TIMES

CAUTION Safety glasses should be worn at all times when installing this product.



Tools



Safety Glasses

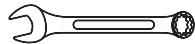

10mm and 13mm Wrench



4mm Hex Key

Installation Time

1 00 1 Hour

Skill Level

1 2 3 4

2 - Moderatly Easy

Support

We’re here to help! Go to:
<https://www.bestop.com>
and click on **Need Help?**



<https://www.bestop.com/video-library>



Installation Instructions Trektop Halftop Kit

Vehicle Application:
Jeep® Wrangler JK 2007-2018
Part Number 80102

Sugerencias de Instalación

Antes de empezar a instalar esta unidad, lea atentamente todas las instrucciones.

Para un buen ajuste:

Para facilitar la instalación, el producto debe instalarse a temperaturas superiores a 72 °F (22 °C).

Por debajo de esta temperatura, la tela puede encogerse una pulgada o más, lo que dificultaría su ajuste al vehículo.

Es normal que la tela se contraiga o arrugue cuando está guardada en la caja de empaque. A los pocos días después de la instalación, la tela se relajará y las arrugas desaparecerán.



ADVERTENCIA

Este producto se diseñó principalmente para mejorar la apariencia del vehículo y proteger a los ocupantes de las condiciones climáticas comunes. De ninguna manera piense que los componentes de este producto pueden servir como medio de contención para los ocupantes del vehículo o que pueden protegerlos contra lesiones o la muerte en caso de accidente. Este producto no protegerá a los ocupantes contra caídas de objetos. Nunca conduzca este vehículo fuera de las especificaciones del fabricante.

USE LOS CINTURONES DE SEGURIDAD EN TODO MOMENTO

Lea y siga con precisión todas las instrucciones de instalación que se proporcionan para instalar este producto. Si no lo hace, podría producirse un mal ajuste que colocaría a los ocupantes del vehículo en una situación potencialmente peligrosa.



PRECAUCIÓN

Debe usar gafas protectoras en todo momento durante la instalación de este producto.

Conseils pour l'installation

Lire toutes les instructions au complet avant de commencer l'installation de cet assemblage.

Pour un ajustement sans problème :

Afin de faciliter l'installation, ce produit doit être installé à des températures au-dessus de 72 °F (22 °C).

Sous cette température, le tissu peut rétrécir d'un pouce (2,5 cm) ou plus, ce qui rendra l'ajustement sur le véhicule difficile.

Il est normal que le tissu rétrécisse et plisse pendant qu'il est dans la boîte d'expédition. En quelques jours après l'installation, le tissu se détendra et les plis disparaîtront.



AVERTISSEMENT

Ce produit est conçu principalement pour améliorer l'apparence du véhicule et pour protéger les occupants des conditions météorologiques usuelles. Ne jamais se fier aux composants de ce produit pour se protéger de blessures ou de la mort en cas d'accident. Ce produit ne protégera pas les occupants des chutes d'objets. Ne jamais utiliser le véhicule au-delà des caractéristiques techniques indiquées par le fabricant.

PORTER UNE CEINTURE DE SÉCURITÉ EN TOUT TEMPS

Lire et suivre, très fidèlement, toutes les instructions d'installation fournies lors de l'installation de ce produit. Ne pas suivre cette consigne peut causer une installation inadéquate et mettre les occupants du véhicule dans une situation potentiellement dangereuse.



MISE EN GARDE

Des lunettes de sécurité doivent être portées en tout temps lors de l'installation de ce produit.



Installation Instructions Trektop Halftop Kit

Vehicle Application:
Jeep® Wrangler JK 2007-2018
Part Number 80102

Parts List

629.11 Kit

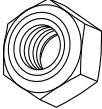

Nut, M6
Part #434.11
Qty. 6

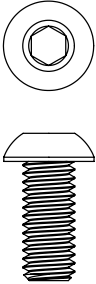

M6 X 14 Button Head Screw
Part #517.63
Qty. 6

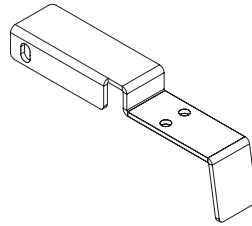

Lower Attach Bracket "C"
Pillar
Part # 621.02 Right (Shown)
Part # 621.03 Left
Qty. 1 Per Side

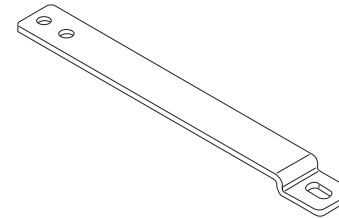

Upper Attach Bracket
Part # 621.05
Qty. 2



Bow C Pillar
Part #629.13
Qty. 2

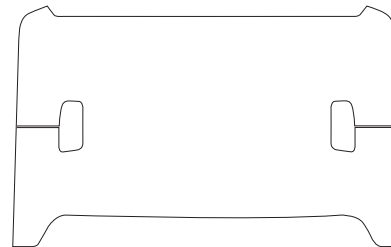

Duster Assembly

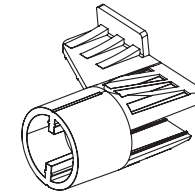

Plastic End Cap
Right
Part # 592.66
Qty. 1

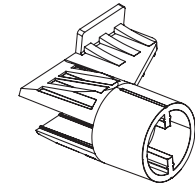

Plastic End Cap Left
Part # 593.71
Qty. 1

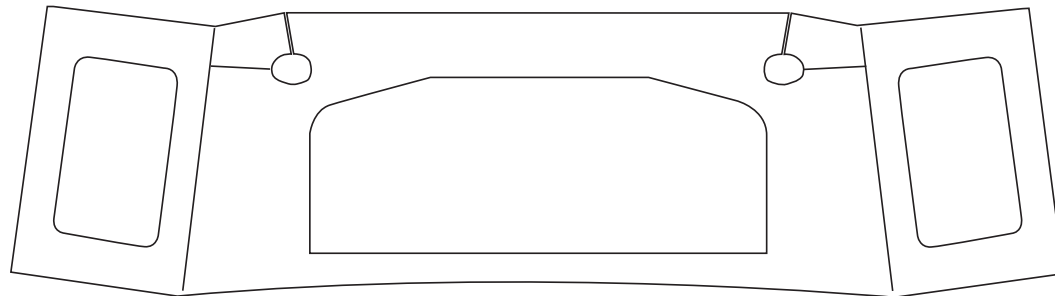

Windjammer Assembly

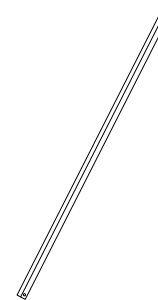

Windjammer Extrusion
Qty. 1
Part # 614.46

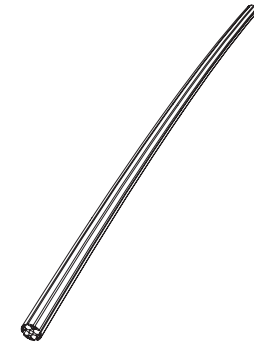

Extruded Aluminum Bow
Qty. 1
Part # 620.81

Fold back the rear corners of the top then open the tailgate.

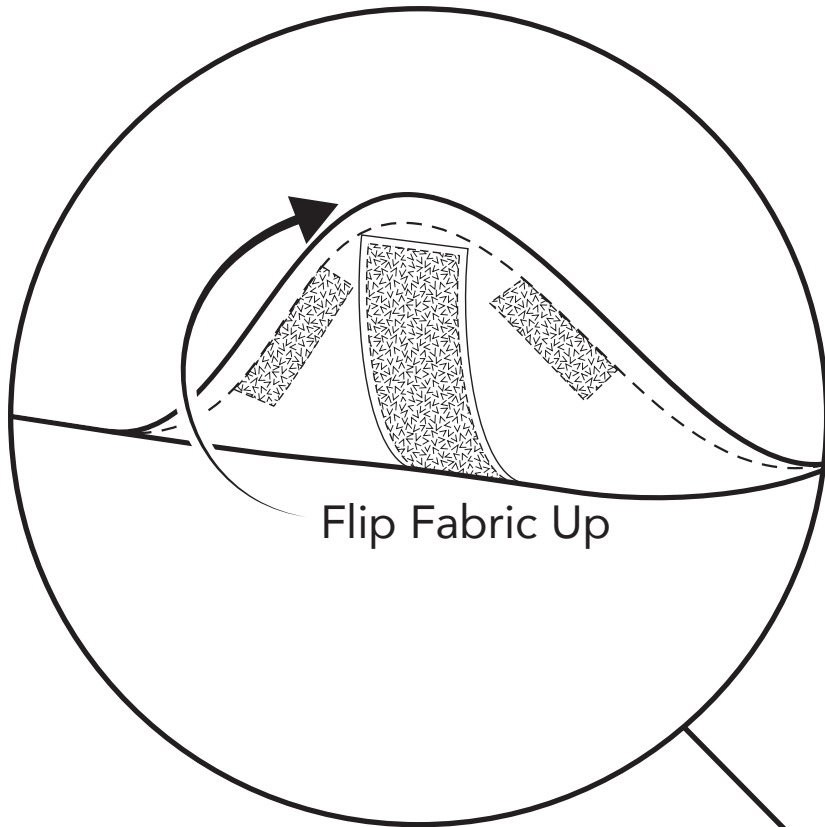

Pull the plastic retainer (Sewn to the lower corner of the Rear Window) out of the Tailgate Clip. Repeat this on the left side of the window.

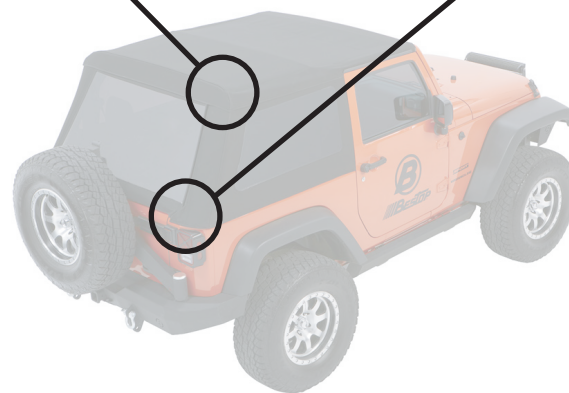
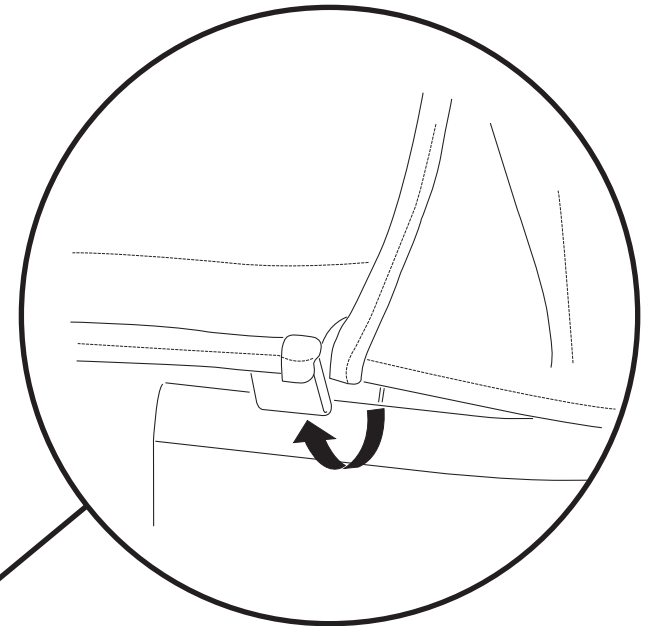

Un-zip both sides of the rear window.

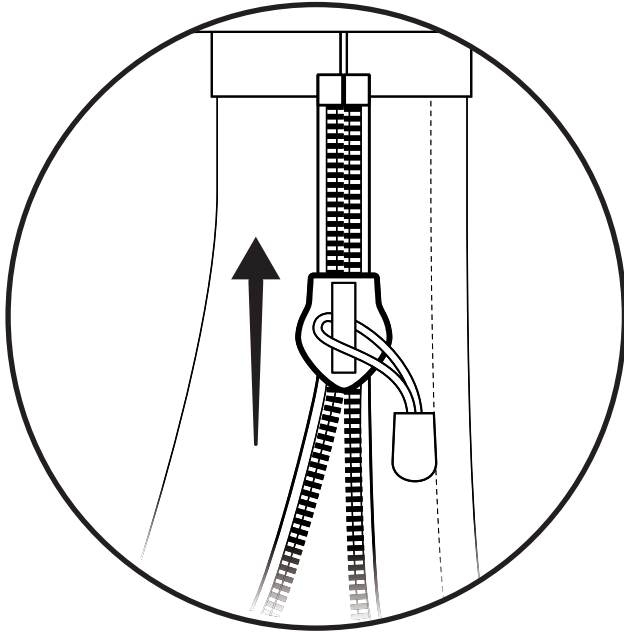

With Tailgate open, Pull the Tailgate bar from the Tailgate Clips on both sides.

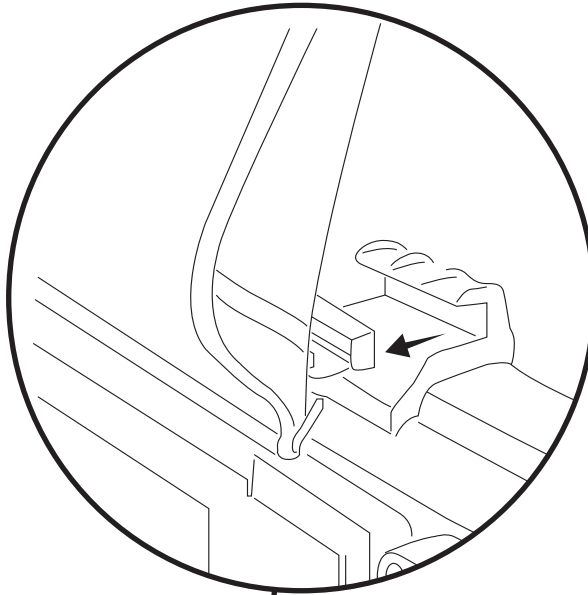

Slide the top of the window to the left to remove it from the vehicle.

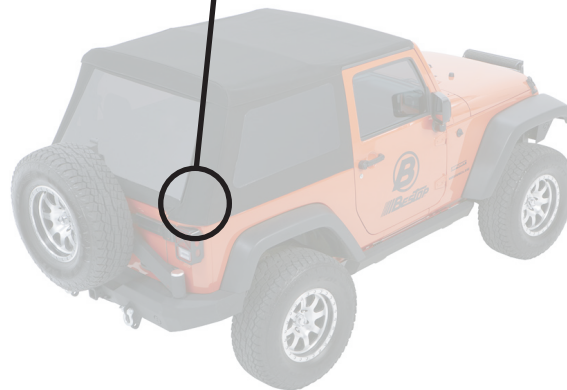
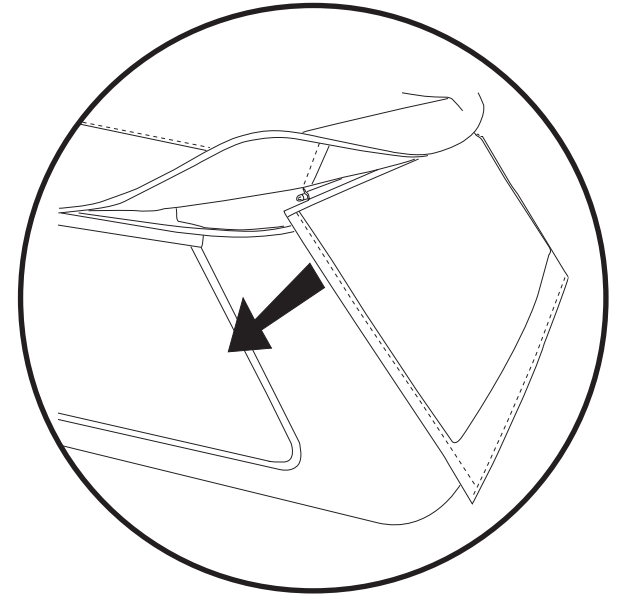

Unsnap the strap that connects the side panel to the Tailgate Bar Retainer. Repeat this step on the left side of the vehicle.

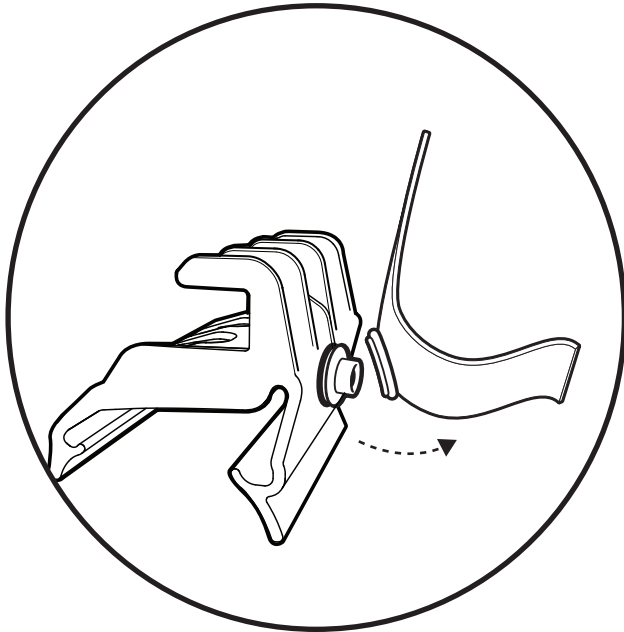

Remove the plastic retainers located along the bottom and front edge of the Side Panel from the body of the vehicle.

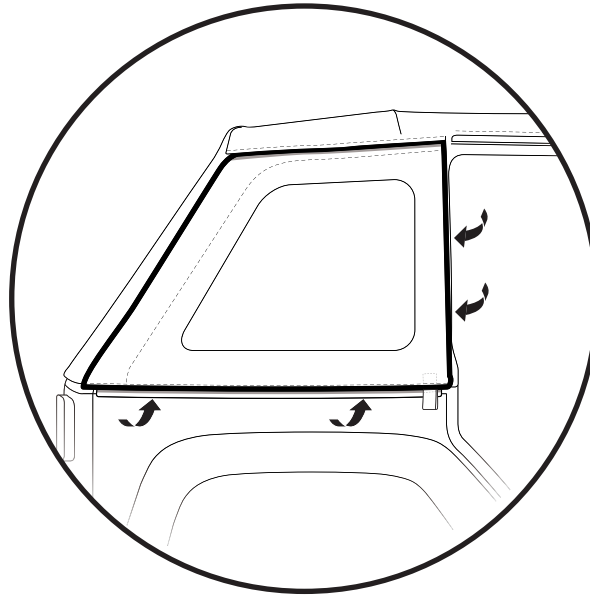

Slide the top of the window to the rear to remove it from the vehicle.

Repeat these three steps on the left side of the vehicle.

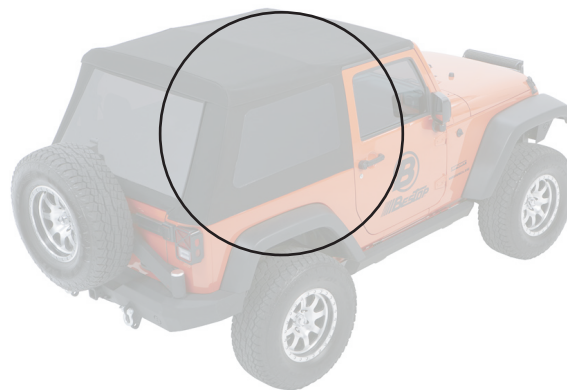
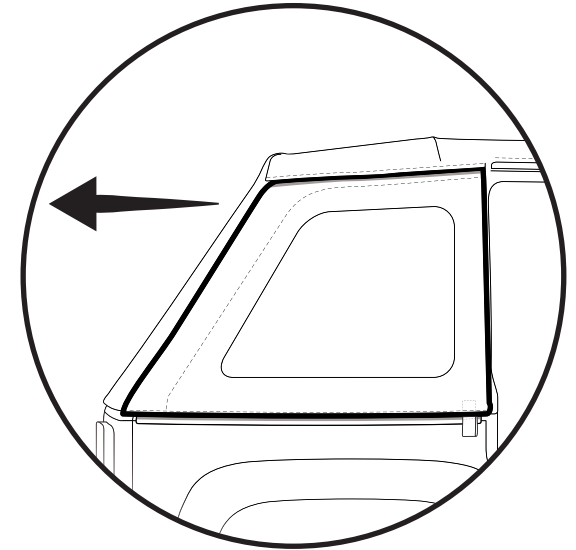

Fold the front section of the top back.

Pull cable from under the shoulder bolt on the Cable Guide Bracket.
Repeat on right side of vehicle.

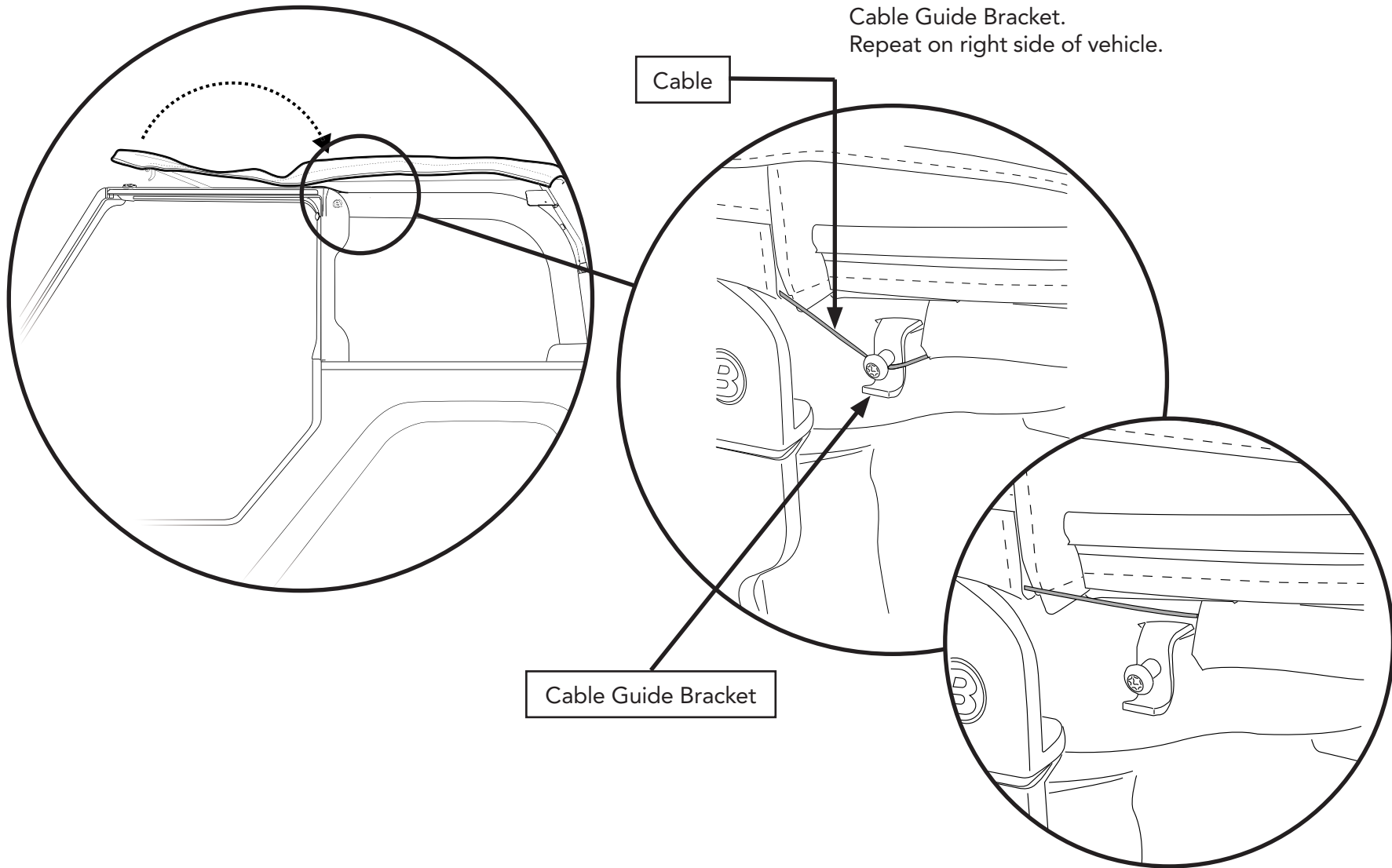

- ① Pull pin back.
- ② Pull knuckle out of the Pin Point Bracket.
Repeat on other side of vehicle.
Fold bow and fabric on top of the header.

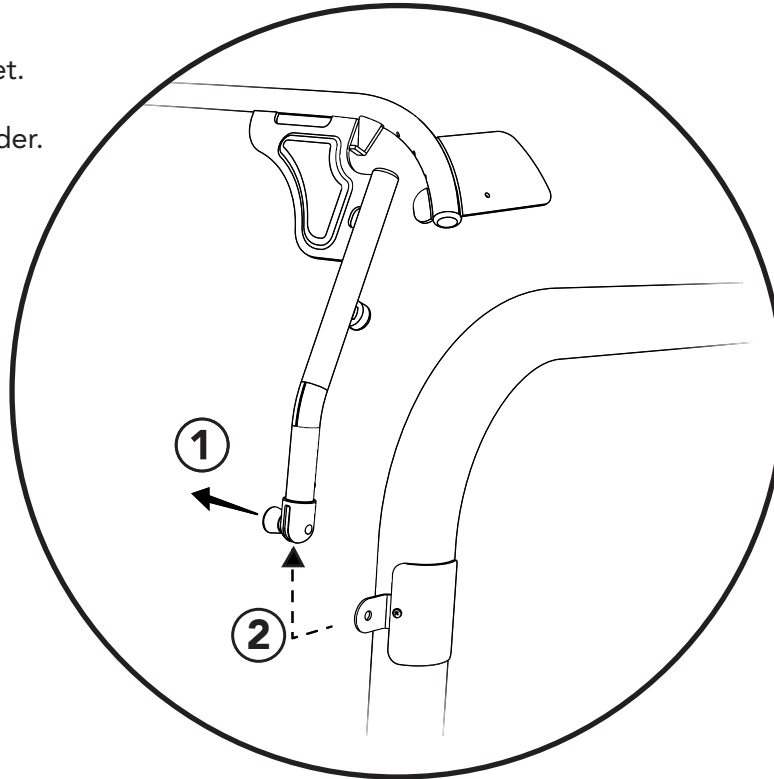

Tools

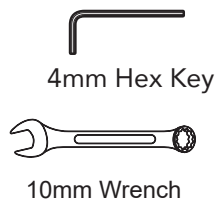

Parts

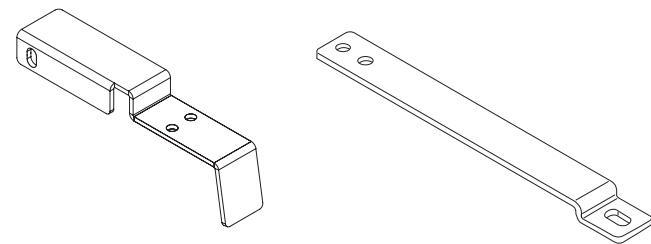

Lower Attach Bracket "C"
Pillar
Part # 621.02 Right (Shown)
Part # 621.03 Left
Qty. 1 Per Side

Upper Attach Bracket
Part # 621.05
Qty. 2

Assemble the Windjammer Extrusion, Upper Attach Bracket and Lower Attach Bracket "C" Pillar together using three M6 x 14 Button Head Screws and three M6 Nuts.

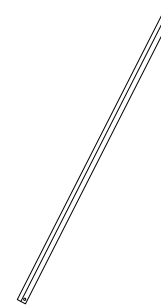
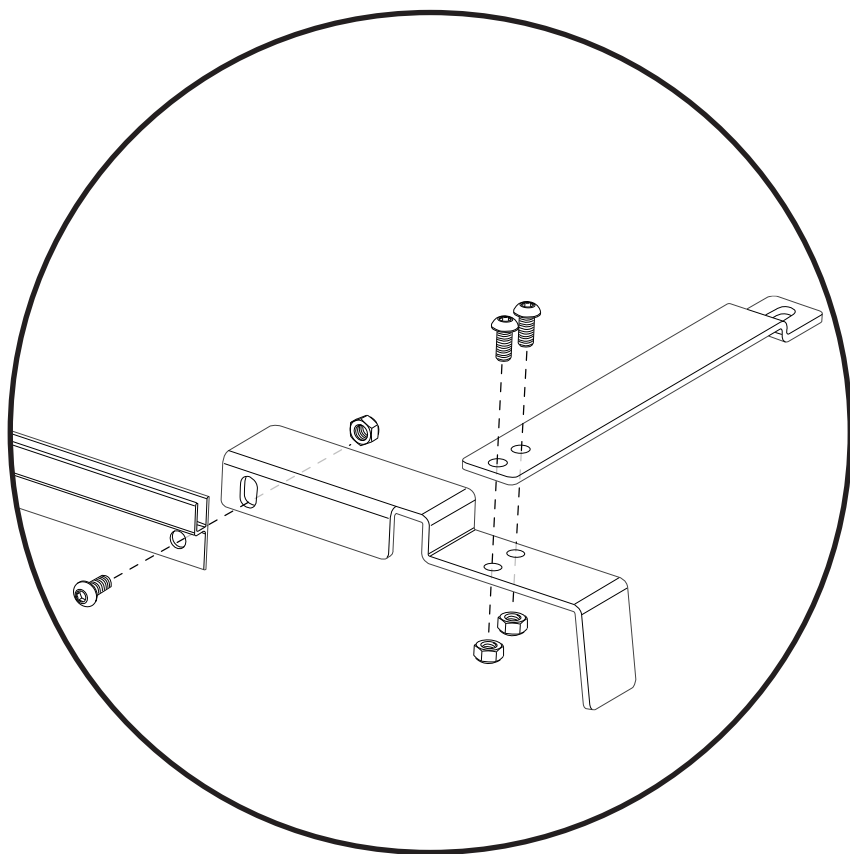

Windjammer Extrusion
Qty. 1
Part # 614.46



M6 X 14 Button Head Screw
Part #517.63
Qty. 6
4mm Hex Key

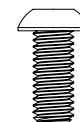

Nut, M6
Part #587.95
Qty. 6
10mm Wrench

You must cut a slit in the sportbar cover.

- ① Slide the zipper towards the outside of the of "the vehicle to clear the bolt head.
- ② Cut a slit in the fabric (Side to Side) 1" wide.

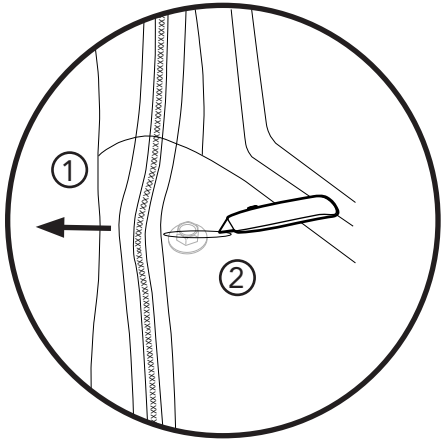

Unzip the sportbar cover. Remove the rear bolt from the factory sportbar.

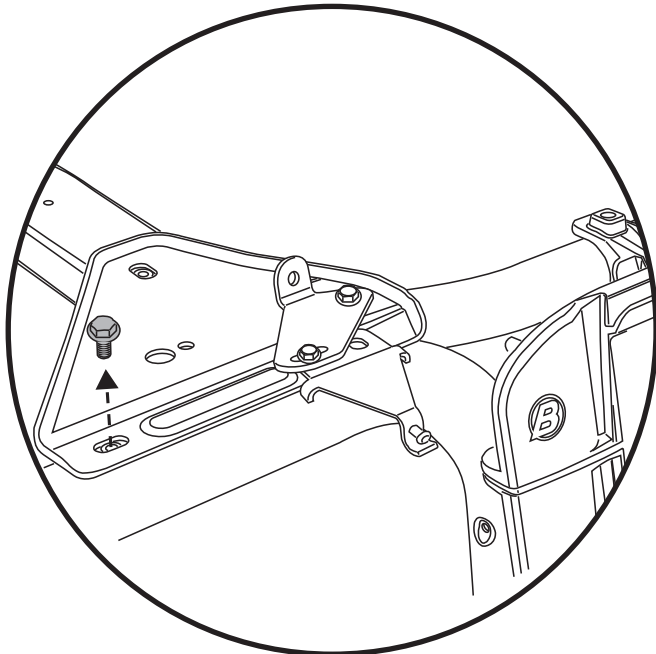

Tools



13mm Wrench



Utility Knife

Slide the upper support bracket through the slit in the sportbar cover. Place the Upper Support Brackets over the hole then replace the bolts. Zip the sportbar cover back up.

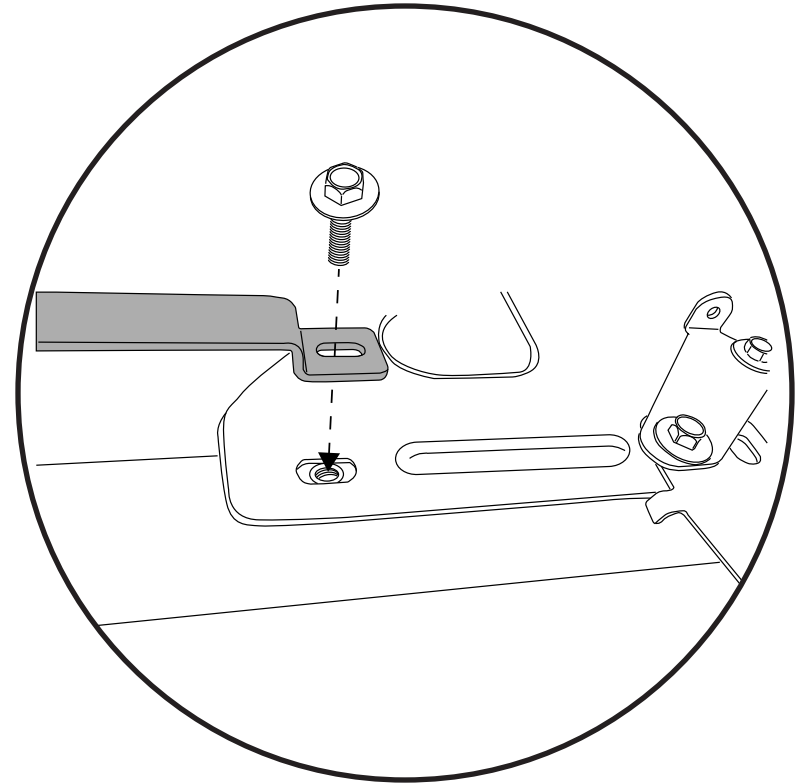

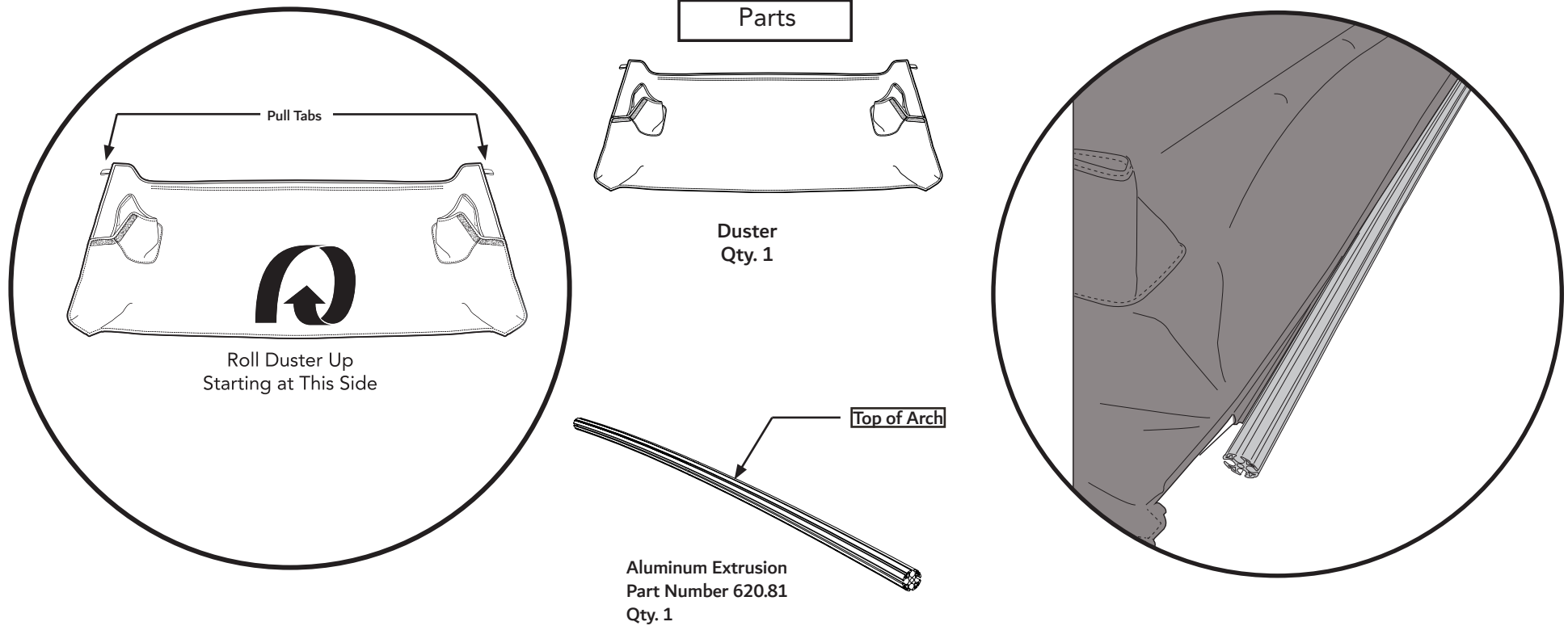

Starting on the side of the duster without the pull tabs, roll the Duster up loosely. The side of the Duster with the pull tabs is the front edge.

With the Duster loosely rolled up, slide the P-Extrusion along the exposed front edge of the Duster into the top slot of the Extruded Aluminum Bow, using the slot in the Bow that is on top of the arch and facing up.

NOTE: Aluminium Extrusion has arch. The Duster should be in the top part of the arch.

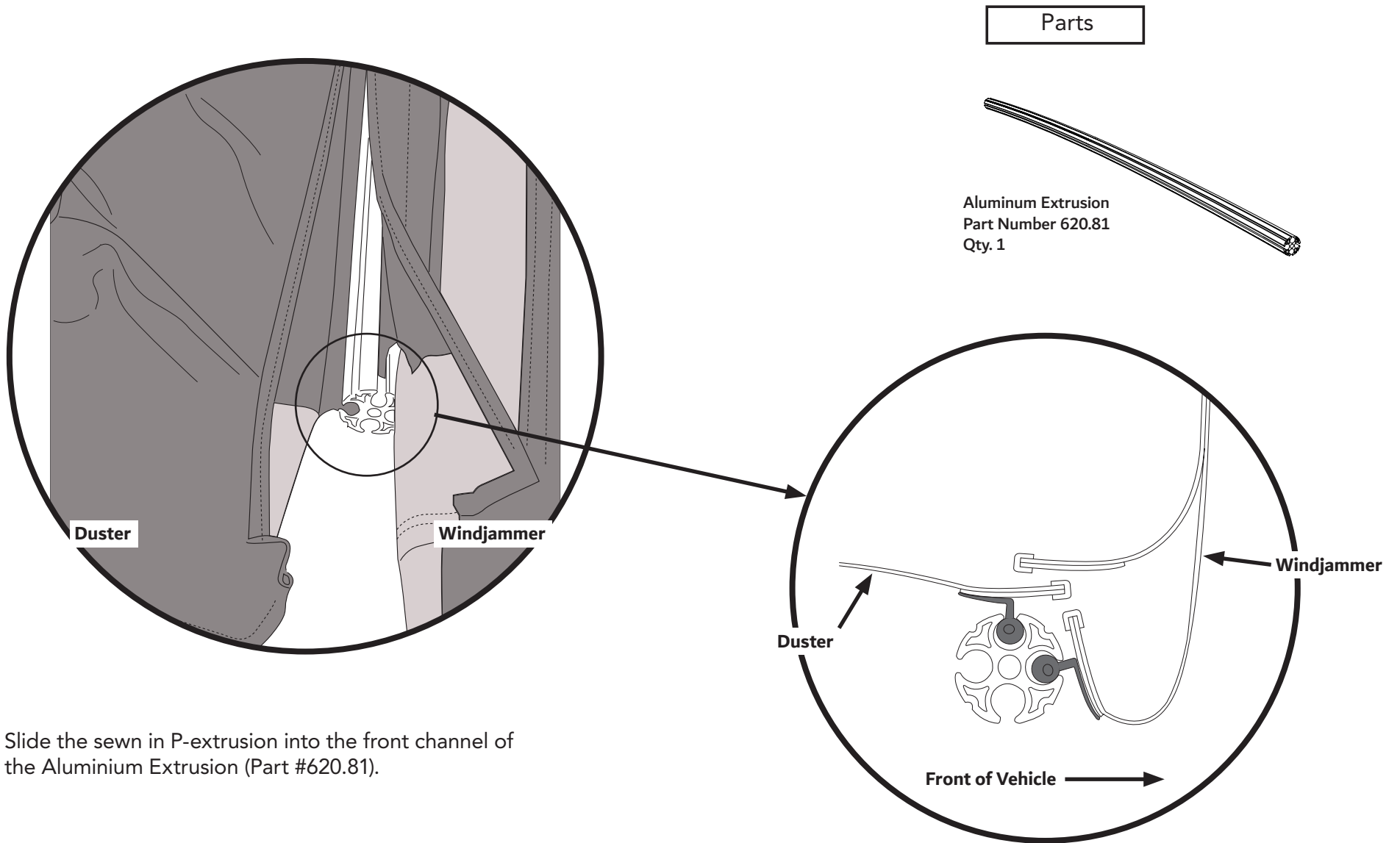

Slide the sewn in P-extrusion into the front channel of the Aluminium Extrusion (Part #620.81).

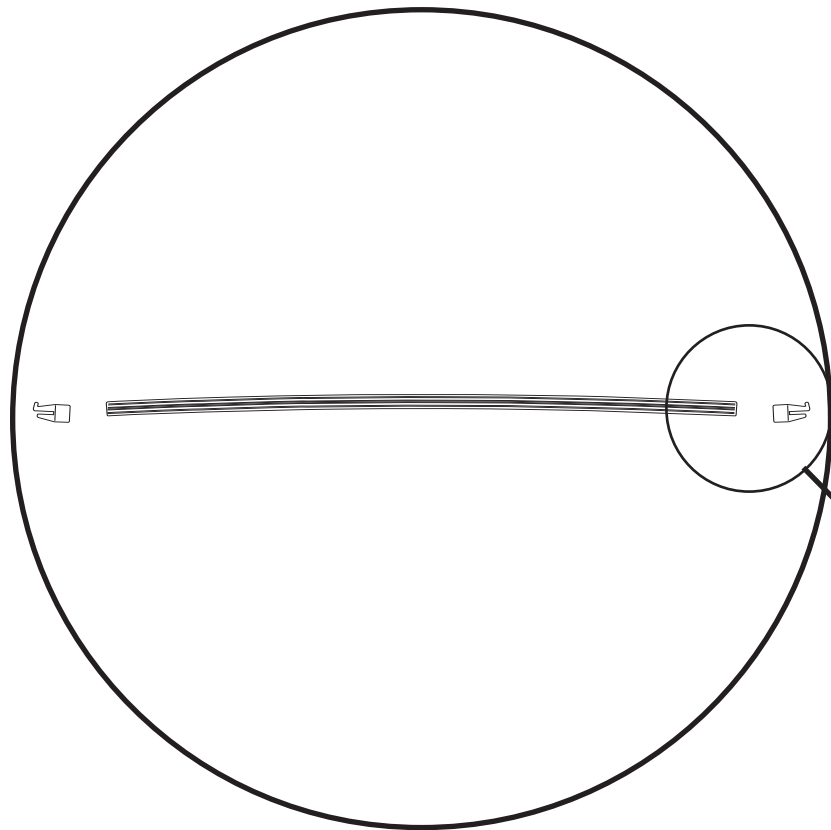

Place the Plastic End Caps (Part # 592.66) on the passenger side of the Aluminium Extrusion and (Part # 593.71) on the driver side.

The internal ribs inside the round opening of each end cap will slide into the slots on the top and bottom of the aluminum extrusion.

Parts

Plastic End Cap - Right
Bestop Part #592.66
Qty. 1

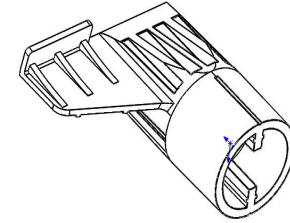

Plastic End Cap - Left
Bestop Part #593.71
Qty. 1

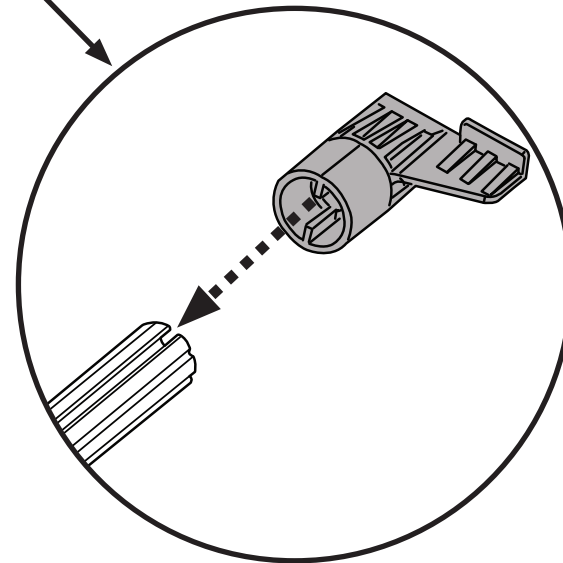
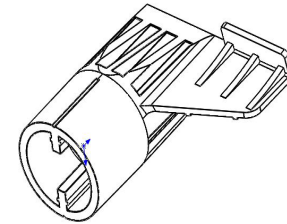

NOTE: The Wing must go towards the front of the vehicle with the Tab pointing up.

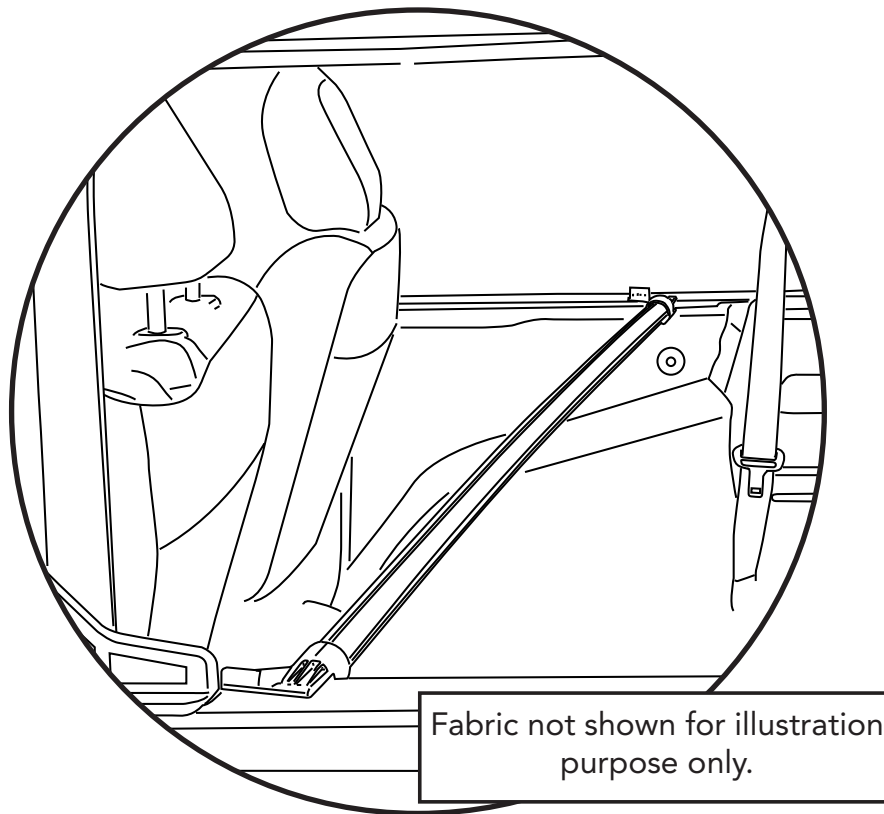

Fold the rear seat down. (Refer to Owners Manual)
Set End Cap as far rearward on the passenger side then set the other end cap as far forward as possible on the Driver side.

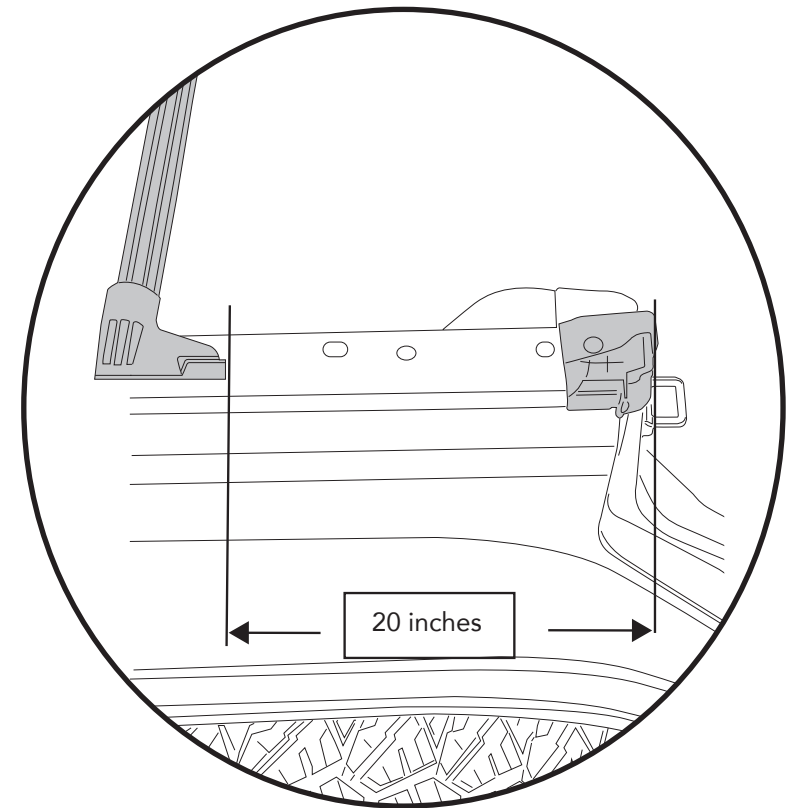

Slide the Bow End Rearward (Driver Side) and Forward (Passenger Side) until you reach the 20 inch dimension from the front of the Extrusion to the front edge of the Rubber Seal at the top and rear of the door opening.

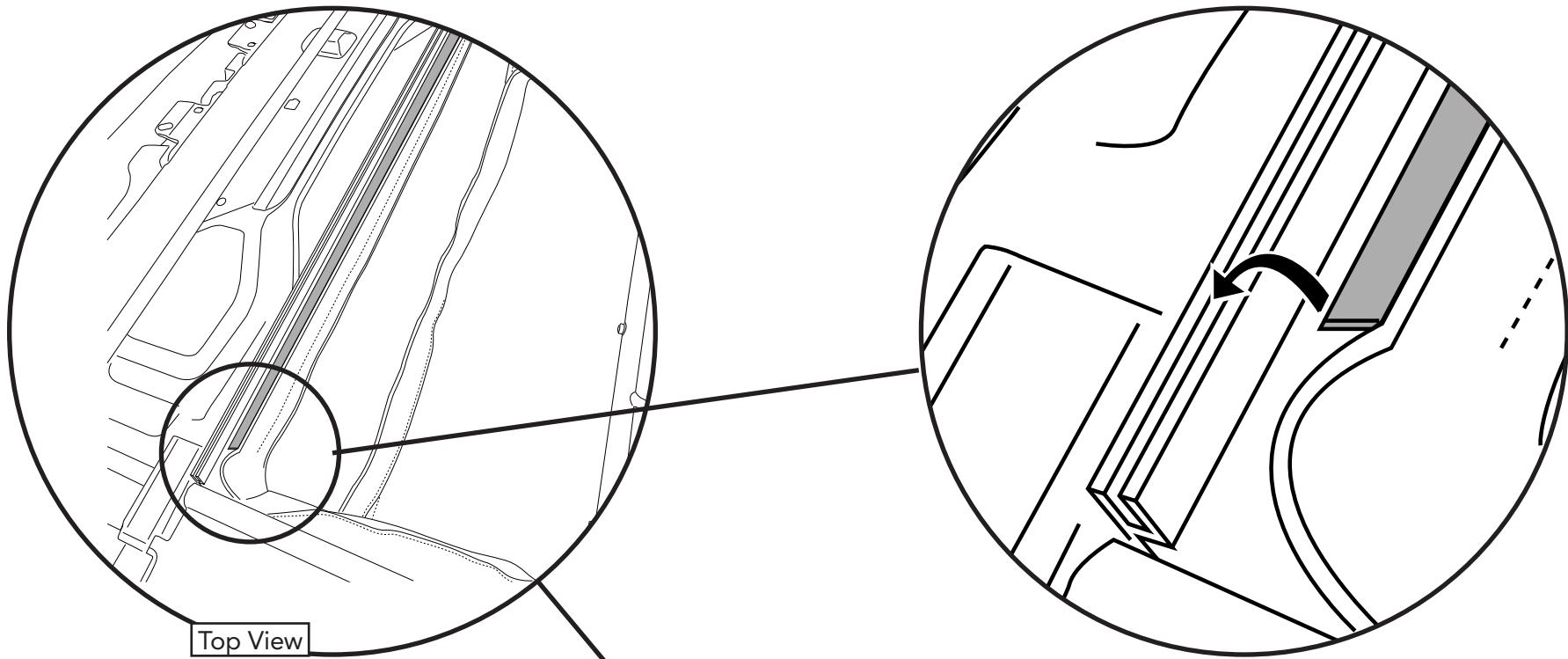

Tuck the plastic retainer located across the top of the Windjammer and Place it into the Aluminium Retainer that was installed in Section 5.



Parts

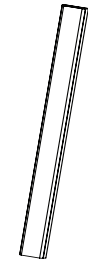

Bow C Pillar
Part #629.13
Qty. 2

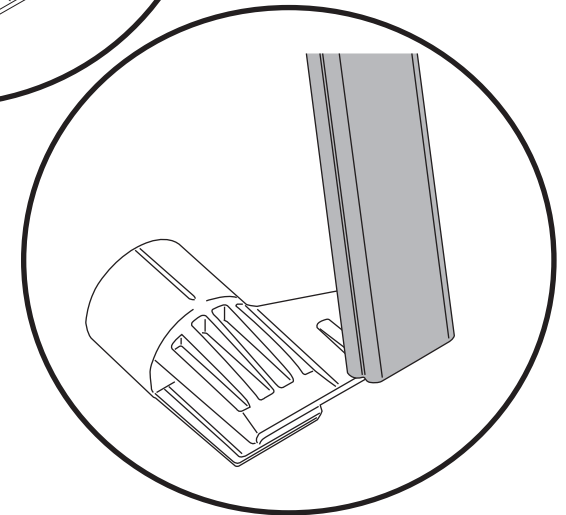
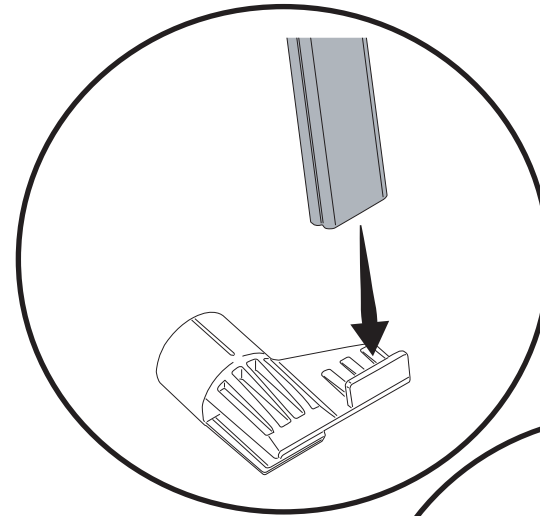
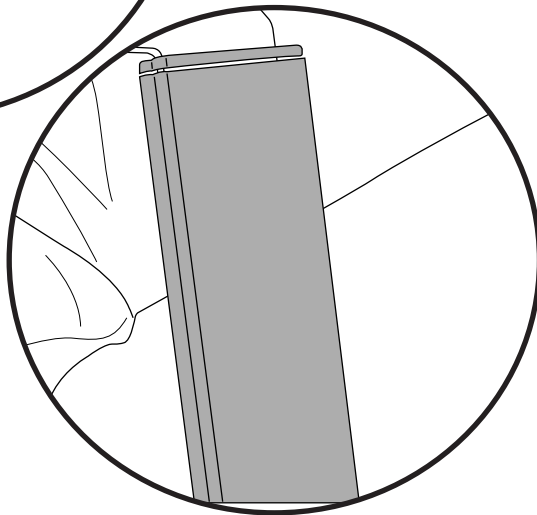
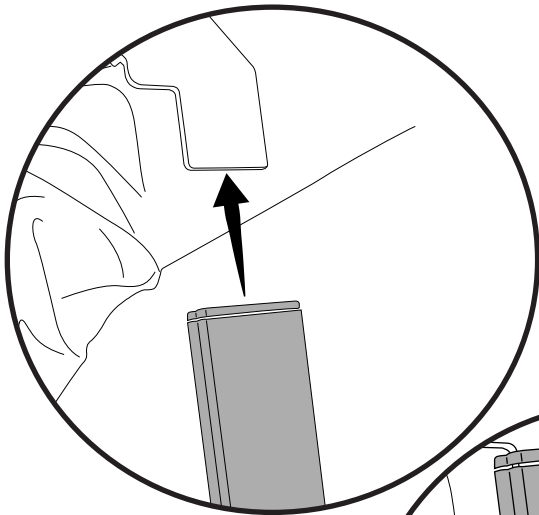

Insert the top of the C Pillar Bow (Part # 629.13) onto the Bow Support Bracket and push it all of the way up.

Align the C Pillar Bow with the tab on the End Cap then pull the C Pillar bow down onto the tab.

Repeat the steps on the left side of the vehicle.



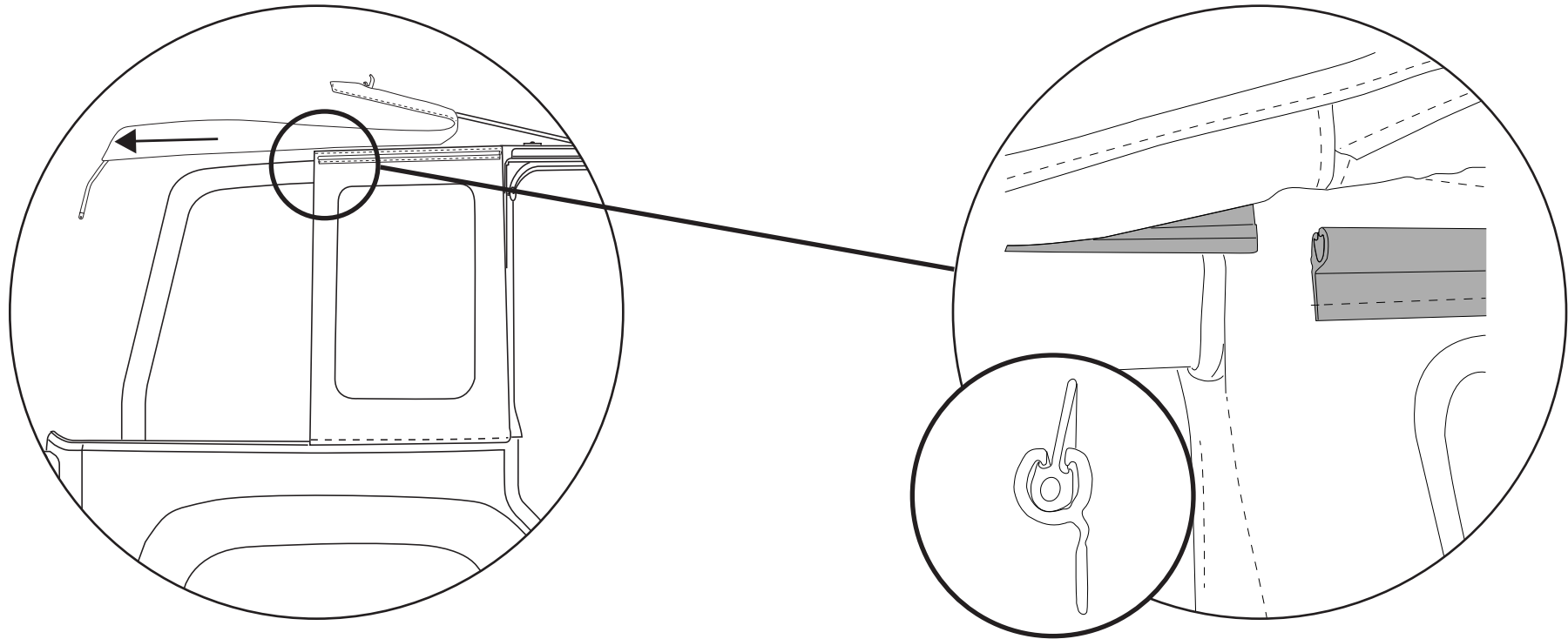

MAke sure the header is folded back then slide the Top Assembly back.

Starting at the front of the exrrusion on the top and the rear of the extrusion on the Side Panel, Slide the "P" Extrusion towards the front of the vehicle along the "C" Extrusion until both ends meet at the front of the Side Panel Extrusion.

Repeat on the left side window.

Fold the front section of the top back.

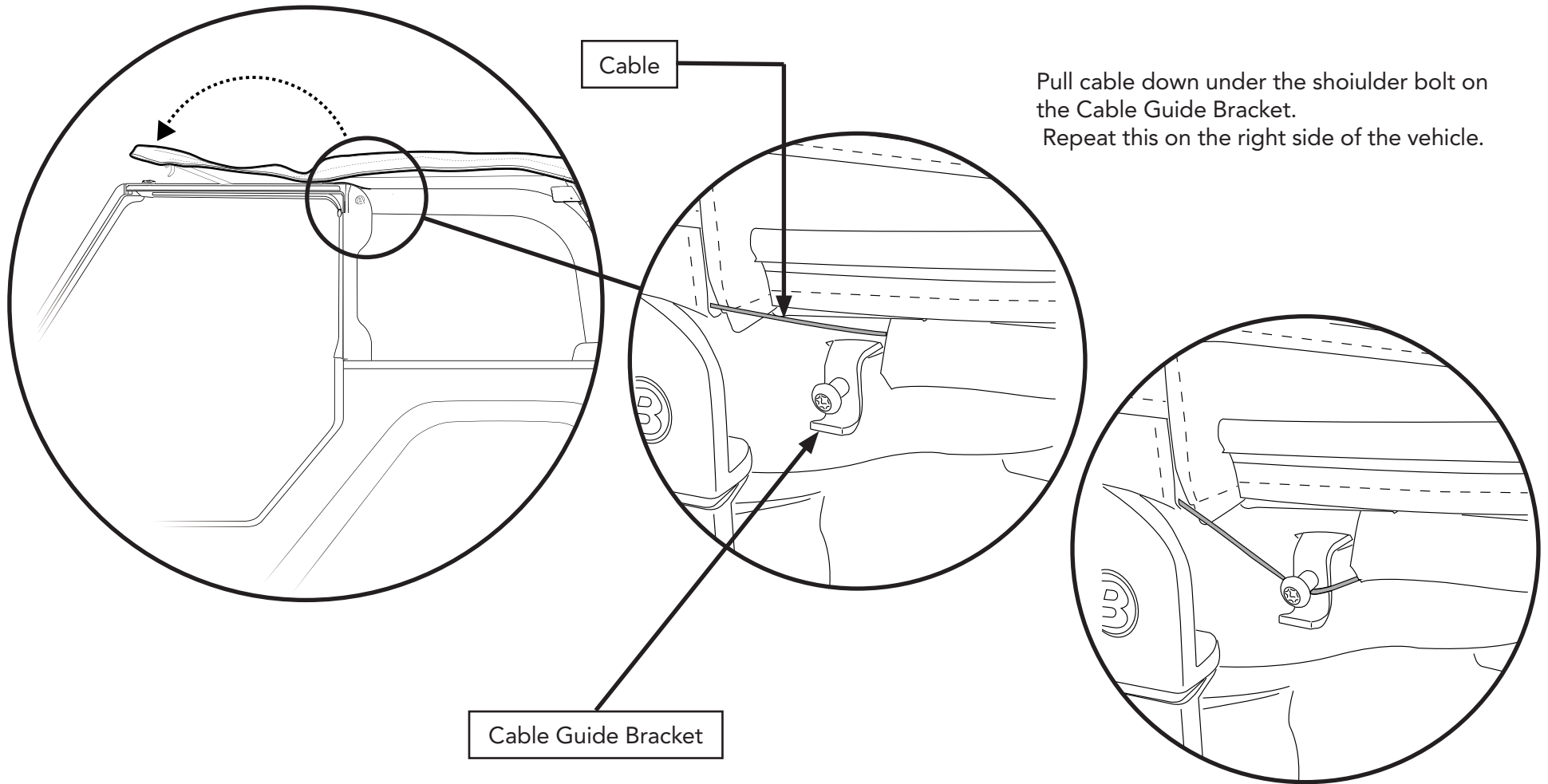

Pull cable down under the shoulder bolt on the Cable Guide Bracket.
Repeat this on the right side of the vehicle.

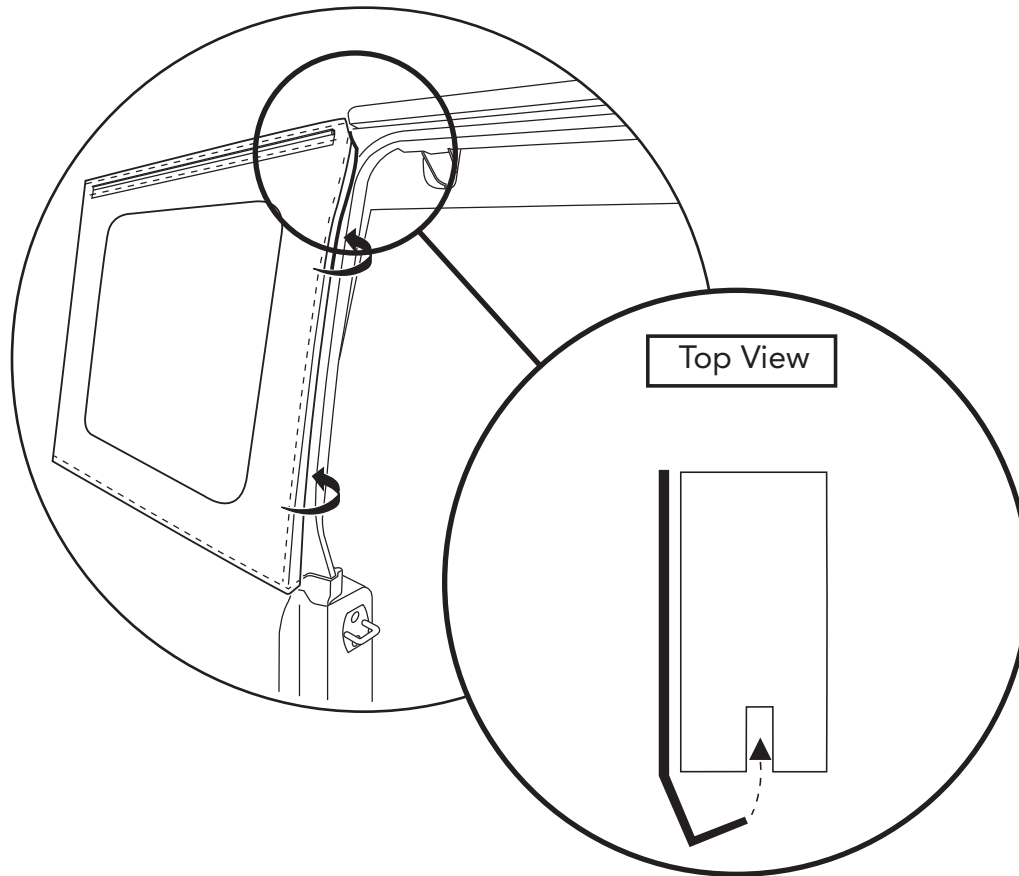

Locate the the sewn-in plastic strip along the front edge of the left side window. Tuck this plastic strip into the vertical channel along the outside face of the Right Rear Door Rail.

Attach the Tailgate Bar to the sewn-in P-Extrusion rail on the underside of the rear of the Duster. Slide the Tailgate Bar all the way across the "P" extrusion. (As it was on the rear window of the Trektop)

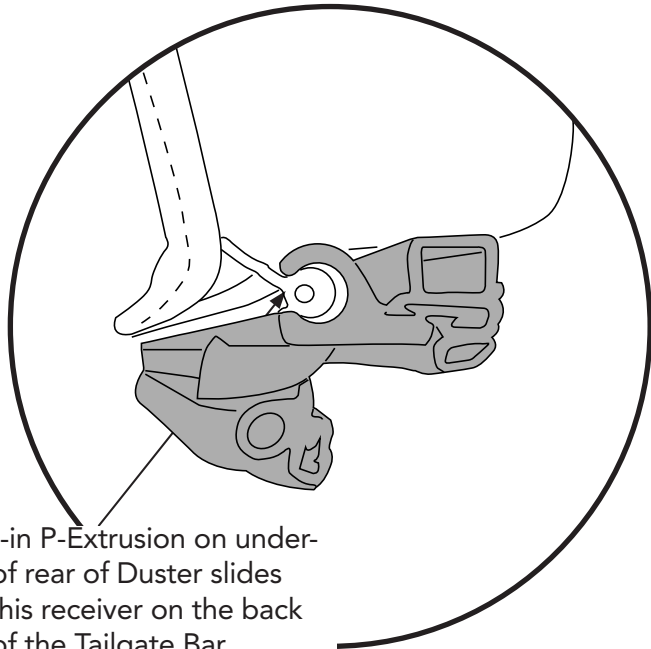

Sewn-in P-Extrusion on underside of rear of Duster slides into this receiver on the back side of the Tailgate Bar.

Secure the Tailgate Bar with attached Duster to the Tailgate Bar Retainers. Press the Tailgate Bar into the receiver on each Tailgate Bar Retainer.

NOTE: The bulb seal on the Tailgate bar must hang below the bar and face rearward for the tailgate to touch it.

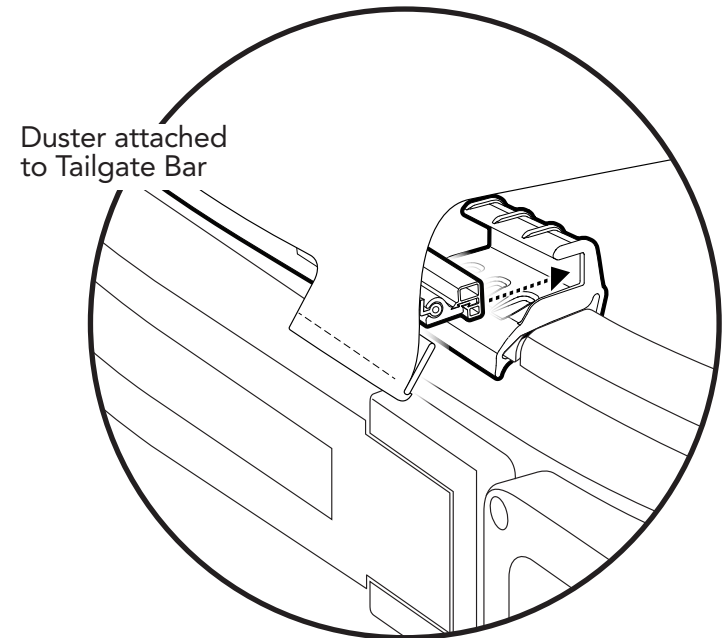

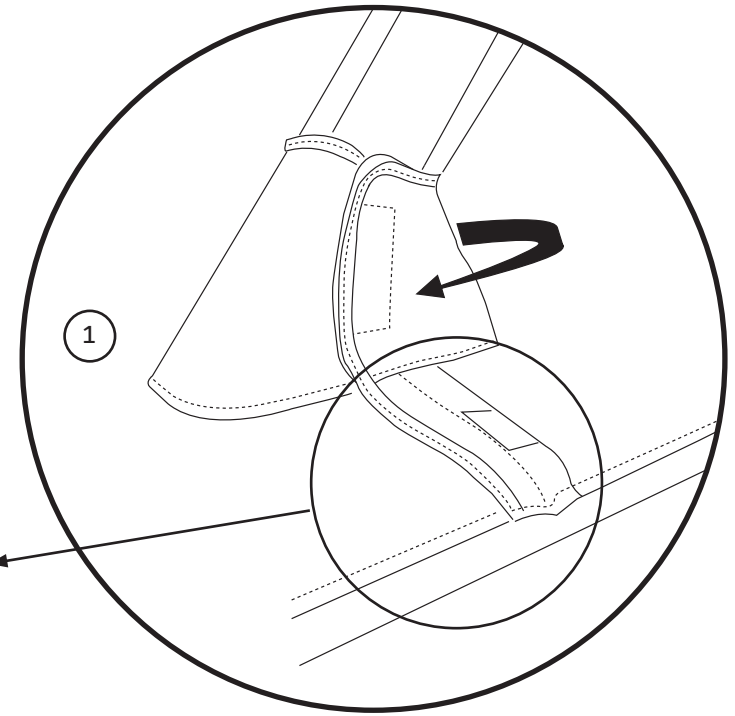
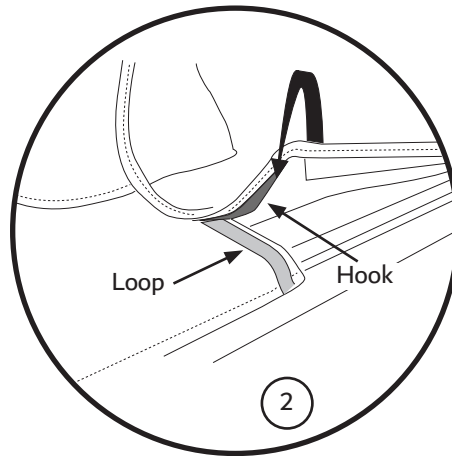
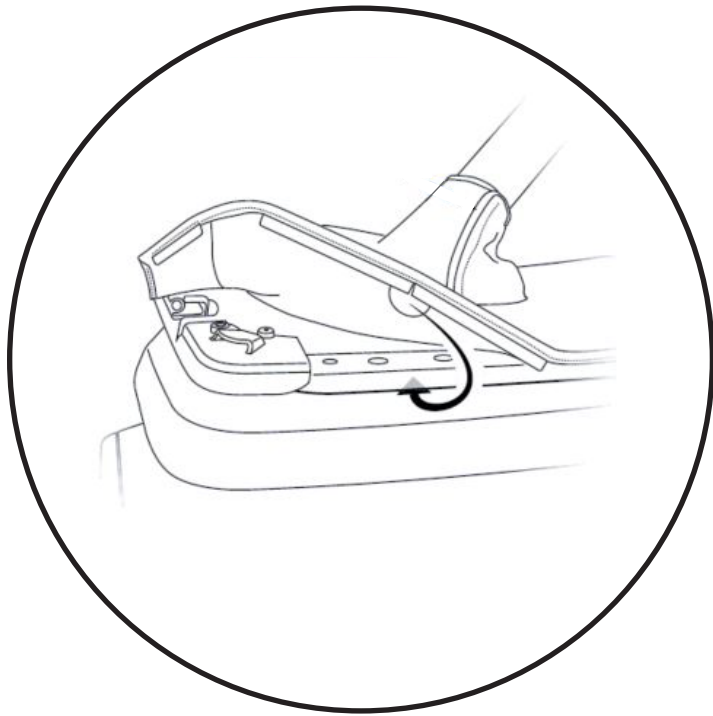

Tuck the plastic tabs along the left and right edges of the Duster underneath the Jeep belt rail, working from back to front. Make sure to tuck the straight tabs as well as the semi-circular tabs under the belt rail.

Tuck the plastic tabs at the rear corners under the belt rail. Next, Tuck all side plastic tabs under the belt rail, from back to front.

- ① Wrap the hook-&-loop sleeves around the sport bar downtubes, and attach hook-&-loop strips together snugly.
- ② Press the Hook and Loop together along the side of the Duster cover

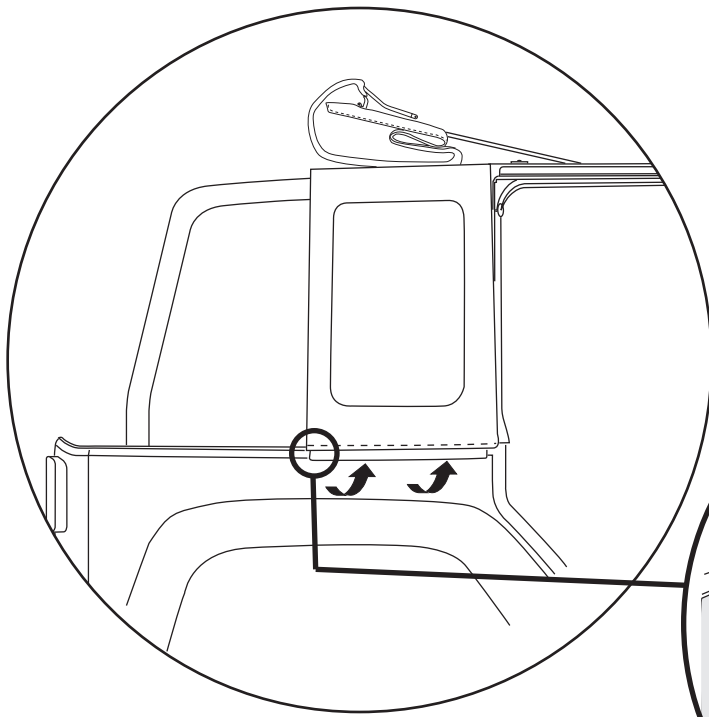

Tuck the plastic strip along the bottom edge of the left rear window under the Jeep belt rail, by rolling it up underneath the belt rail, beginning at the rear, and working your way forward. Make sure you tuck the tab on the front edge of the Duster under the bottom edge of the Side Panel.

Repeat on the left side window.

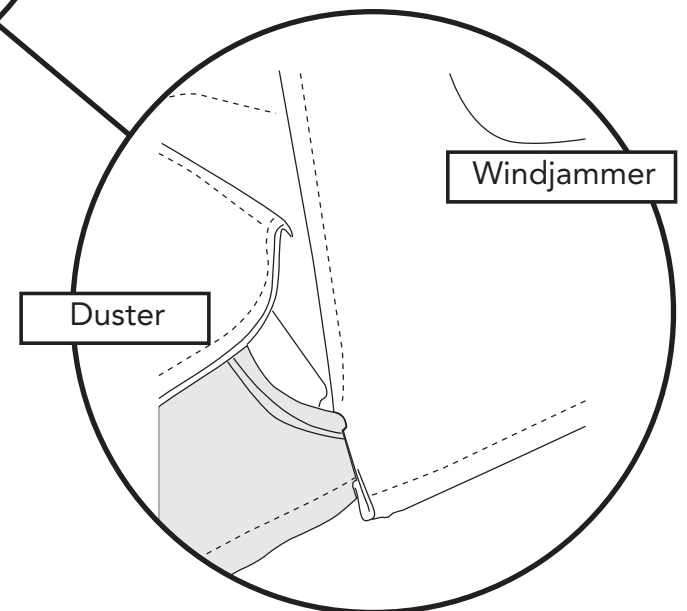
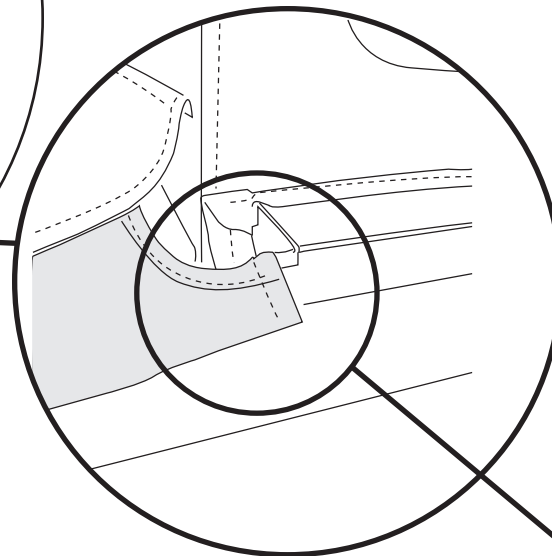

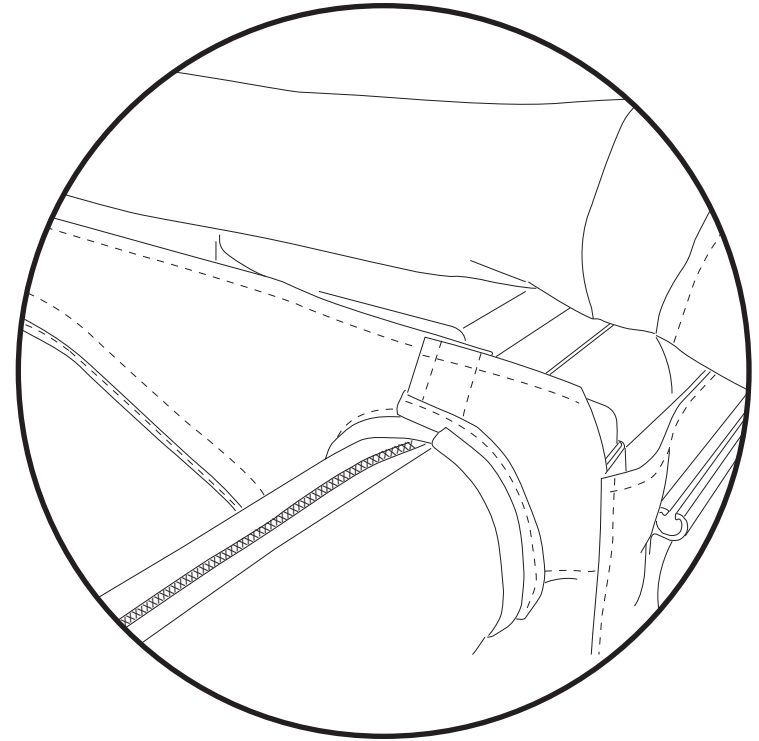
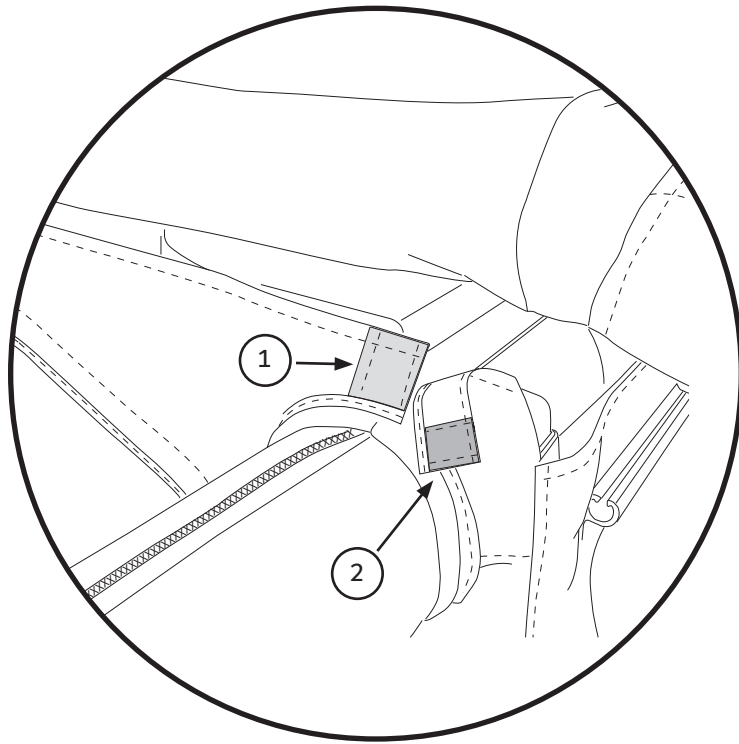

- 1 Pull the tab with the loop over the top of the sport bar.
- 2 Pull the tab with the hook over the top of the tab with the loop and press together.

Repeat on the left side of vehicle.



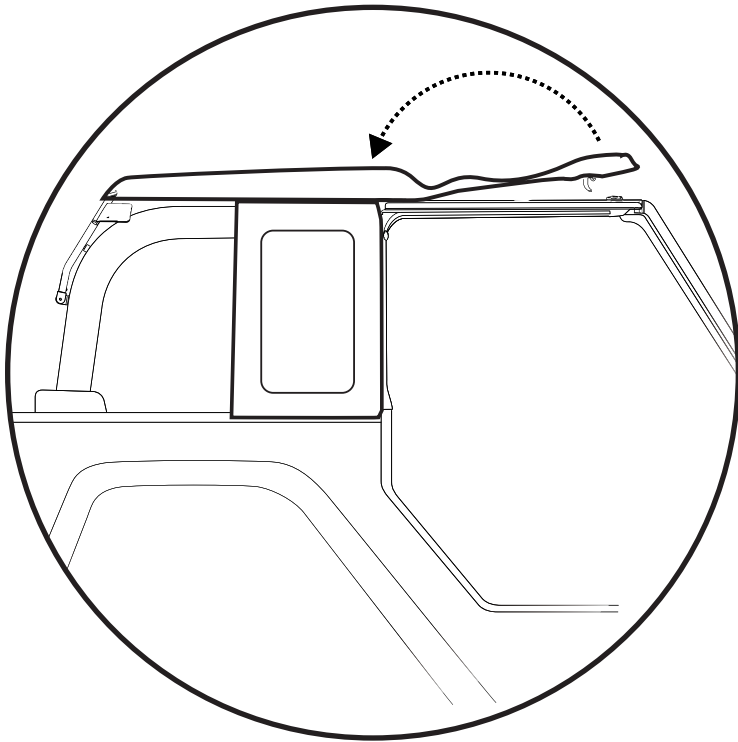

Make sure the front section of the top is folded back.

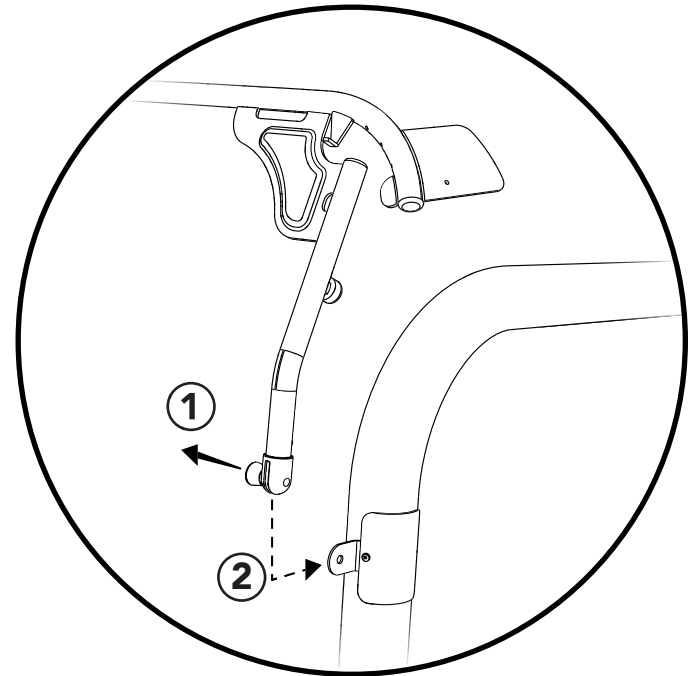

Attach the Rear Bow Assembly to the Pin Point Bracket on the rear downtube of the sport bar by pulling out on the spring catch release knob, and sliding the catch over the protruding tab of the Pin Point bracket as shown in the diagram above.

Repeat for the left side.



Warranty Information Trektop Halftop Kit

Vehicle Application:
Jeep® Wrangler JK 2007-2018
Part Number 80102

WHAT BESTOP WARRANTS

Subject to the terms and conditions of sale, including any terms and conditions set forth by Bestop, Inc. ("Bestop" or "us" or "we") in our then-current terms of sale on our website (collectively, the "Terms"), Bestop represents and warrants that: the covered products listed in the "Covered Products and Warranty Periods" section (a "Product") will substantially be free from defects in materials and workmanship for the specified warranty periods set forth in that section.

THE WARRANTY IS LIMITED AND CONDITIONAL

This warranty applies to the original purchaser of the Product only. The warranty is valid only as long as the original retail purchaser owns the vehicle upon which the Product is installed. The warranty expires should the Product be removed from the original vehicle or if the original vehicle is transferred to another owner. This warranty is not transferable or assignable. The warranty does not apply to Product bought from auction-style or price-bid websites.

THE LIMITED WARRANTY AND STATED REMEDIES ARE SOLE AND EXCLUSIVE AND IN LIEU OF ALL OTHER WARRANTIES AND REMEDIES, AND COMPANY EXPRESSLY DISCLAIMS ALL IMPLIED OR STATUTORY OR OTHER WARRANTIES, INCLUDING WITHOUT LIMITATIONS WARRANTIES OF MERCHANTABILITY, NON-INFRINGEMENT OR FITNESS FOR A PARTICULAR PURPOSE. IN NO EVENT WILL COMPANY BE LIABLE FOR ANY SPECIAL, INCIDENTAL, CONSEQUENTIAL, PUNITIVE, INDIRECT OR EXEMPLARY DAMAGES OF ANY KIND, INCLUDING LOST PROFITS OR REVENUE, HOWEVER CAUSED, WHETHER FOR BREACH OR REPUDIATION OF CONTRACT, TORT, BREACH OF WARRANTY, NEGLIGENCE, OR OTHERWISE, WHETHER OR NOT COMPANY WAS ADVISED OF THE POSSIBILITY OF SUCH LOSS OR DAMAGES.

Some states do not allow exclusion or limitation, so this may not apply to you. This warranty gives you specific legal rights, and you may have other rights which vary from state to state.

EXCLUSIONS TO THE WARRANTY

The Limited Warranty excludes, and Bestop is not liable in any way for any warranty claims, damages, or defects related to:

- Misuse, abuse, accidents, vandalism, negligence, fire, or improper installation or modification, or improper or inadequate maintenance;
- Failure to comply with any Product documentation, Bestop instructions, or applicable law or regulations; use in extreme conditions
- Force Majeure including but not limited to, earthquake, hurricane, tornado, flooding, or other disasters natural or man-made, civil unrest, strikes, declared or undeclared war, or lack of performance by, or discontinued product of, supply chain partners whose products, software, operations or management is beyond the control of Bestop;
- Damage resulting in breakage (including without limitation, spontaneous breakage, accidental breakage or breakage by any other means) of a Product or any component part;
- Damage to vinyl windows due to misuse, or cracking due to varying weather conditions.

YOUR SOLE REMEDY

During the applicable warranty period, Bestop shall, at its option, either repair or replace any Product that it confirms, in its discretion, is non-compliant with the warranties herein. Bestop will not pay for labor charges associated with installation or removal of the Product. Should a specific Product be discontinued, Bestop may, at its option, replace the discontinued Product with a current product or like product.

Please retain your proof of purchase. Original proof of purchase for the Product must accompany any warranty claim. If you have a warranty claim, first you must email Bestop Customer Service at csbestop@bestop.com for instructions. All claims must be emailed to csbestop@bestop.com within 30 days of discovery of a defective Product, but in no event later than thirty days after the end of the applicable Warranty Period (the "Warranty Notice Period"). Warranty claims made after the Warranty Notice Period are null and void and Bestop shall have no responsibility with respect to such claims.

THIS SECTION SETS FORTH BESTOP'S SOLE OBLIGATION & YOUR SOLE REMEDY WITH RESPECT TO ANY DEFECTS OR OTHER PRODUCT ISSUE. ANY PRODUCTS REPLACED UNDER TERMS OF THIS WARRANTY WILL BE COVERED UNDER TERMS & BALANCE OF THE DURATION OF THE ORIGINAL LIMITED WARRANTY FOR SUCH PRODUCT.



Warranty Information Trektop Halftop Kit

Vehicle Application:
Jeep® Wrangler JK 2007-2018
Part Number 80102

COVERED PRODUCTS AND WARRANTY PERIODS: The warranty time periods are as follows for Products manufactured by Bestop:

BESTOP® LIMITED LIFETIME WARRANTY

Trektop® Pro Twill Fabric Top Sunrider® for Hardtop Twill Fabric Top
Trektop® NX Glide Twill Fabric Top Replace-a-Top™ Twill Fabric Top
Trektop® NX Twill Fabric Top Supertop® NX Twill Fabric Top
EZFold™ Soft Tonneaus Floor & Cargo Liners
ZipRail™ Soft Tonneaus Pet Barriers
EZRoll™ Soft Tonneaus

BESTOP® 5-YEAR LIMITED WARRANTY

Trektop® NX Glide™ Top (non-Twill) Sunrider® for Hardtop (non-Twill) Replace-a-Top™ Top (non-Twill) Trektop® NX Top (non-Twill)
Sailcloth Replace-a-Top™ Supertop® NX Top (non-Twill)
Tigertop™ and Halftop™ Supertop® Classic Soft Top Sunrider® Complete Soft Top Supertop® for Truck
EZ Fold Hard Tonneau

BESTOP® 3-YEAR/100K MILES LIMITED WARRANTY

Powerboard® & Powerboard® NX

Trekstep®, Side Mount
Trekstep®, Rear Mount

BESTOP® 3-YEAR LIMITED WARRANTY

Pavement Ends Sprint Top

BESTOP® 2-YEAR LIMITED WARRANTY

Trektop® Classic Soft Top
RoughRider™ Soft Storage

BESTOP® 1-YEAR LIMITED WARRANTY

All other Bestop® & Pavement Ends™ products not specified above.

For further information or request for warranty work, please contact:

Bestop Inc. Customer Service
Toll-Free: (800)845-3567
E-mail: csbestop@Bestop.com
Website: www.Bestop.com