



BESTOP

Windjammer Installation Instructions

For: Suzuki Samurai

Part Number: 80061

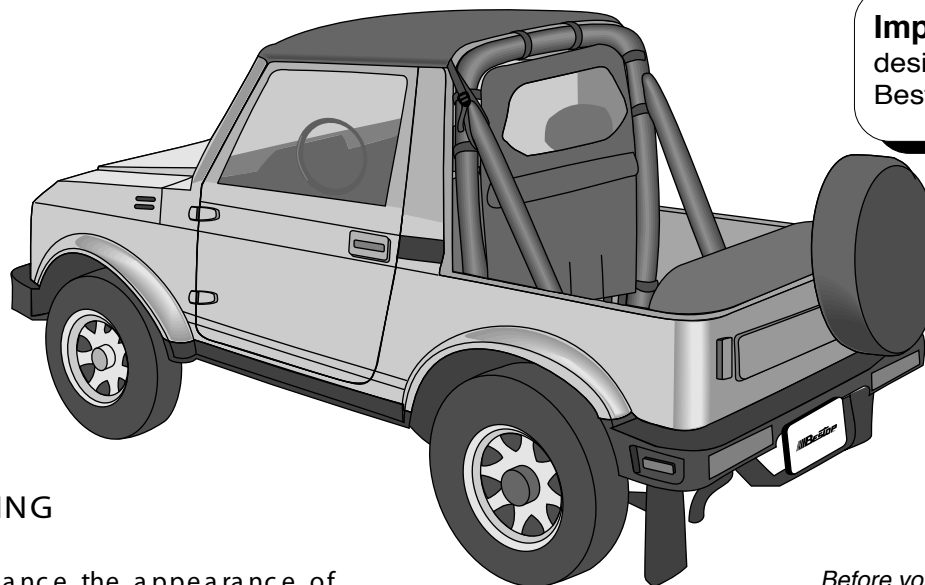

Important Note: Windjammer is custom designed to attach to the leading edge of Bestop's Duster Rear Deck Cover.

WARNING

This product is designed to enhance the appearance of the vehicle. Do not rely in any way on the components of this product to contain occupants or cargo within the vehicle, or to protect against injury or death in the event of an accident. This top will not protect the occupants from falling objects. Never operate vehicle in excess of manufacturer's specifications.

WEAR SEAT BELTS AT ALL TIMES

Read and follow, precisely, all installation instructions provided when installing top. Failure to do so may result in a poor fitting top and could place occupants of the vehicle in a potentially dangerous situation.

Installation Tips

Before you begin installing this Windjammer assembly, read all instructions thoroughly. Below are a few tips to make this installation easier.

For a smooth fit:

For ease in installation, the Windjammer should be installed at temperatures above 72° F. Below this temperature, the fabric may contract an inch or more, making it difficult to fit to the vehicle.

It is normal for the fabric to contract and wrinkle when stored in the shipping carton. Within a few days after the installation, the fabric will relax and the wrinkles will disappear.

Parts List and Hardware Identification

Windjammer Fabric Qty - 1

Tools Needed

1/8" Drill Bit and Drill Motor
Phillips Head Screwdriver
Center Punch
Pencil

Footman Loop, Qty - 4,
Part Number 272.29

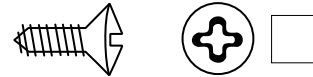

#10 x 1/2" Oval Head Phillips Screw,
Qty - 8, Part Number 155.49

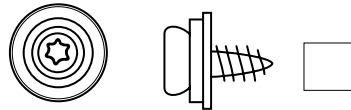

#20 Torx Snap Head Screw, Qty - 3,
Part Number 200.49

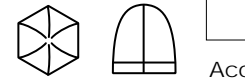

Acorn Locknut, Qty - 3,
Part Number 293.94

Windjammer Installation

Step One

Fold the front seats forward. Orient the Windjammer with the window toward the top and with the vinyl side out, toward the rear of the vehicle. Start with the top straps and wrap the end of each strap around the sport bar and thread it through each buckle. Loosely tighten each strap around the sport bar to hold the Windjammer in position. The bottom strap on each side of the Windjammer will wrap around the sport bar below the sport bar mounting bracket.

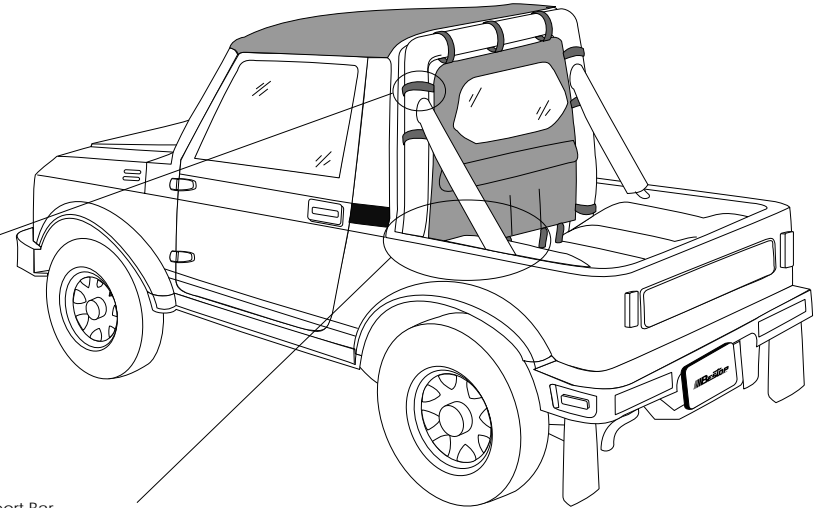
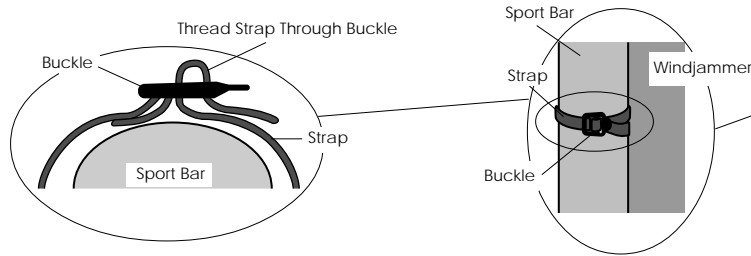

Step Two

Locate the four Footman Loops in the parts kit. Pull the straps sewn to the bottom of the windjammer straight down to position the Footman Loops along the front of the edge of the riser behind the seats. The two outside loops will be placed as far to the outside as the wheel wells will allow and the two center loops will be placed 8 1/4" toward the center of the vehicle from the outside loops. This will also place the two center loops approximately 8 1/4" from each other. Use the Footman Loops as guides to mark, center punch and drill eight 1/8" holes. Install the Footman Loops with eight #10 x 1/2" Oval Head Screws.

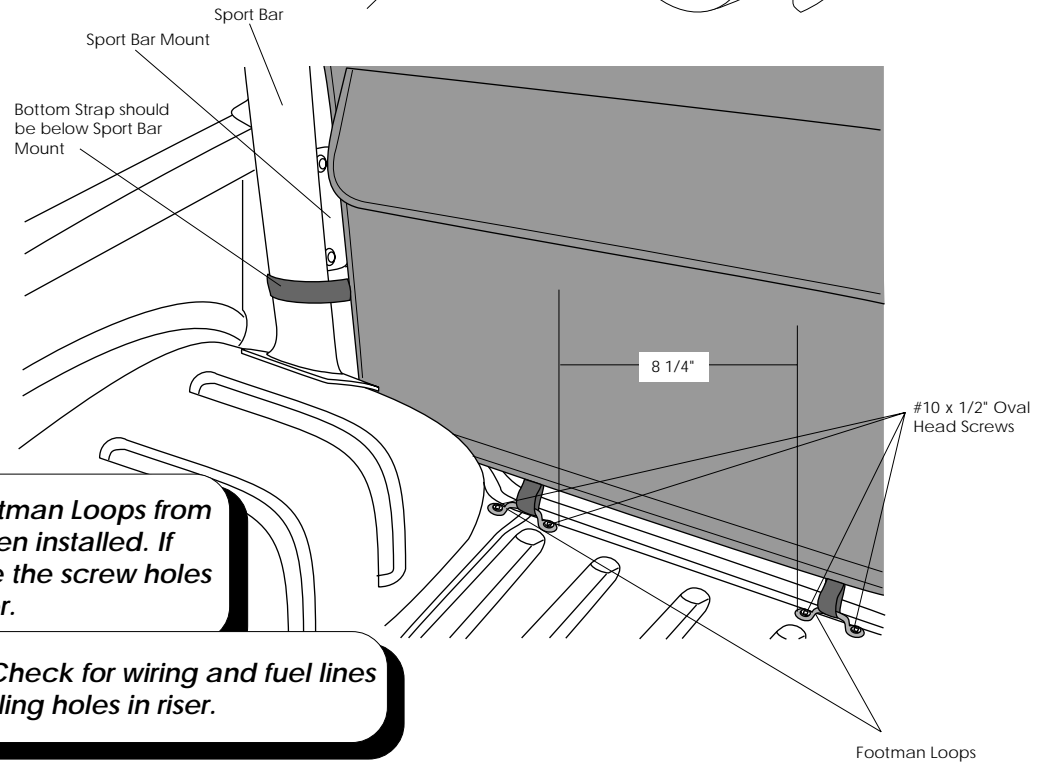

Warning: Do not remove the Footman Loops from your vehicle once they have been installed. If removal is necessary, make sure the screw holes have been covered with a sealer.

Warning: Check for wiring and fuel lines before drilling holes in riser.

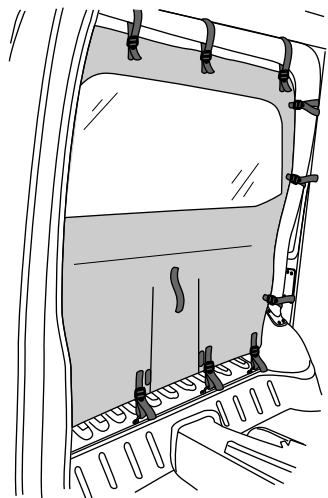

Step Three

Thread the straps on the bottom of the Windjammer through the Footman Loops and back through the buckles. Then tighten all of the straps.

Step Four

To open the center flap in the Windjammer, roll the flap up, wrap the strap around the flap and snap it to the stud on the vinyl side of the Windjammer, under the rear flap.

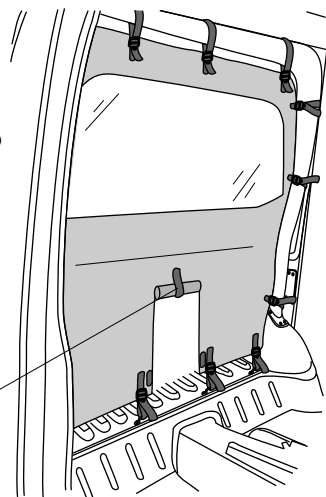

To Open - Roll Flap and Secure with Strap



If You Have a Bestop Duster Rear Deck Cover on Your Vehicle

Step One

Locate the flap sewn to the rear of the Windjammer. Pull the flap out over the top of the front edge of the Duster.

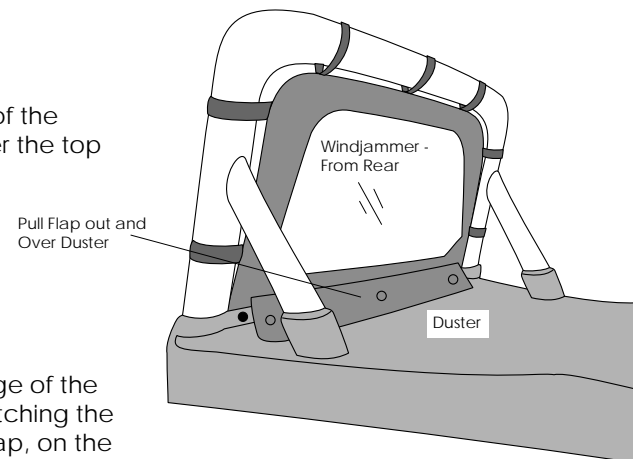

Pull Flap out and Over Duster

Step Two - Optional

Pull up on the front, reinforced edge of the Duster and mark the locations matching the three snaps on the Windjammer flap, on the webbing along the top of the Duster.

Push Snap Head Screw through to form a hole

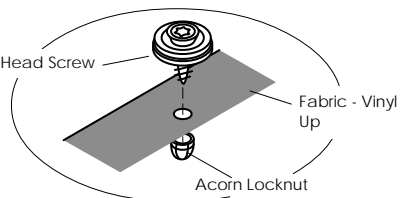
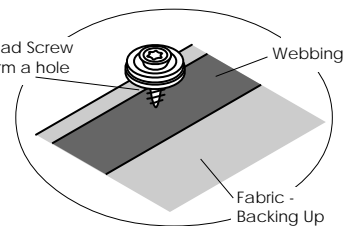

Install Studs on Webbing Reinforced Front Edge

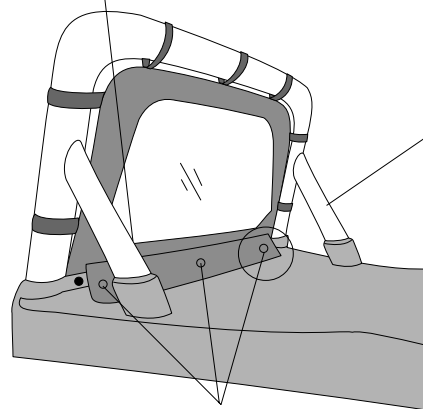

Snaps - on underside of flap

Step Three - Optional

At the marked locations, push the sharp end of a Snap Head Screw through the Duster from the webbing side, to make a hole. Once a hole is formed, pull the screw back out of the hole. Then push the screw through the hole from the vinyl side so that the snap is on top of the vinyl. Thread an Acorn Locknut over the pointed end of the Snap Head Screw. Snap the Windjammer to the Duster Deck Cover.

Care and Maintenance of your Bestop Windjammer

Your Windjammer is made of the finest materials available. To keep it looking new and for the maximum possible wear, it will need periodic cleaning and maintenance.

Washing: The fabric should be washed often using soap, warm water and a soft bristle brush. Rinse with clear water to remove all traces of soap.

Windows: Keep windows clean to avoid scratching. DO NOT use a brush on the windows! Wash with a watersoaked cloth or sponge and a mild dishwashing detergent. NEVER WIPE THE WINDOWS WHEN THEY ARE DRY. Be careful when cleaning snow or frost from the vinyl windows since they are easily scratched and may crack at low temperatures. DO NOT roll the sides or rear window in cold weather. The windows become stiff and will crack.

Water: Seeping through at the seams may be stopped by applying 3-M Scotchgard® on the inside of the seams. Rips in the fabric may be repaired with Bondex® iron on patches. Iron the patches to the inside of the top, carefully following the Bondex® instructions.

Snaps: Keep snaps cleaned and lubricated with silicone to help prevent snaps from sticking to the studs. If a snap does become stuck to a stud, use a screwdriver and GENTLY pry apart to prevent permanent damage to the snap or the top fabric.

LIMITED WARRANTY

We warrant our product to be free from defects in material and workmanship, for the terms specified below, provided there has been normal use and proper maintenance. This warranty applies to the original purchaser only. All remedies under this warranty are limited to the repair or replacement of any item or items found by the factory to be defective within the time period specified.

If you have a warranty claim, first you must call our factory at the number below for instructions. You must retain proof of purchase and submit a copy with any items returned for warranty work. Upon completion of warranty work, if any, we will return the repaired or replaced item or items to you freight prepaid. Damage to our products caused by accidents, fire, vandalism, negligence, misinstallation, misuse, Acts of God, or by defective parts not manufactured by us, is not covered under this warranty.

THE WARRANTY TIME PERIOD IS AS FOLLOWS: ALL "SOFT GOODS" MANUFACTURED BY OUR COMPANY (USING PRIMARILY VINYL, PLASTICS, AND/OR FOAM): ONE YEAR FROM DATE OF PURCHASE.

ANY IMPLIED WARRANTIES OF MERCHANTABILITY AND/OR FITNESS FOR A PARTICULAR PURPOSE CREATED HEREBY ARE LIMITED IN DURATION TO THE SAME DURATION AND SCOPE AS THE EXPRESS WRITTEN WARRANTY. OUR COMPANY SHALL NOT BE LIABLE FOR ANY INCIDENTAL OR CONSEQUENTIAL DAMAGE.

Some states do not allow limitations on how long an implied warranty lasts, or the exclusion or limitation of incidental or consequential damages, so the above limitations or exclusions may not apply to you.

This warranty gives you specific legal rights, and you may also have other rights which vary from state to state.

For further information or request for warranty work, please contact:
Bestop Inc.
Customer Service
(800)346-3910
(303)465-1755

*All or a portion of this product may be made in China.

