

# C6 Z06/ZR1 Corvette Control Arm Bearing Kit Install Instructions

## Tools Required:

- Jack and Jack Stands
- Metric Socket and Wrench set
- Pick
- Flathead Screwdriver
- Balljoint/Tie Rod Separator
- External Snap ring Pliers
- Press
- Mallet
- Torque Wrench
- Dial/Digital Calipers
- Sawzall
- Drill and Drill Bit Set

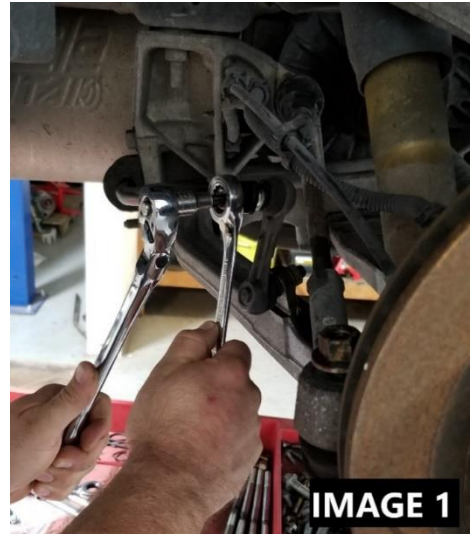

## Rear Disassembly:

1. Lift the rear of the vehicle and safely support on jack stands. Remove both rear wheels.
2. Disconnect rear sway bar endlinks **IMAGE 1**
3. Disconnect wheel speed sensor and parking brake cable. **IMAGE 2**
4. Remove the nut from the toe rod and disconnect the toe rod from the spindle **IMAGE 3**
5. Remove the lower shock mount bolt so the shock can be removed and out of the way **IMAGE 4**

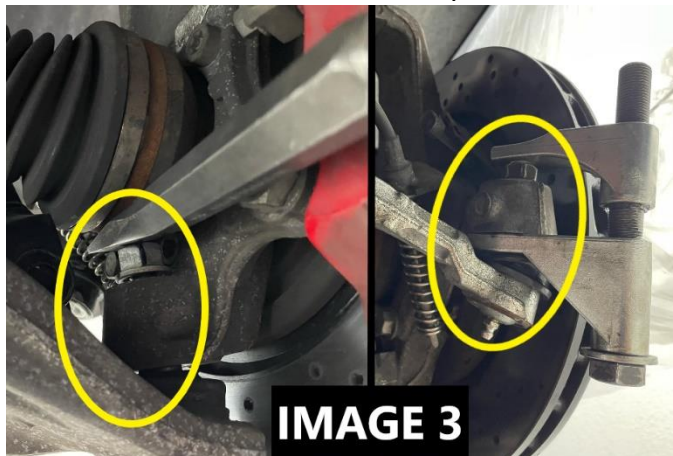

WWW.BMRSUSPENSION.COM

*This product is an aftermarket accessory and not designed by the vehicles manufacturer for use on this vehicle. As such, Buyer assumes all risk of any damage caused to the vehicle or person during installation or use of this product.*

# C6 Z06/ZR1 Corvette Control Arm Bearing Kit Install Instructions

6. Loosen the upper and lower ball joint nuts and knock the spindle loose from the ball joints **IMAGE 5**
7. Support the spindle with a bungee cord or wire tie
8. Mark the bolt position and unbolt the lower control arms from the cradle and unbolt the upper control arms from the frame.



9. Now that all of the control arms are removed, you will need to remove the stock bushings.
10. To begin, start by drilling multiple holes in the bushing to remove the rubber from the bushing.
11. Once enough rubber is removed, fit a jab saw into the bushing and cut through the bushing sleeve (being careful not to damage the control arm).
12. Once you cut through the bushing sleeve, remove the old bushing by tapping it out of the control arm.
13. Repeat this step until all the old bushings are removed.
14. Before installing the new control arm bearings, clean the control arm with brake parts cleaner to remove any remaining debris from the old bushings.
15. Each control arm takes a different bearing. The table below lists where each part number goes as well as the diameter and length of each bearing cup for reference.

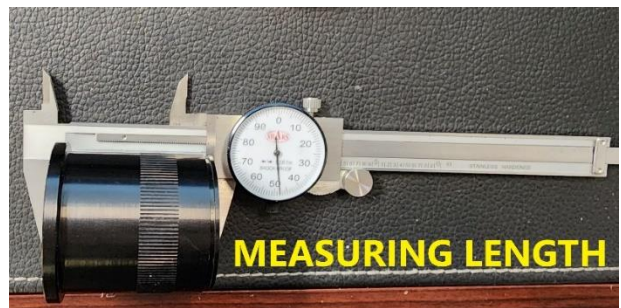
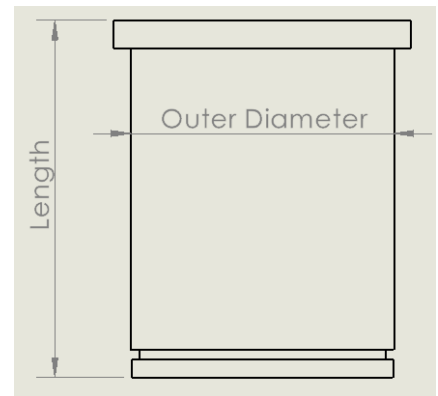
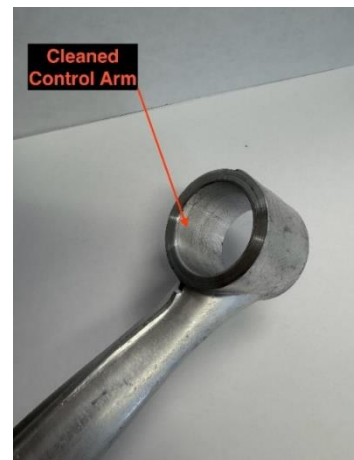

[WWW.BMRSUSPENSION.COM](http://WWW.BMRSUSPENSION.COM)

*This product is an aftermarket accessory and not designed by the vehicles manufacturer for use on this vehicle. As such, Buyer assumes all risk of any damage caused to the vehicle or person during installation or use of this product.*

# C6 Z06/ZR1 Corvette Control Arm Bearing Kit Install Instructions

Qty:	Part Description:	Part #:	OD:	Length:	Snap Ring ID:
2	Lower Control Arm Front Bearing Cup	BMR2786	1.768"	2.270"	1-3/4"
2	Lower Control Arm Rear Bearing Cup	BMR2787	1.887"	2.166"	1-7/8"
2	Upper Control Arm Front Bearing Cup	BMR2803	1.573"	1.663"	1-9/16"
2	Upper Control Arm Rear Bearing Cup	BMR2804	1.731"	1.663"	1-11/16"
4	Upper Control Arm Cross-Shaft	BMR2755	0.740"	4.5"	5/8"
4	Lower Control Arm Front Bearing Spacer	BMR2773	1.240"	1.330"	-
4	Lower Control Arm Rear Bearing Spacer	BMR2779	1.240"	1.215"	-

16. To install the bearings, you **will need a hydraulic press** to press in the new bearing cups.

17. According to the figure, press the bearing cups from the outside of the control arm inward.



[WWW.BMRSUSPENSION.COM](http://WWW.BMRSUSPENSION.COM)

*This product is an aftermarket accessory and not designed by the vehicles manufacturer for use on this vehicle. As such, Buyer assumes all risk of any damage caused to the vehicle or person during installation or use of this product.*

# C6 Z06/ZR1 Corvette Control Arm Bearing Kit Install Instructions

**NOTE:** When installing the cross-shaft, it is recommended to use a green retaining compound installed on the upper control arm bearings before sliding the cross-shaft in.

18. To assemble the upper control arms, slide the cross-shaft into the control arm from the outside inward, according to the figure, and secure it using the supplied cross-shaft external snap ring



19. To assemble the lower control arms, insert the (4) bearing spacers into each lower control arm as shown



20. Install the control arms back into the car and assemble all other components taken off during installation.

**NOTE:** These fasteners are listed as T.A.Y (Torque-Angle-Yield Fasteners), also known as single-use or Torque-to-Yield fasteners.

*Although GM recommends that you replace these fasteners, we have not replaced ours at any point during our design and testing process. Re-use these fasteners at your own risk.*

Torque Specs:

Lower Control Arm Cam Nuts - **125 ft lbs**

Upper Control Arm Mounting Bolts - **48 ft lbs**

Upper Ball joint - **22 ft lbs + 195°**

Lower Ball joint - **22 ft lbs + 180°**

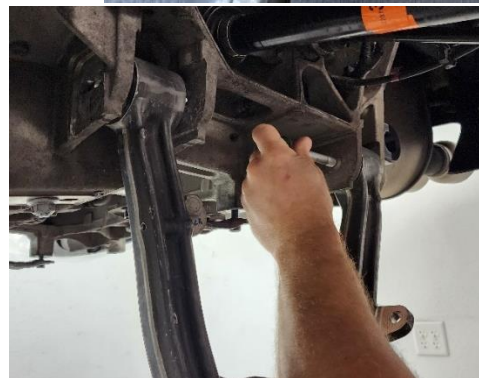

[WWW.BMRSUSPENSION.COM](http://WWW.BMRSUSPENSION.COM)

*This product is an aftermarket accessory and not designed by the vehicles manufacturer for use on this vehicle. As such, Buyer assumes all risk of any damage caused to the vehicle or person during installation or use of this product.*