

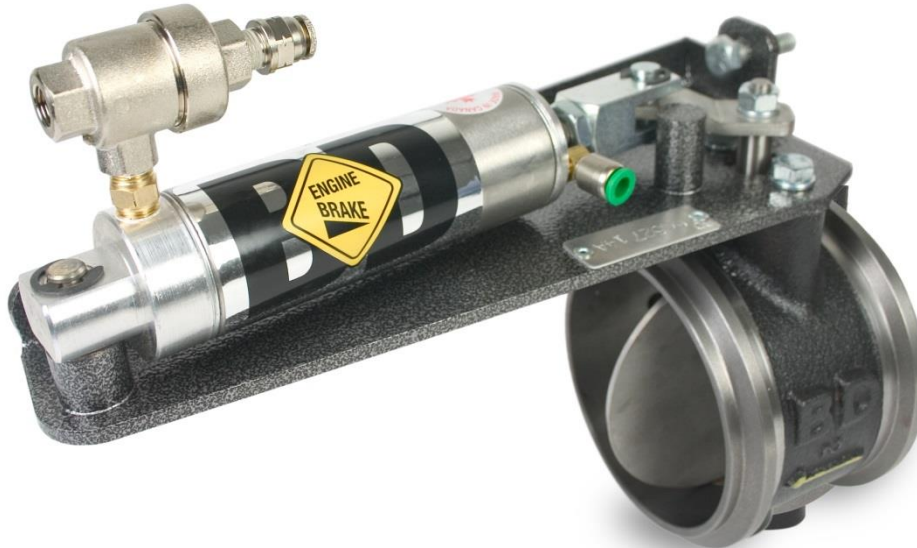

**DOWNLOAD THE LATEST
INSTALL MANUALS AT
www.bddiesel.com**



2011-16 Ford 6.7 Exhaust Brake Remote Mount BD Exhaust Brake

1027150	2011-2016	4" or 5" Exhaust
----------------	------------------	-------------------------

Serial # _____

Date Purchased _____

Purchased from _____

Installed by _____

***** Please read this manual before starting installation. *****

OWNER'S MANUAL - LEAVE IN GLOVE BOX

The brake pressure at idle must be checked and adjusted at time of install, at least two weeks after install, and at regular twice a year intervals.

Table of Contents

Introduction 3

Vehicle Requirements 3

Kit Contents 4

Accessories 5

Tools Required 6

Installation 7

 Brake Valve Installation 7

 Air Compressor Installation 9

 Brake Valve Air Hose Installation 11

 Air Solenoid/Regulator Installation 13

 Regulator Plumbing 16

 Control Module Installation 19

Exhaust Brake Controller Modes 23

 Warmup Mode 23

 Full vs Auto Exhaust Brake Mode 23

Wiring & Plumbing Diagram 24

Exhaust Back Pressure Testing for Air Actuated Brakes 25

 Idle Pressure Test 26

 Off-Idle Pressure Test & Adjustment 26

Maintenance 28

Troubleshooting 28

Introduction

Exhaust brakes help slow down your vehicle by increasing the retarding horsepower available from your engine. Exhaust brakes are highly recommended for use when towing heavy loads and for long hill descents.

This exhaust brake kit is specifically designed for your 2011-2016 Ford Power Stroke truck. It comes with the necessary pipe adapters, brackets and wiring to make installation easier.

The BD Ford 6.7 exhaust brake kit utilizes one of the stock up-fitter (auxiliary) switches on the dashboard for a clean installation. It also features different brake controller modes that can help warm up the engine faster and change the activation method of the brake to suit driver preferences.

This manual is divided into different areas to assist you with the installation and operation of your braking unit. We strongly suggest that you write down the kit and serial numbers of your unit in the spaces provided and retain this manual for future reference.

Vehicle Requirements



This exhaust brake is only intended for vehicles without exhaust after treatment, particulate filter systems or EGR. If the vehicle is still stock we would instead recommend a BD VVB (variable vane turbo exhaust brake) that makes use of the factory VGT turbocharger to help decelerate the vehicle.

This kit is a perfect match for use with aftermarket turbo kits such as the BD Scorpion Turbo Kit (1045800).







Kit Contents

Confirm you have all the parts listed in this kit before proceeding



1127038-A	1030126	1220146
		
Brake Valve Qty: 1	Air Pump Assembly Qty: 1	Regulator/Control Assy. Qty: 1

1304570	1304575	1220112
		
Control Module Qty: 1	Wiring Harness Qty: 1	Air Tubing Kit Qty: 1

MC-3060T54	1040144	1320030	1130227
			
U Bolt Qty: 2	Nyloc Nut 3/8"NC Qty: 4	Air Pump Bracket Qty: 2	Nyloc Nut 5/16"NC Qty: 4

1100402	1100404	1100400	1100500
			
Exhaust Pipe Front Qty: 1	Marmon Clamps Qty: 2	4" Adapter Qty: 1	5" Adapter Qty: 1

1130058	1601522	1100740	90368B
			
Nyloc Nut M6 Qty: 2	Flat Washer M6 Qty: 2	4" Exhaust Clamp Qty: 1	5" Exhaust Clamp Qty: 1

1003449	1300285	1300131
		
Switch Sticker Qty: 1	Posi-lock Qty: 1	Wire Ties Qty: 18

Accessories

Description

Part #

Brake Pressure Testing Gauge



1030050

Cool Down Timer (Turbo Timer)



1081160

Tools Required

- Measuring tape or ruler
- Reciprocating saw or hacksaw
- Wire Crimping Pliers
- Socket Set
- Heat gun or lighter

Optional: Welder

Installation

To prevent damage to electronic components, it is recommended that both battery negative terminals be disconnected while working on the vehicle.

Please read this manual thoroughly before installing this exhaust brake.

Brake Valve Installation



Raise and support the vehicle with a vehicle hoist or with appropriate jack stands.

Ensure vehicle is safely supported before proceeding to reduce possibility of damage or injury.

Loosely assemble the exhaust brake casting to the supplied front pipe and rear adapter of choice (depending if 4 or 5 inch exhaust) using the two Marmon clamps.

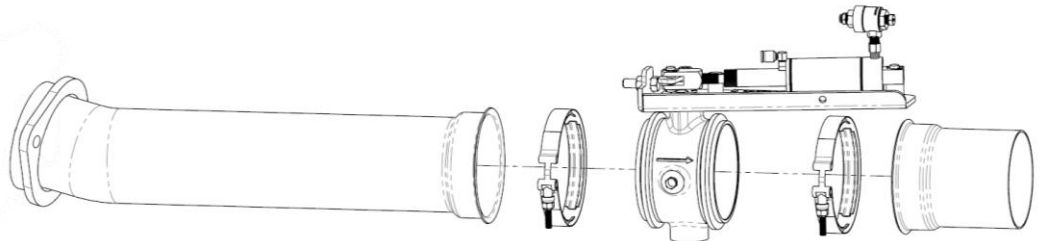

Position the new front exhaust pipe where it will meet up to the downpipe and mark the approximate location of pipe to cut so that the brake outlet adapter will overlap sufficiently.

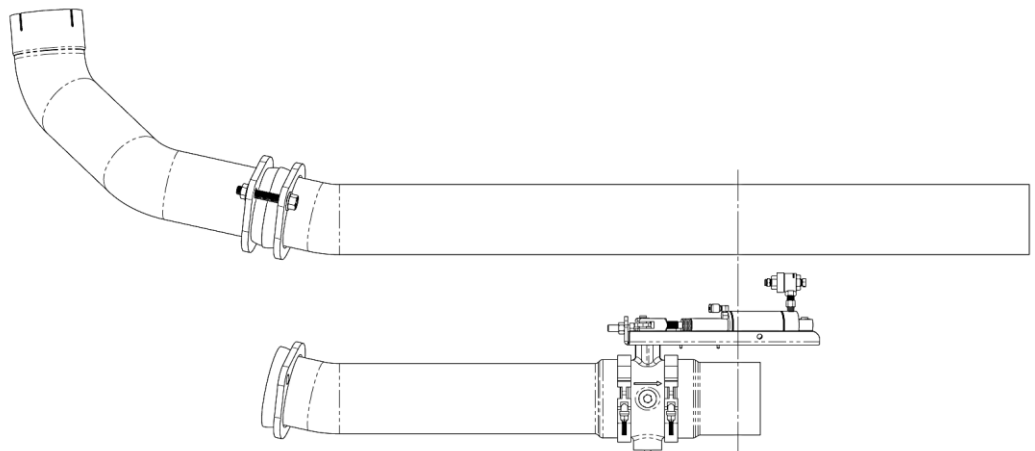

Disconnect the “ball flange” at the bottom of the downpipe and cut out the front exhaust pipe portion using a reciprocating saw or other appropriate tool.

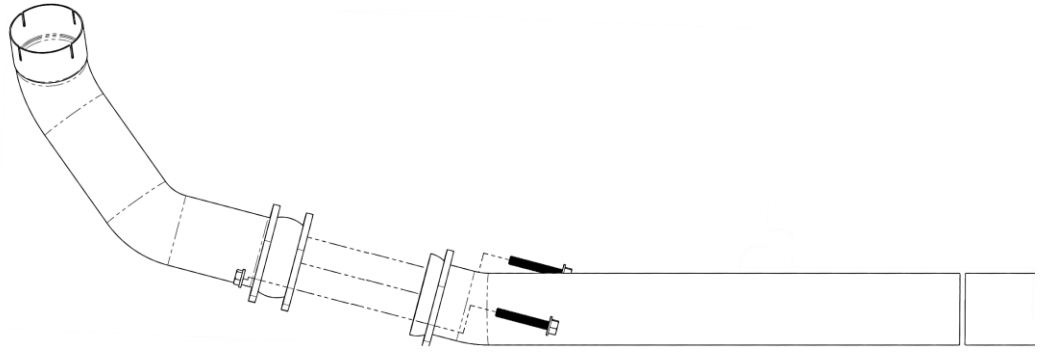

IMPORTANT If using a two piece aftermarket downpipe, it is recommended that the lap seal be welded fully to prevent exhaust leaks when the brake is on. Leaking exhaust will reduce the brake effectiveness, may emit soot in the engine bay and exhaust gas could be drawn into the vehicle cabin.

Loosely install the front exhaust pipe to the downpipe. Slide the rear pipe over the existing exhaust pipe and loosely clamp the brake valve in the middle.

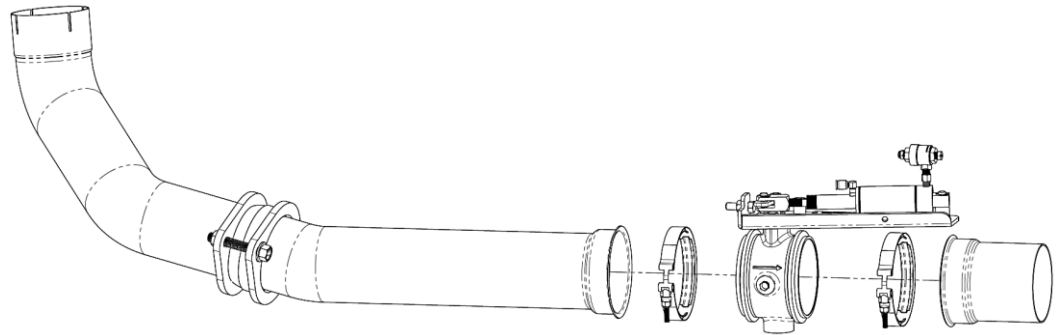

Rotate the exhaust pipes to the correct orientation and rotate the brake valve so that there is sufficient clearance from the vehicle frame, body, transmission etc. Once everything is in place, tighten the front exhaust pipe to downpipe connection and the brake valve clamps. Ensure alignment is still satisfactory afterwards.

Finally install and tighten the rear exhaust lap clamp in place. If desired, this joint may be welded instead.

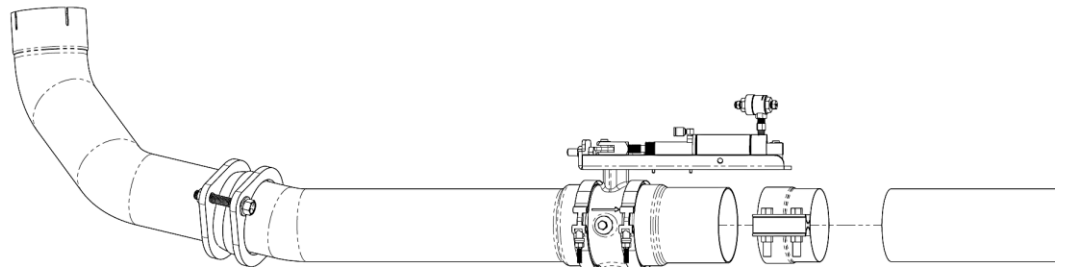

Air Compressor Installation

Install the frame adapter brackets (1320030) to the air pump assembly (1030126) with the supplied 5/16" Nyloc nuts (1130227). Tighten to 10 ft-lb (120in-lb)

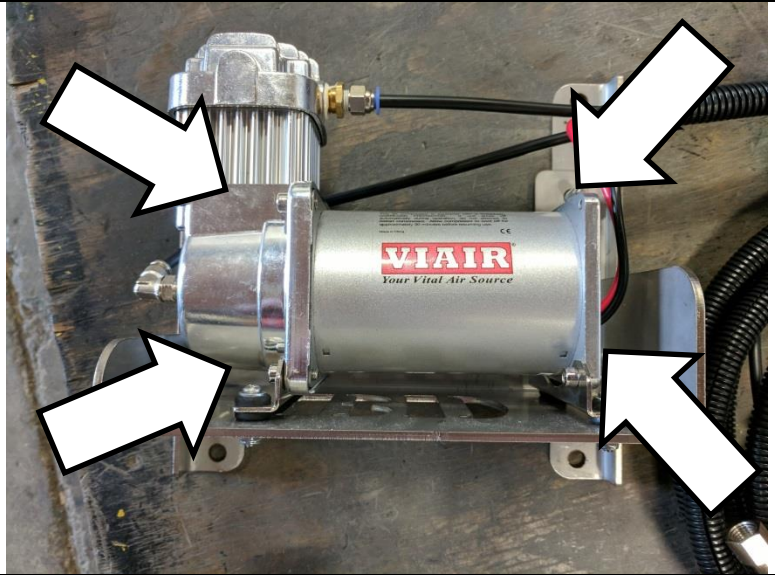

Remove the supplied nuts and washers from the two U bolts (MC-3060T54). Discard the nuts, keep the washers.



Locate the flat section of frame rail on the outboard side below the passenger door; this is the pump mounting location.

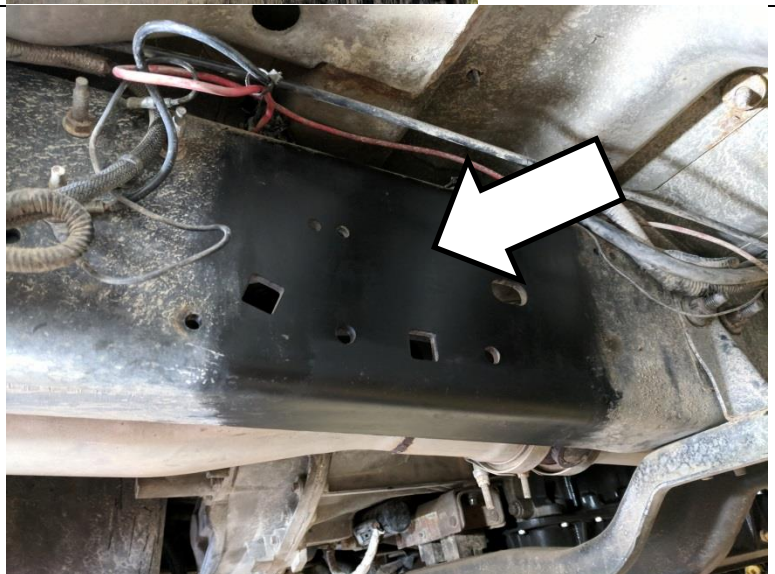

Position the two U bolts (MC-3060T54) on the frame, ensuring they are not pinching any wiring or tubes.



Install compressor assembly onto U bolts and secure with supplied 3/8" Nyloc nuts (1040144) and the washers supplied with the U bolts. Torque to 15 ft-lb or until the bracket begins to slightly distort.

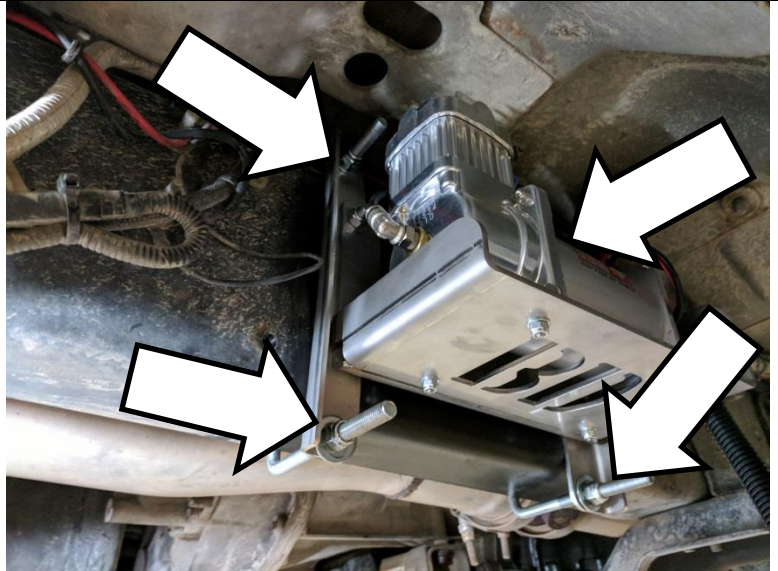

Remove the passenger side front fender liner to make it easier to route the air lines from the compressor to the engine bay. To remove the liner, remove the 8mm and 5.5mm fasteners securing it in place.



Route the airline / wire assembly from the air pump along the outboard side of the frame rail towards the engine bay, following the factory wiring harness.

Do not install on the inboard side to reduce exposure to radiant heat of the exhaust pipe.



Route the lines up the firewall and leave in the engine bay for the next steps.



Brake Valve Air Hose Installation

This kit is supplied with a premade air tubing assembly (1220122). The 1/8" air tube is the pressurized air feed to the brake pneumatic cylinder and the 1/4" air tube is the vent line for the cylinder.



It is easiest to feed these tubes down from the engine bay. The end with the air filter will stay in the engine bay; the end with the bare tubes will connect to the brake valve.

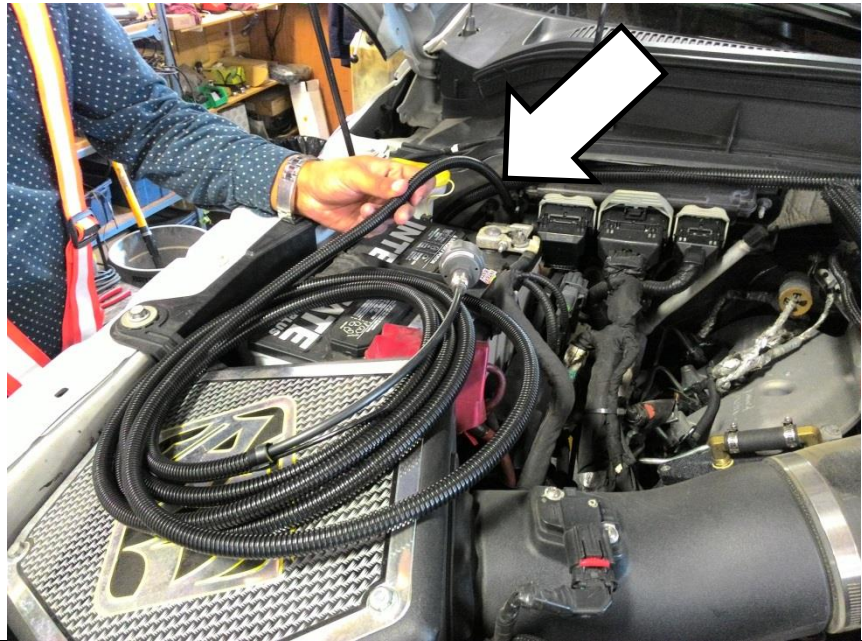

Route it alongside the pump air lines installed earlier and zip tie in place.

Carefully support the line where it crosses the top of the frame rail to the brake valve. Position this to minimize exposure to the exhaust but allows for a small amount of flex to account for exhaust movement.

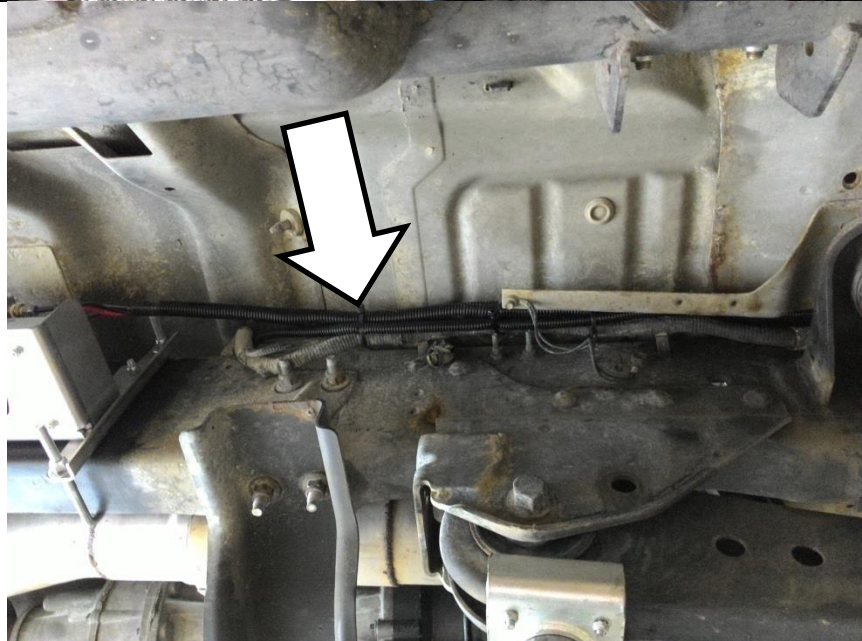

Insert the 1/8" air tube into the quick connect fitting on the quick release valve on the exhaust brake air cylinder.

Insert the 1/4" tube into the vent-side quick connect fitting.

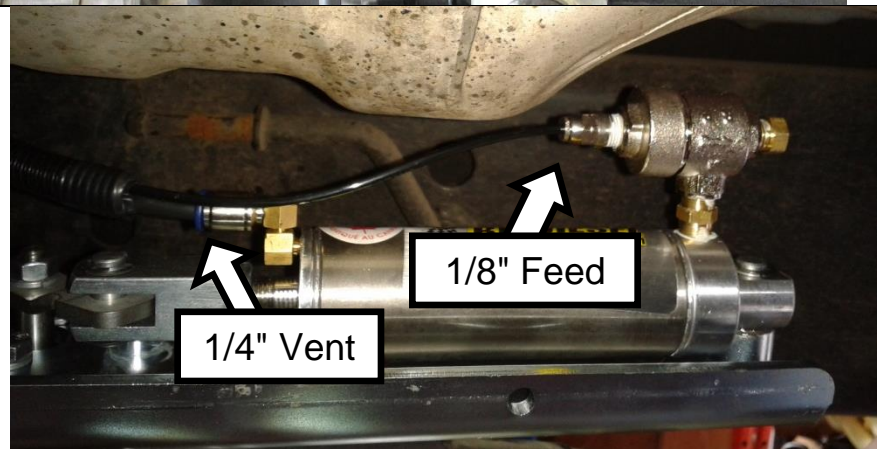

Zip tie the tubing in place with the air pump tubing routed earlier. Ensure where the lines go up the firewall they are kept away from the exhaust pipe.

The fender liner may now be reinstalled.

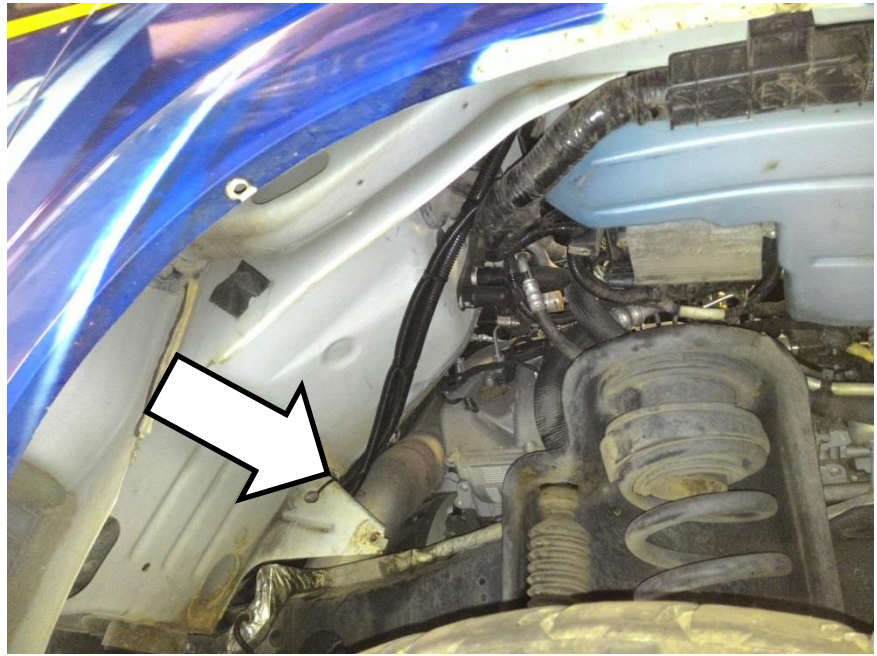

The two sets of air lines and the pump wire will now be left in the engine bay to be hooked up in future steps. Note the lines come up the firewall at the extreme right to avoid the exhaust pipe.



Air Solenoid/Regulator Installation

The air pressure regulator assembly is to be mounted at the top of the firewall on the driver's side using two existing mounting studs.



Remove the ground strap bolt on the top of the firewall.



Position the regulator assembly (1220146) over the two M6 studs and install using the supplied M6 washers and nuts. Torque to 50 in-lbs.

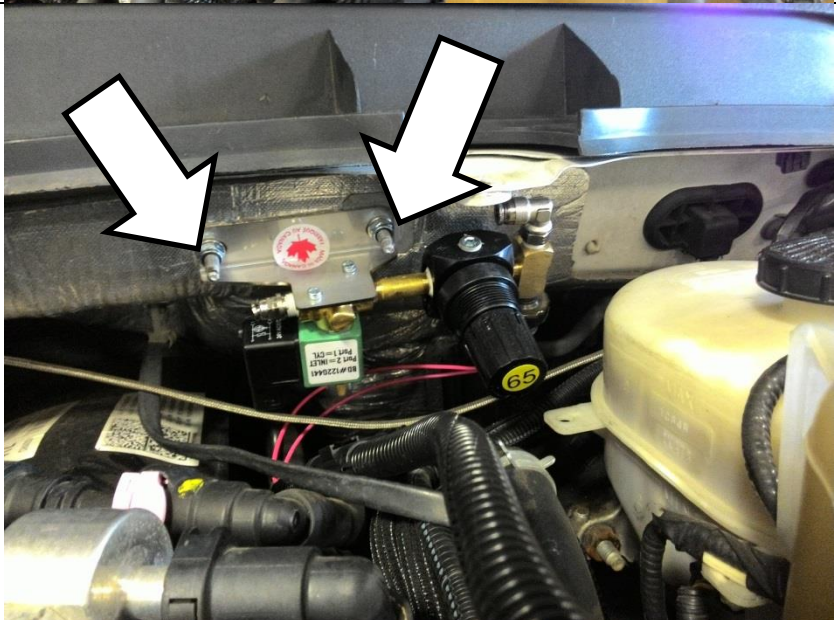

Affix the relay from the wiring harness to the vehicle. This can be installed with a self-tapping screw to the firewall or simply zip tie the relay socket in an accessible place.

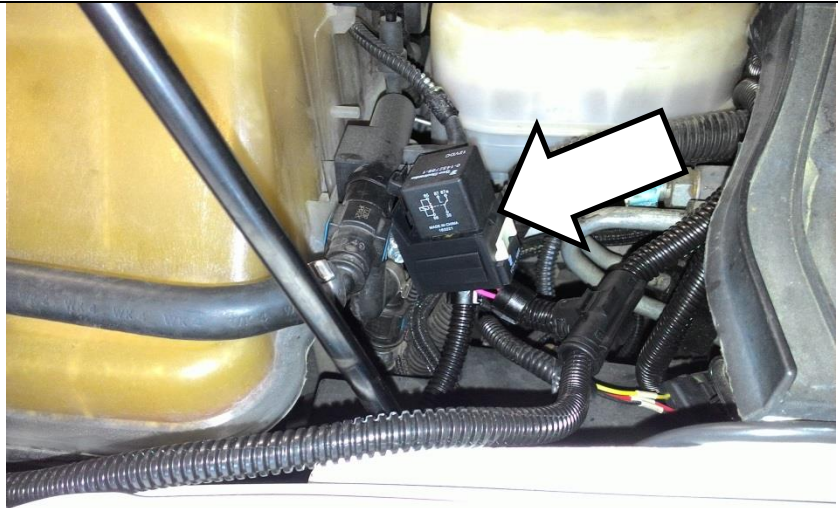

The ground wire (black wire with ring terminal) from the kit is installed with the body ground strap. Reinstall the bolt removed in the preceding steps.

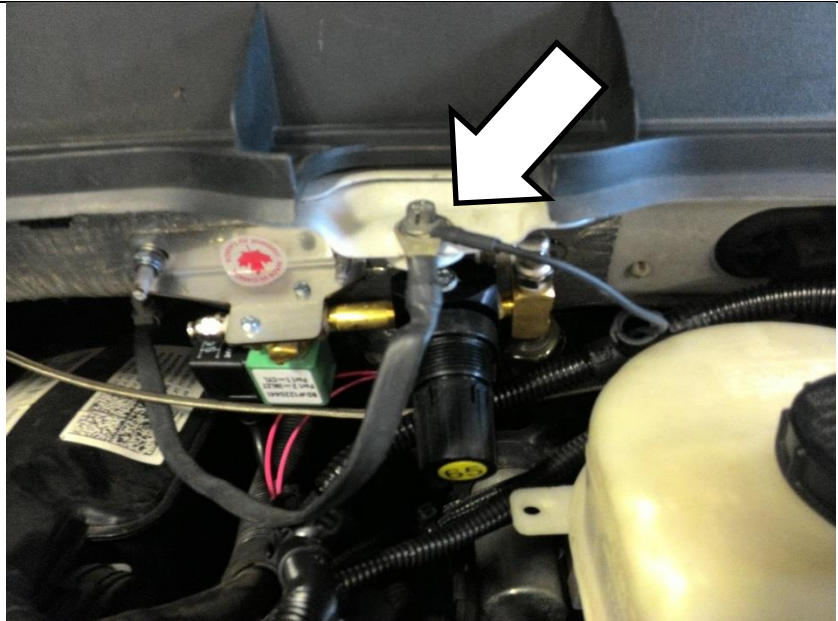

Route the battery power wire (red wire with ring terminal on the end) to the battery positive terminal and install under battery terminal bolt.



Leave the pink wire from this harness for now, it will be attached to the module output in a later step.

Regulator Plumbing

Route the two air tube assemblies (from the pump and brake valve) across the top of the engine bay/lower wiper cowl towards the air solenoid/regulator assembly, secure with zip ties to keep them off of the motor.

You may need to drill a couple of small holes in the plastic cowl to add zip ties here.

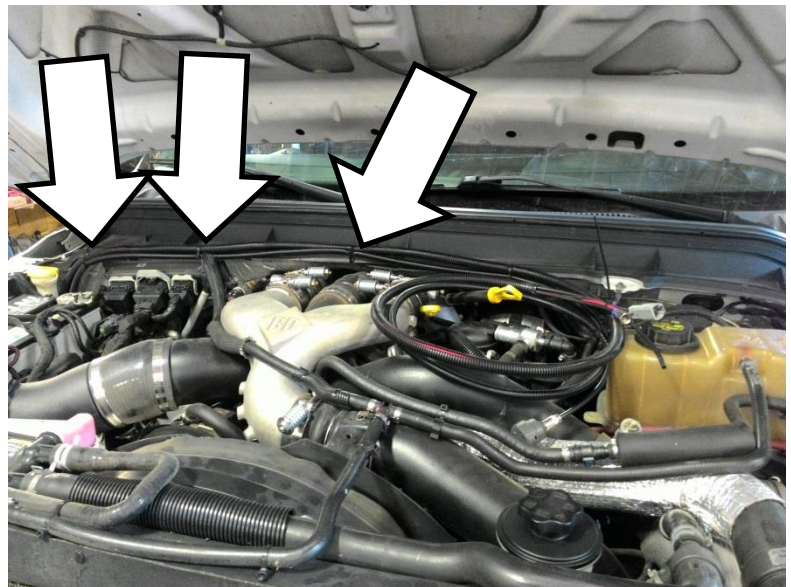

Depending on the routing of the airlines, they may need to be trimmed. The lines are supplied long to account for various line routings. Cut the tubing square and ensure the end is round so it will seal when installed.

Locate the 1/8" tube from in the air tubing assembly that leads to the brake valve. This will be installed in the air output from the air solenoid in the 1/8" fitting.

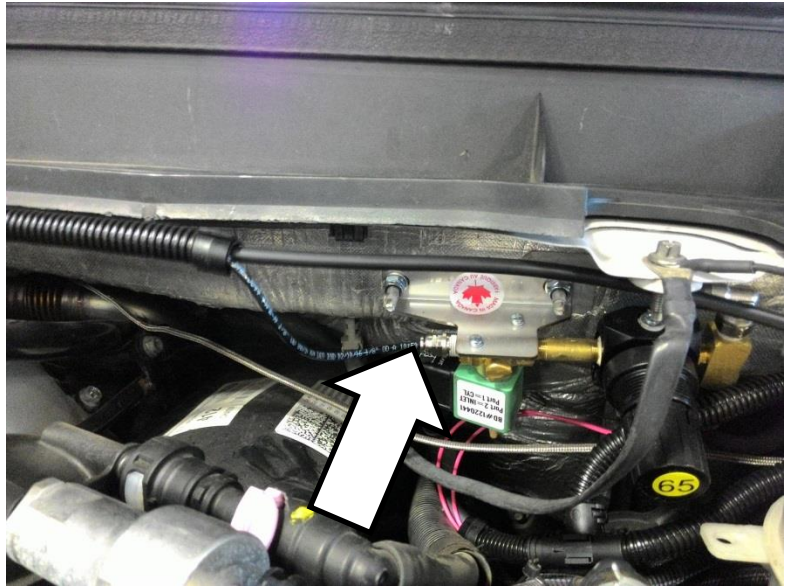

The other 1/4" tube from the brake valve is the vent line. If this is to be trimmed, remove the air filter and reinstall after cutting. Allow it to run past the air regulator assembly, towards the driver side to a dry location under the hood.



Locate the 1/4" air supply tube from the air compressor (this is the one without the air filter fitting on the end). Connect this to the top fitting on the air regulator assembly.

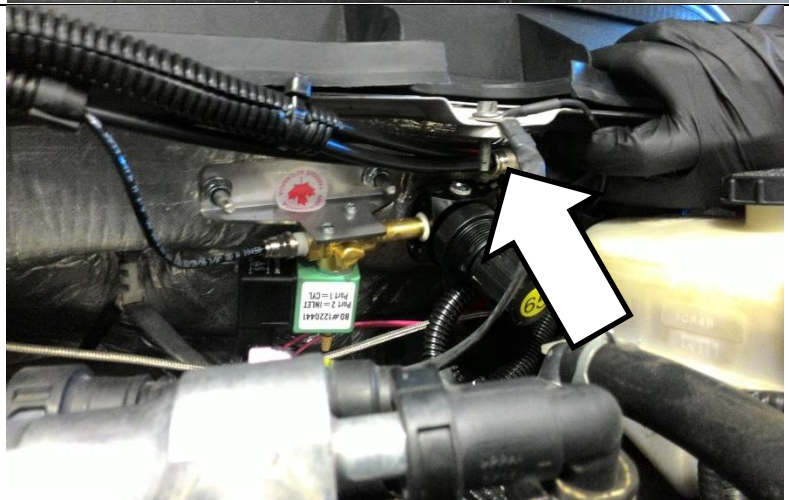

The other line from the air compressor is the suction line, this has the push on fitting to NPT adapter. Thread the supplied “pancake” filter into this fitting hand tight. This is the filter that came with the air compressor.



Position this line with the air filter and the other vent line in the corner of the engine bay, away from significant sources of heat or moisture.

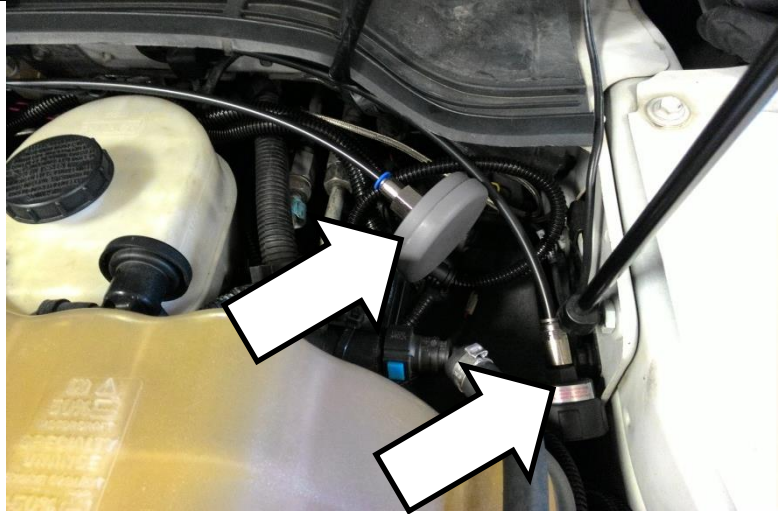

Connect the pump power wires from the pump loom to the control kit wiring harness. If the airlines have been trimmed, you may need to coil up excess wire.



Refer to the wiring and plumbing diagram for more details.

Control Module Installation

In the cab, remove the OBD port connector from below the dash using a 7mm socket and ratchet.

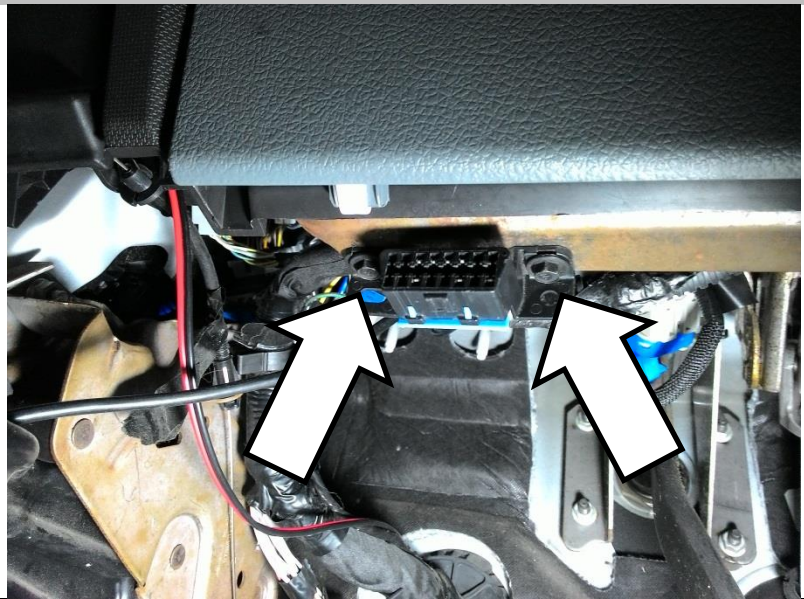

Plug the supplied BD control module wiring harness (1304575) in line with this connector and screw the BD harness back in place of the original connector.

Note This OBD connection does not need to be disconnected for flash programming so it can be left installed permanently.



Below the dashboard, locate the up fitter switch wires. These are the four wires located above the e-brake bracket, up by the firewall. Do not mix these up with the larger bundle of wires for the up fitter PTO functions which is below.

If all of the upfitter switches are already in use, you will need to provide your own switched 12v power for the control module.

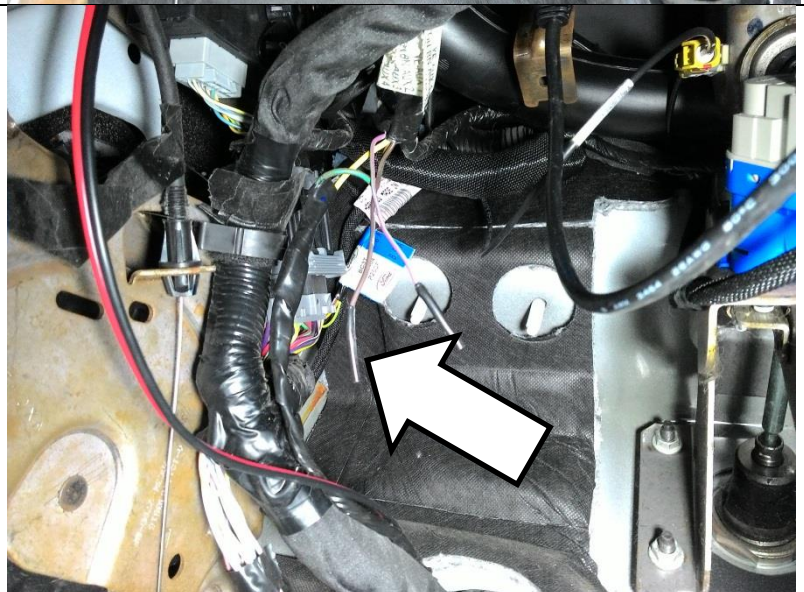

Ford Up fitter AUX Switch Wire Colors (2011-2016)

AUX1	25AMP	YELLOW
AUX2	25AMP	GREEN/BROWN
AUX3	10AMP	VIOLET GREEN
AUX4	15AMP	BROWN

Separate and locate the wire from the switch you wish to use. We recommend using AUX4. This is the BROWN Wire. Strip the end of this wire and install the supplied posi-lock connector. (If the AUX switches are all used for other purposes, you will need to supply your own switched 12v power)

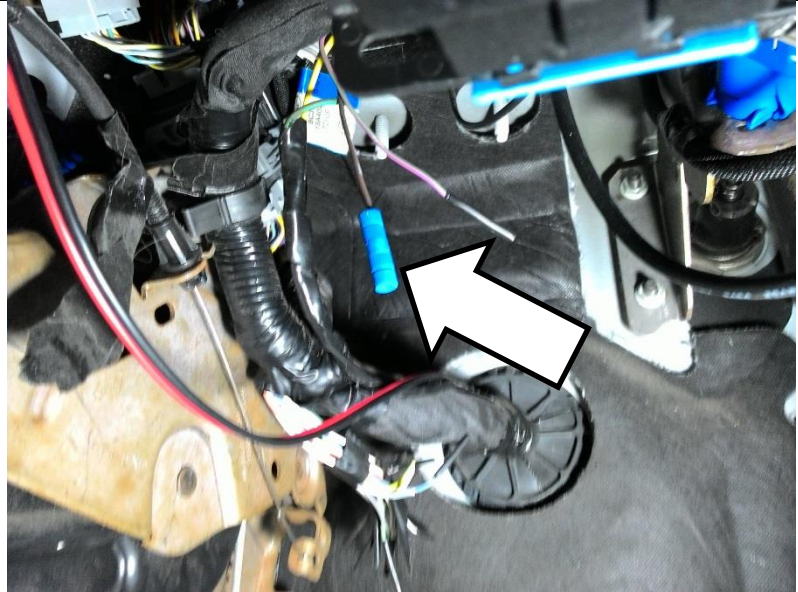

Connect the other side of the posi-lock connector to the RED wire from the BD controller harness. This will supply switched power to the control module.

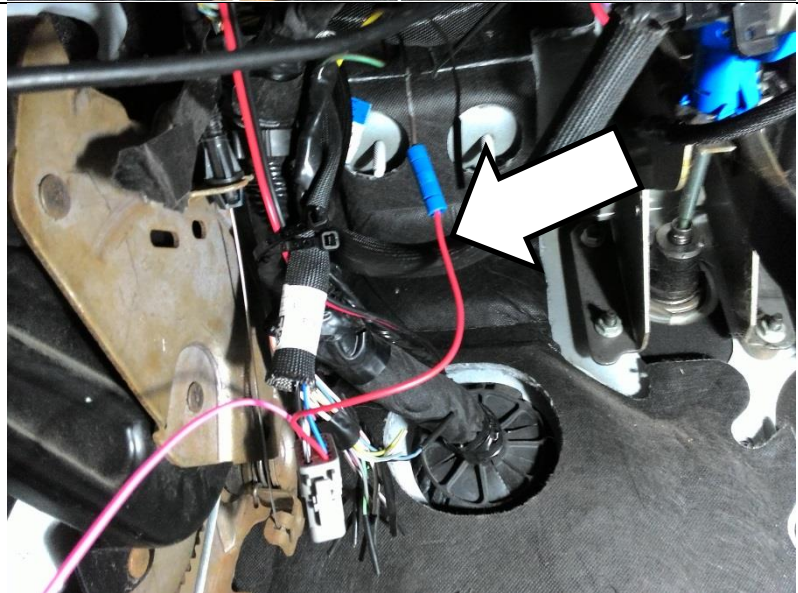

Fish the pink wire from the BD controller harness thru the firewall into the engine bay.

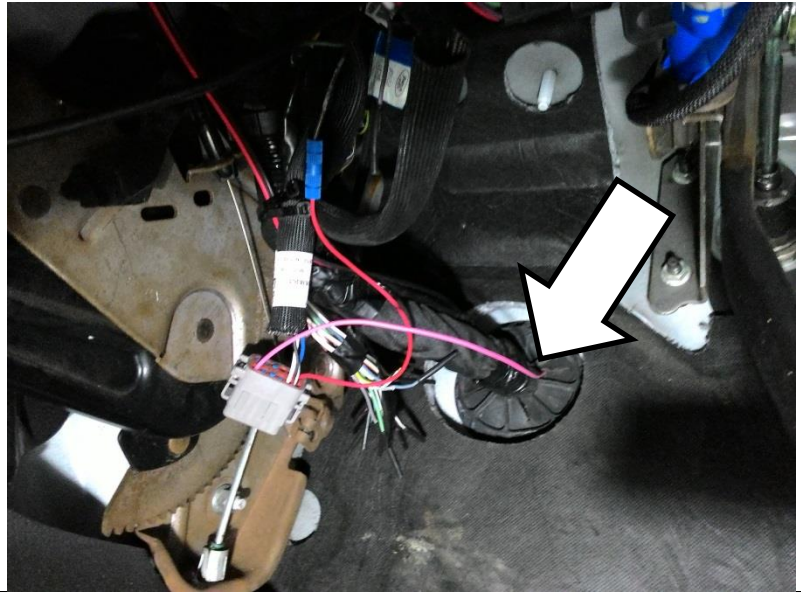

Locate the PINK wire from the regulator/control assembly in the engine bay. This will be a loose wire with a pre-installed heat shrink butt connector on the end. Connect this wire to the PINK wire from the control module wiring harness.



Crimp the butt connector and use a heat gun or lighter to heat-shrink this connection.

Plug the control module (1304570) into the control harness under the dashboard and secure the module with zip ties below the dashboard.



Apply the included exhaust brake decal to the AUX switch used to identify it as the exhaust brake switch.

Note The decal is clear with white text, so ensure the switch is clean and apply it carefully to avoid air bubbles visible under the sticker.



Refer to the wiring and plumbing diagram for more details.

Exhaust Brake Controller Modes

The control module has two features that may be enabled or disabled depending on customer preferences. These settings are stored in memory and are not lost when the truck is powered off.

Warmup Mode

When the engine is cold, running the exhaust brake during idling will help speed up engine warmup. The module can command the exhaust brake on when the truck is idling and is not moving. This feature is disabled by default and can be enabled / disabled by the following procedure.

Turn the key ON (do not start).

Turn on the exhaust brake switch.

Push the throttle pedal to the floor and release it three times.

You will hear the brake valve stroke and release one or two times.

If it cycled one time warmup mode is now off, if twice warmup mode is now on.

Repeat the throttle pedal press procedure to toggle the mode.

Full vs Auto Exhaust Brake Mode

When the throttle pedal is released, the exhaust brake will normally engage right away (“full” on). This is the default and normal operation of the exhaust brake. Some drivers prefer to be able to coast when they let off the throttle pedal, so this module also has an “auto” mode which will turn on the exhaust brake only after the brake pedal has been pressed. This means that you need only give the brake pedal a light tap and the brake will come on. This feature can be changed by the following procedure.

Turn the key ON (do not start).

Turn on the exhaust brake switch.

Tap the brake pedal three times.

You will hear the brake valve stroke and release one or two times.

If it cycled one time the brake is now in “full” mode, if twice it is now in “auto” mode.

Repeat the brake press procedure to toggle the mode.

Module Version Info

V1.0 – First release

V1.1 – Altered load/throttle control strategy to reduce exhaust brake cycling.

Wiring & Plumbing Diagram

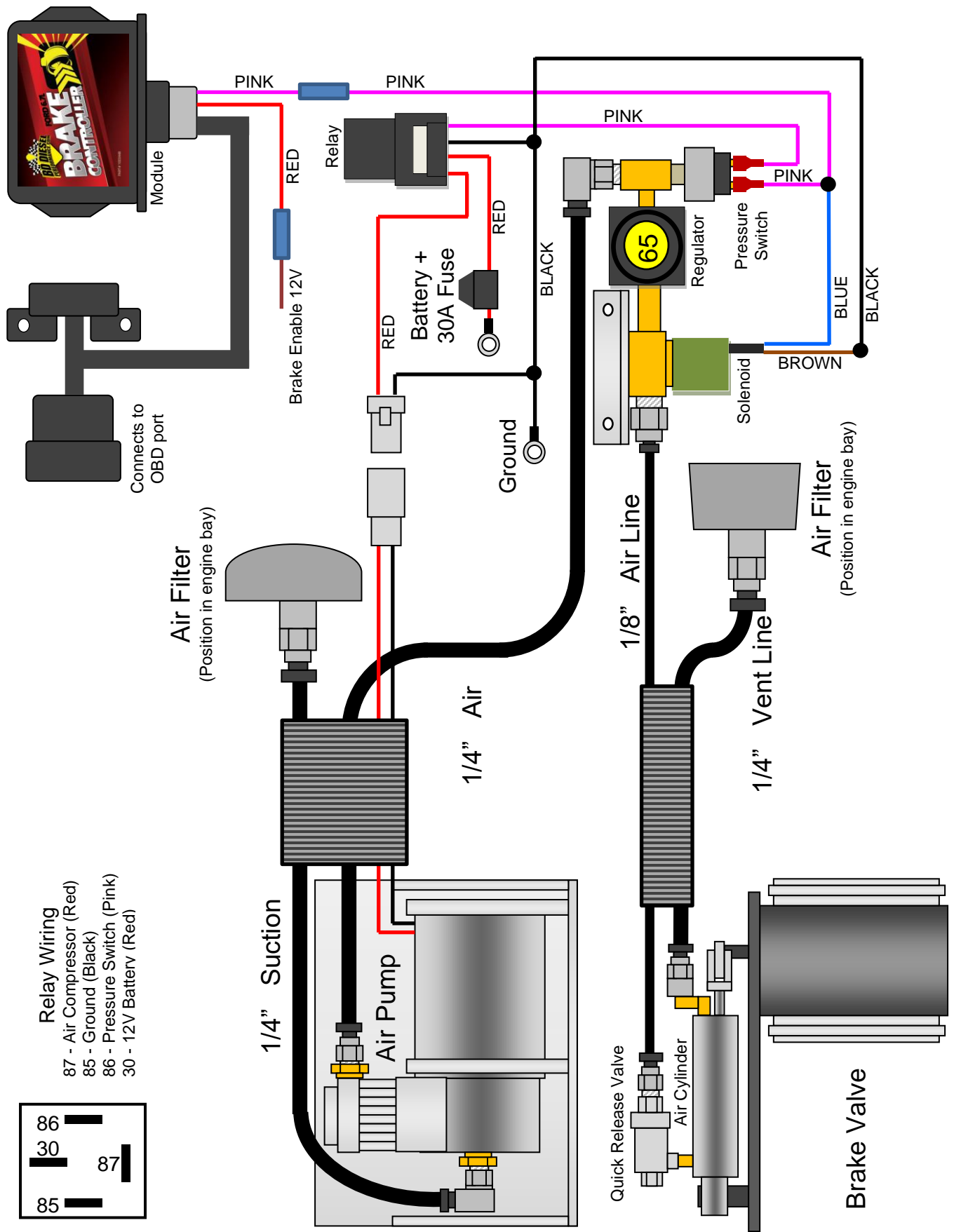

- Relay Wiring**
- 87 - Air Compressor (Red)
 - 85 - Ground (Black)
 - 86 - Pressure Switch (Pink)
 - 30 - 12V Battery (Red)
- | | |
|----|----|
| 86 | 87 |
| 30 | 85 |

Exhaust Back Pressure Testing for Air Actuated Brakes

To test exhaust brake system pressure, a minimum 0-100psi pressure gauge is required.

We recommend purchase of a BD brake pressure gauge kit #1030050.



To test the idle pressures, the exhaust brake must be applied at idle. If the engine is cold and warmup mode is enabled, the brake will turn on when at idle, otherwise it must be commanded manually.

To turn the brake on for testing, turn on the exhaust brake toggle switch, remove the cover from the control module and press the “TEST” button inside. Pressing this button will energize the brake air solenoid and run the pump as necessary.

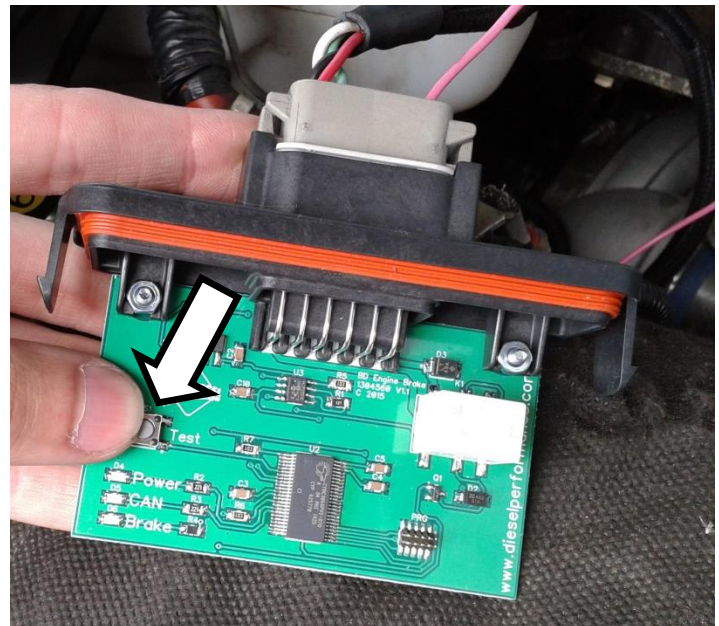

You do not need to measure the air pressure in the system, just the exhaust backpressure, which is located on the cast valve.

Idle Pressure Test

With the BD brake engaged and the engine at idle check the exhaust backpressure using a pressure gauge (such as BD PN 1030050) at the test port on the brake valve.

If the back pressure is below 13 psi at idle you have a number of likely causes. The most common being an exhaust leak either at the clamp joint or at the welds (only on some models). Apply the exhaust brake and have someone assist you looking for soot trails or the visible leak. Another culprit would be an exhaust manifold leak, turbocharger gasket leak, turbocharger problem or an EGR issue.

If the back pressure is greater than 25psi, you will need to make an adjustment on the stop bolt. Loosen the jam nut, and lengthen the stop bolt towards the actuator, this will shorten the stroke distance. Only turn 1/4 rotation at a time and re-secure the jam nut. Retest idle pressure.

NOTE: The brake stop-bolt and regulator have been preset at the factory and should not need to be adjusted.

We generally do not recommend adjusting the stop bolt, please consult BD before doing this as it may void your warranty.



Off-Idle Pressure Test & Adjustment

Your BD exhaust brake is a variable-orifice design so when the brake is active and the engine is at higher RPM the brake lever does not rest on the stop bolt. Off-idle backpressure is set by adjusting the air pressure regulator which will in turn increase or decrease off-idle exhaust backpressure. You will need to secure your pressure gauge somewhere that you can see it while you are driving. Using a long extension hose & bringing the gauge into the cab through an open window or clipping it under a windshield wiper works well.

Get the truck up to speed (a downhill grade or a load in the truck is helpful) and activate the exhaust brake. Note the maximum backpressure achieved. You should get peak backpressure at higher RPM (try 3000 RPM in Drive). If you cannot reach the desired backpressure (compare table below) you can begin troubleshooting, the first step is to look for exhaust leaks either from the clamps, exhaust manifolds or feed pipes. Also look for leaks at the clamps located at the back of the turbo and also at the down pipe. If all connections are sealed, you can then use the adjusting regulator to increase the backpressure. Note that small regulator adjustments can have a significant effect on off-idle backpressure.

Turning the regulator **clockwise** will increase pressure.

Turning the regulator **counter clockwise** will decrease pressure.



NOTE: Over the next two weeks, the backpressure at idle may rise due to initial carbon build up on the inside of the brake housing and on the butterfly. The stop bolt may need to be adjusted again to compensate.

Application	Maximum Back Pressure
GM/Chevy 6.5	35 psi
GM/Chevy Duramax	55 psi
Ford Powerstroke 6.0L	45 psi
Ford Powerstroke 6.7L	65 psi
Dodge Cummins 1988-98 12V w/o 60lbs Springs	40 psi
Dodge Cummins 1988-98 12V with 60lbs Springs	60 psi
Dodge Cummins 1998 to current	65 psi

*HD Spring part# is 1030060.

CAUTION: Do NOT exceed the maximum back pressure value in the exhaust system. Exceeding this pressure will force the exhaust valves open during the intake stroke which could cause engine damage.

Maintenance

To extend life of the exhaust brake, do not operate the vehicle for extended periods of time without activating the brake. We suggest activating the exhaust brake at least a couple times a day while operating the vehicle to prevent any carbon or rust build up on inner parts of the brake valve assembly.

The hoses, wires, fittings and clamps should be inspected on a regular basis for any deterioration, damage or leaks.

To increase the life of your exhaust brake, we recommend daily operation. By simply switching the brake on and off a couple times a day, it will prevent the butterfly valve from sticking due to carbon build-up.

Following the diagrams in this manual, tracing hoses and wiring, checking continuity through electric components or checking for any lines that are disconnected, should solve any problems that may arise. If you have any problems or need replacement parts, call us at 1-800-887-5030.

Troubleshooting

This guide assumes that your exhaust brake system is using a “Ford 6.7L Brake Control Module” rather than a DFIV or micro-switch on the throttle. For other systems see the appropriate instruction manual.

Brake does not engage	No	Yes
<p>Is the control module powering the trigger output wire?</p> <p>Open module and observe the "BRAKE" led, this will light when the module activates the output.</p>	<p>Is the module powered? Check the fuse box for blown fuse.</p> <p>AUX1 – Fuse 94 25A AUX2 – Fuse 95 25A AUX3 – Fuse 9 10A AUX4 – Fuse 2 15A</p> <p>Check wiring harness for connection or for damage.</p> <p>Also check power & ground at pump relay</p>	<p>Check that when air solenoid is powered it will allow air to flow from the #2 port out the #1 port.</p> <p>Check that pump relay is powering pump. If pump has power but does not run, pump is likely faulty. Check for power & ground at pump relay, if these are good but relay does not click or does not power pump, relay is likely faulty.</p>
The brake comes on but there's little or no holdback	No	Yes
<p>Check off idle brake pressure. (See back pressure chart) Are you getting maximum allowable backpressure at full RPM?</p>	<p>Check for exhaust leaks. A small leak can result in a significant decrease in back pressure. If no leaks are found try adjusting air regulator. Check for air leaks in brake system.</p>	<p>Try down shifting more aggressively. More RPM will give more holdback. Transmission or torque converter could be slipping internally.</p>
Everything seems to work, but the brake valve won't close	No	Yes
<p>Check that air is reaching brake air cylinder?</p>	<p>Air solenoid or quick release valve are likely stuck, plugged or faulty. Clean or replace as required.</p>	<p>Cylinder or brake valve are seized. Remove the clevis pin on the end of the cylinder rod & see if the valve lever can be moved freely.</p>
<p>The valve lever can be moved freely?</p>	<p>Try dismounting the brake & cleaning the carbon out of it. If this does not work the brake valve will need to be replaced.</p>	<p>The cylinder is stuck and will need to be replaced.</p>
Problem	Solution	
<p>Air compressor runs in short bursts and brake is slow to apply.</p>	<p>There is a restriction in the air system, normally in the regulator or air solenoid. Remove the fittings from the regulator and air solenoid, you will likely find some corrosion or debris caught in them. Clean this out with a pick, small brush, compressed air and WD40 or similar lubricant.</p>	
<p>Air compressor runs continually.</p>	<p>Pump relay is likely stuck on. Check operation of relay & replace as required.</p>	
<p>Brake is slow to release.</p>	<p>Debris or corrosion is restricting the quick release valve or air solenoid. Clean as required.</p>	

Thank you and happy motoring.
BD Engine Brake, Inc.