



**DOWNLOAD THE LATEST
INSTALL MANUALS AT
www.bddiesel.com**



Fuel Heater Installation Manual





1050346	Heater for BD FlowMax
1050347	Heater for AirDog 1, 2, 2-4G, 2-5G & Fass “Red Base”
1050348	Heater for FASS

PLEASE READ ALL INSTRUCTIONS BEFORE INSTALLATION

KIT CONTENTS

Please check to make sure that you have all the parts listed in this kit

1050346 – HEATER KIT FOR THE BD FLOWMAX SYSTEM

1500343	1500342	1302174	1500375
			
Heater Qty: 1	Nut; 3/4"-16 Qty: 1	Thread Lock (BLUE) Qty: 1	Adapter Qty: 1

1500420

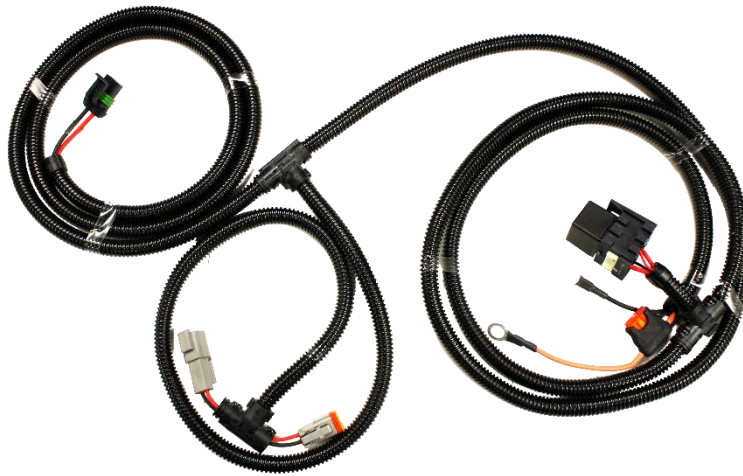

Harness; Fuel Heater for BD Flowmax

Qty: 1

Optional Accessories:







1050350 - WIF Sensor 2000-07 Dodge 5.9L

1050351 - WIF Sensor 2007-12 Dodge 6.7L

1050347 – HEATER KIT FOR THE AIRDOG & FASS RED BASE			
1500343	1500342	1500376	1500407
			
Heater	Nut; 3/4”-16	Adapter (AirDog 1)	Adapter (2 & 2-4G & 2-5G)
Qty: 1	Qty: 1	Qty: 1	Qty: 1
1500424	1500425	1500427	1302174
			
Harness; Fuel Heater for FASS/AirDog (Long)	Harness; Pump Adapter (2021-)	Harness; Pump Adapter (2021+)	Thread Lock (Blue)
Qty: 1	Qty: 1	Qty: 1	Qty: 1

**** Fass Red Base requires the use of P550550 water separator or equivalent**

1050348 – HEATER KIT FOR THE FASS SYSTEM

1500343	1302174	1500377
		
<p>Heater Qty: 1</p>	<p>Thread Lock (Blue) Qty: 1</p>	<p>Adapter Qty: 1</p>
1500424	1500425	1500426
		
<p>Harness; Fuel Heater for FASS/AirDog (Long) Qty: 1</p>	<p>Harness; Pump Adapter (Pre Dec 2018) Qty: 1</p>	<p>Harness; Pump Adapter (Post Dec 2018) Qty: 1</p>

Introduction

The BD FlowMax Fuel Heater is an add on accessory for the BD FlowMax fuel lift pump system. It installs in conjunction with the BD 1050340-WSP water separator filter assembly or on the inlet filter of an AirDog or FASS pump. The supplied wiring harness automatically triggers the heater on when the fuel pump is running.

Cold diesel fuel is susceptible to waxing or gelling. This solidification causes the fuel filter media to become partially clogged leading to fuel delivery issues. Fuel heaters help keep diesel fuel warm to prevent this problem and ensure a continuous fuel supply regardless of ambient temperature.

The BD Fuel Heater installs between the incoming fuel supply and the water separator filter, heating the cold fuel as it enters the filter. The BD Fuel Heater is a 320W high power heater, far outperforming the competition. As the temperature drops the heater output increases to help maintain fuel temperatures. As the fuel temperature rises, the heater reduces its output to reduce wasted heat generation.

Installation:



***FILTER REPLACEMENT AT THE TIME OF THE HEATER
INSTALL IS ALWAYS RECOMMENDED.***

1) Remove water separator filter and adapter from head if installed.

2) Install fuel heater threaded adapter (#1500375) into the Flowmax water separator head.

Use supplied thread lock to secure fitment.

Tighten with 1" wrench. *Do not over tighten.*

5 ft/lbs is sufficient.

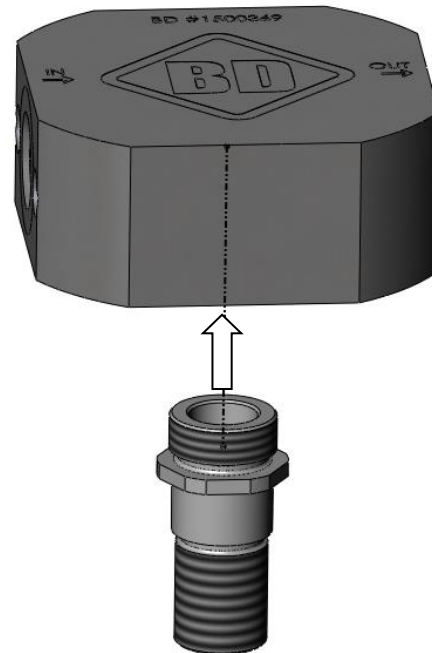

3) Heater connection on a BD Flowmax System

- a) Lubricate sealing ring surface with engine oil. Place sealing ring into heater receiving groove and slide the heating unit (#1500343) up against the filter head.

NOTE: It is suggested to replace the sealing ring when replacing the water separator.

Dodge# 4429695

Cummins# 3913695

Fleetguard# 3834185S

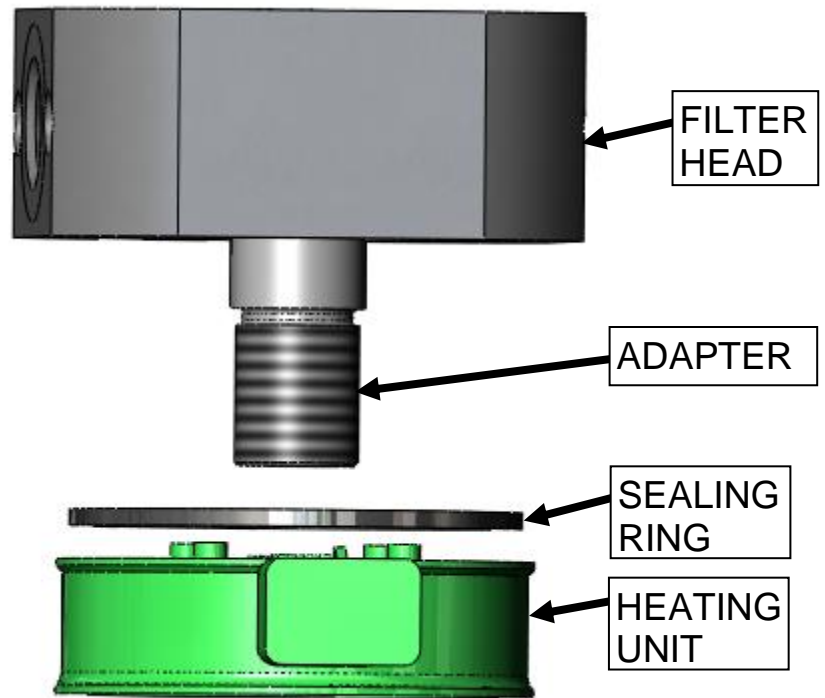

- b) Place a dab of blue thread lock onto the adapter then, thread the supplied panel nut (#1500342) onto the threaded stud, thereby securing the heater in place.

Ensure to orientate the wiring connector in the desired direction that is away from water spray or flying debris.

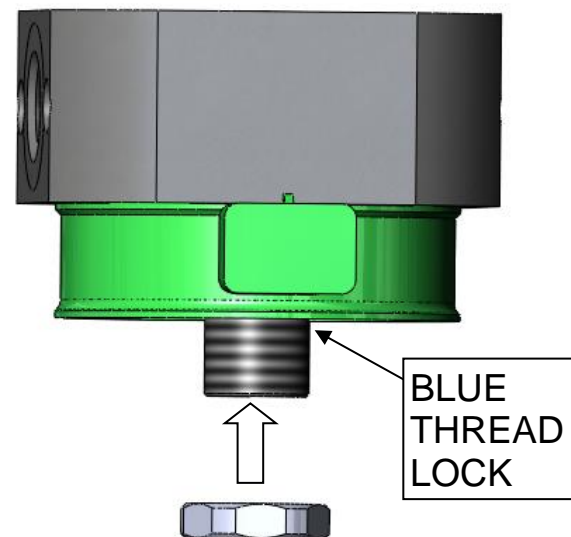

IMPORTANT: Clean excess thread locker from the exposed threads before installing filter otherwise the filter may be difficult to remove at the next service interval.

4) Heater connection on an Air Dog & Fass Red Base System

- a) Lubricate sealing ring surface with engine oil. Place sealing ring into heater receiving groove and slide the heating unit (#1500343) up against the filter head.

Pump	Adapter
Air Dog 1	1500376
Air Dog 2	1500407
Air Dog 2-4G	1500407
Air Dog 2-5G	1500407
Fass Red Base	1500376

NOTE: It is suggested to replace the sealing ring when replacing the water separator.
 Dodge# 4429695
 Cummins# 3913695
 Fleetguard# 3834185S

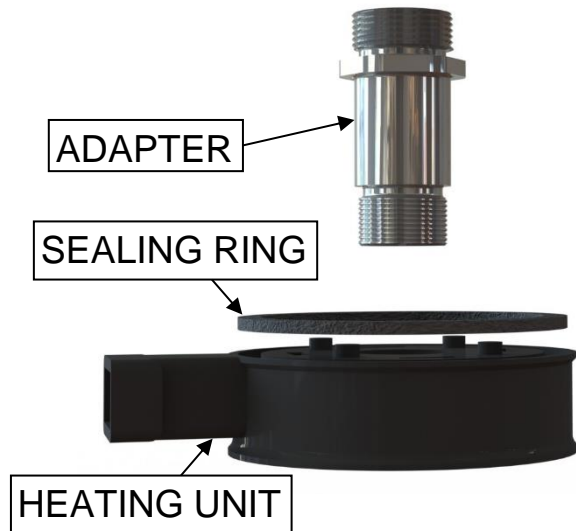
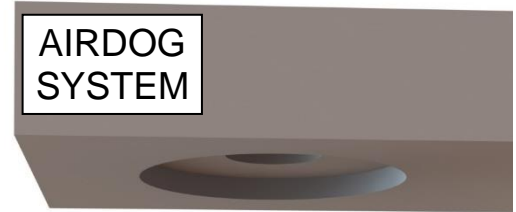

- b) Place a dab of blue thread lock onto the adapter then, thread the supplied panel nut (#1500342) onto the threaded stud, thereby securing the heater in place.

Ensure to orientate the wiring connector in the desired direction that is away from water spray or flying debris

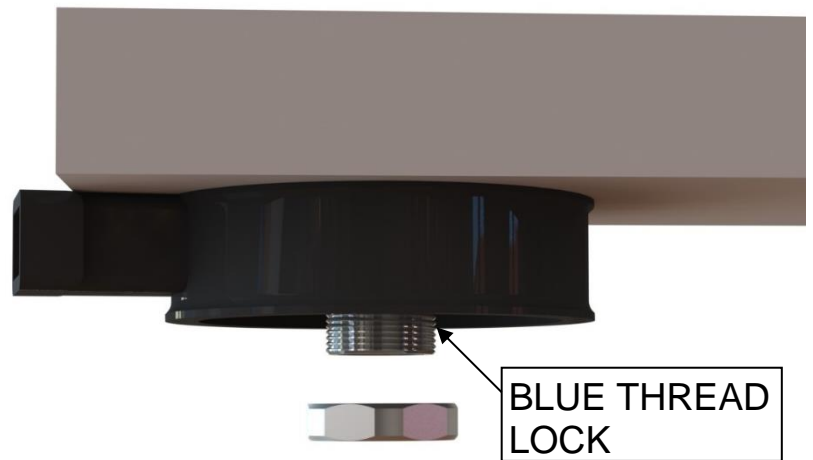

IMPORTANT: Clean excess thread locker from the exposed threads before installing filter otherwise the filter may be difficult to remove at the next service interval.

***Special note for red base Fass system**

NOTE:

BD Fuel Heater kit requires the use of a P550550 filter or equivalent (see table). Originally supplied FASS filter will not fit with the adapter and heater.

Manufacturer	Part #
BD	P550550
Air Dog	WS100
WIX	33616

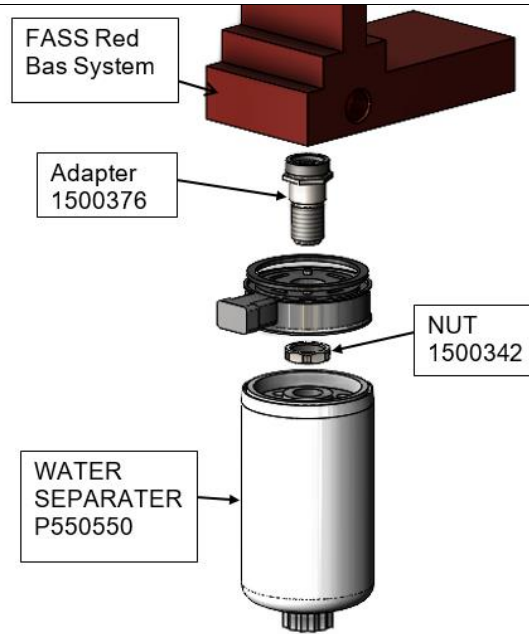

5) Heater connection on a FASS System

- i) Apply Blue LOCKTITE to the threads (refer to picture)
- ii) Install seal into the PTC Fuel Heater

NOTE: It is suggested to replace the sealing ring when replacing the water separator.

Dodge# 4429695
 Cummins# 3913695
 Fleetguard# 3834185S

- iii) Hold PTC Fuel Heater up against the filter head and secure with the provided adapter (1500377)

Ensure to orientate the wiring connector in the desired direction that is away from water spray or flying debris

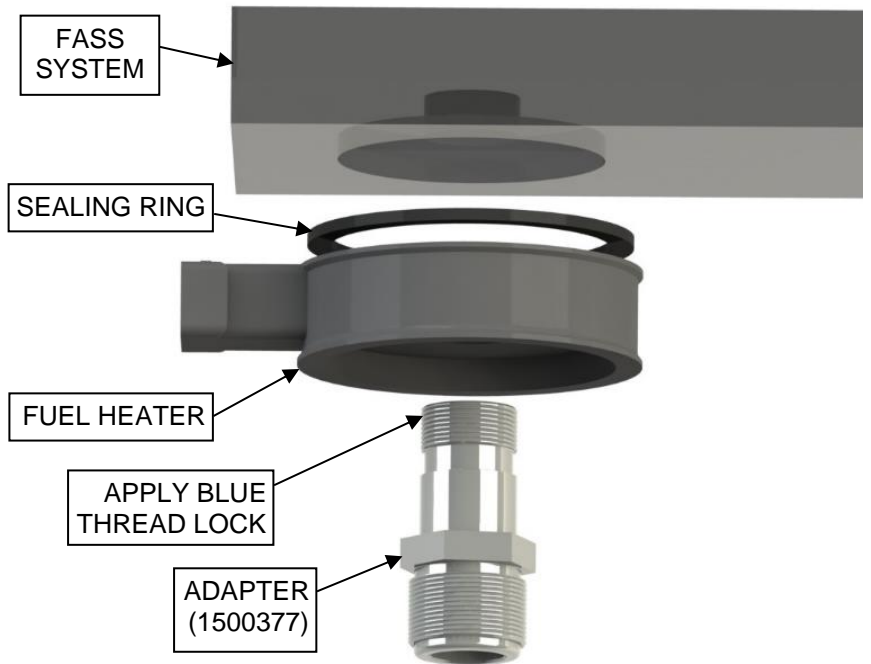

IMPORTANT: Clean excess thread locker from the exposed threads before installing filter otherwise the filter may be difficult to remove at the next service interval.

- 6)** Lubricate the sealing ring of the water separator filter before installation.

Thread filter onto threaded stud. Do not overtighten.

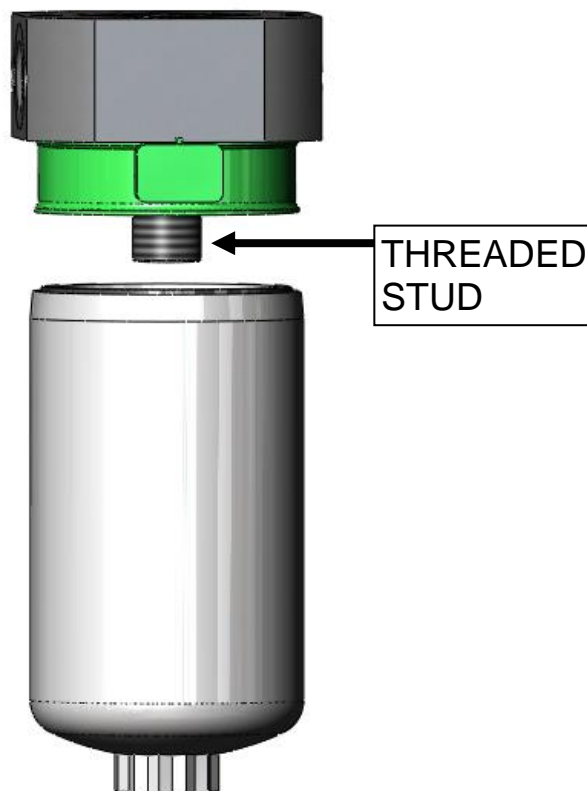

- 7)** Insert heater wiring harness wiring connector into heater.

- 8)** Connect the fuel heater harness to the fuel pump harness, this will serve as a trigger for the fuel heater relay.

For FASS and AirDog applications select the appropriate adapter

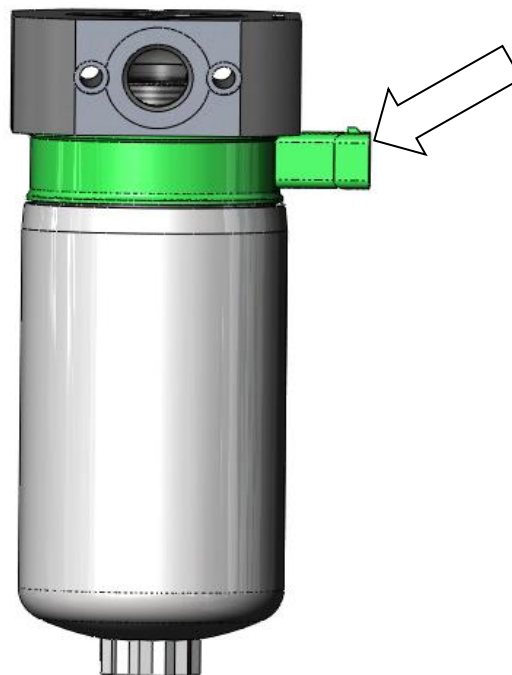

Wiring Connections for FlowMax

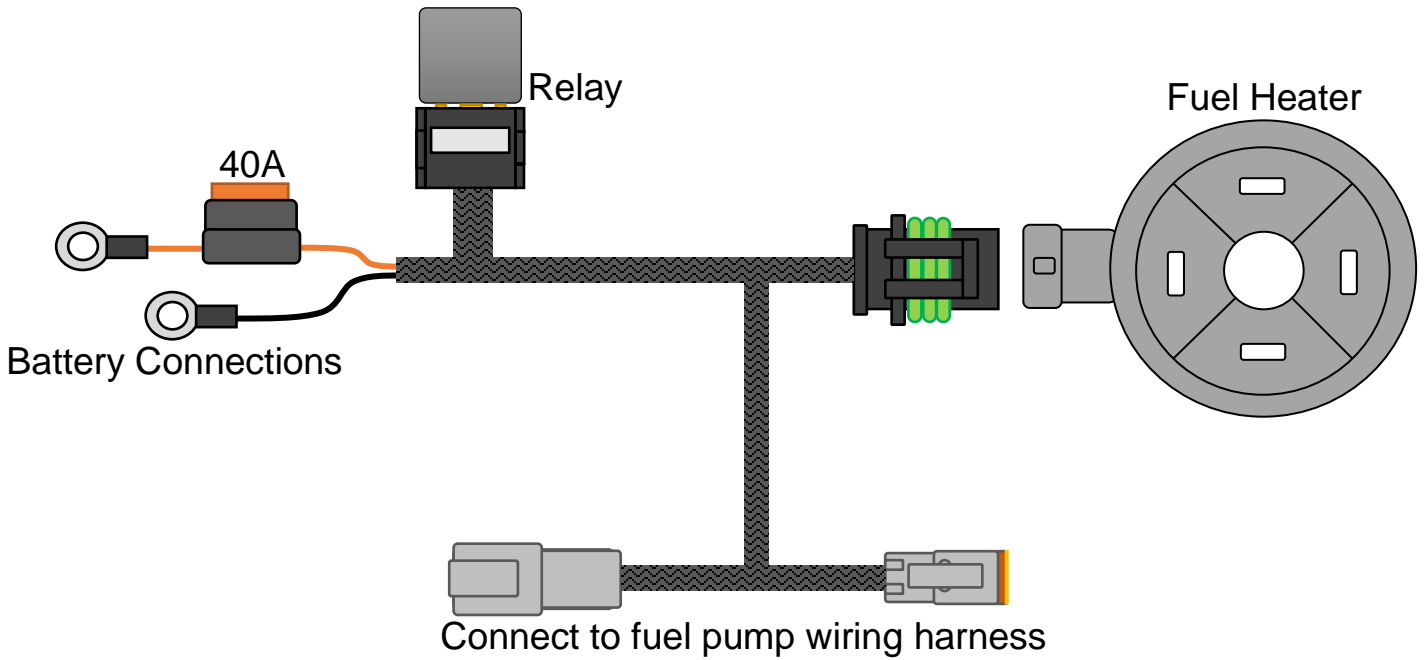

Wiring Connections for FASS / Air Dog

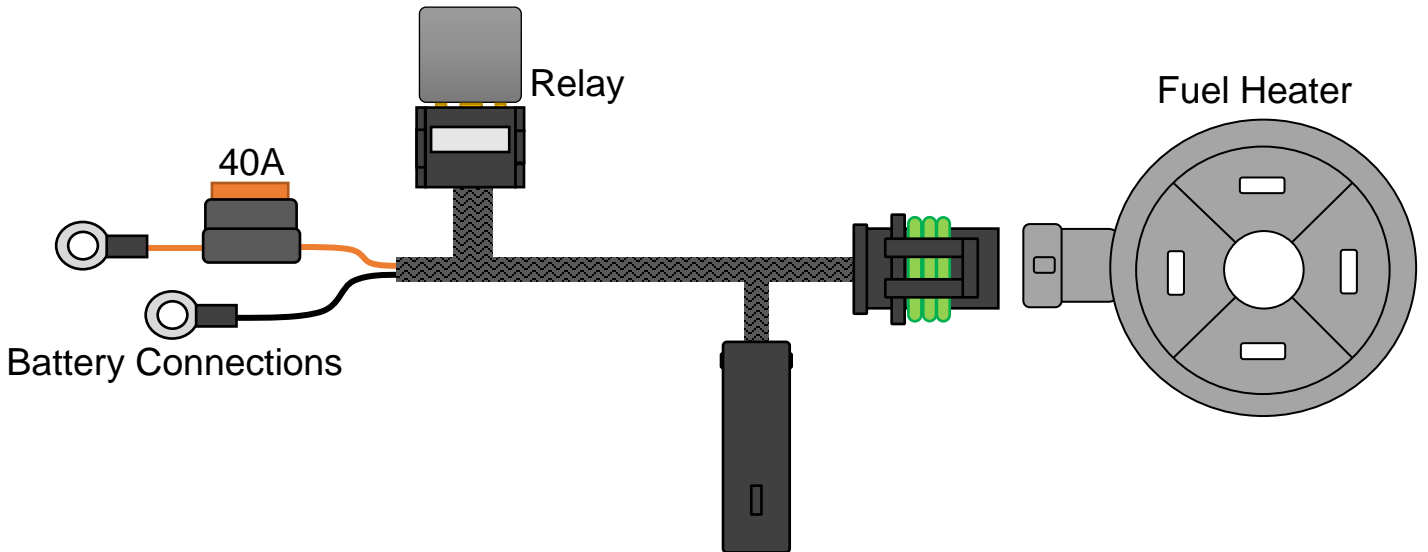

2018- FASS, 2020- AirDog

2019+ FASS

2021+ AirDog

