



**DOWNLOAD THE LATEST
INSTALL MANUALS AT
www.bddiesel.com**



PN: 1031369

1031369



2003-2007 Ford 6.0L F250-F350





The TapShifter **MUST** be disconnected from the OBD connector when changing ECM/TCM/FICM programming.



This kit is not intended for E-series vans or on gasoline engine applications. Excursions have exhibited some compatibility issues and are not recommended.

Kit Contents

1607241	1607233	1607232
		
6L TapShifter Module	Interior Harness (Gray plug)	Transmission Harness (Black plug)
Qty: 1	Qty: 1	Qty: 1

1607239	BC3Z-7210-BA	1607245Z
		
Gear Display Module	Shifter Handle	Shift Handle Adapter
Qty: 1	Qty: 1	Qty: 1

1210365	1210363	FT-11289222
		
Butt Connector 18-22ga	Butt Connector 14-16ga	Shift Handle Screw
Qty: 7	Qty: 1	Qty: 1

1330054	1300131
	
Double Sided Tape	Tie Wrap (Medium)
Qty: 1	Qty: 12

2003-2004 Tow/Haul Led Install Parts



1300285	1003344	1801123
		
Posi-Lock (Blue)	Tow/Haul Decal	Amber LED
Qty: 2	Qty: 1	Qty: 1

Table of Contents

- Kit Contents2
- 2003-2004 Tow/Haul Led Install Parts2
- Table of Contents.....3
- Introduction3
- Operation4
- Tools Required for Installation4
- Installation.....5
- Shift Lever Installation.....5
- Tap Shifter Display10
- OBD Connection.....11
- Transmission Wiring12
- Module Installation.....18
- Optional VVB Switch Wiring.....19
- Wiring Layout.....19
- User Adjustments.....20
- Troubleshooting21
- Compatibility22
- Module Version.....22
- Transmission Adaptive Learning.....22

Introduction

BD’s Ford 6.0L TapShifter kit gives you control over your automatic transmission with just the touch of a button.

2003-2007 Ford 6.0 vehicles with a 5R110 transmission have only one automatic drive mode and three manual gears from factory. This does not allow the driver to disable overdrive nor does it allow for convenient engine braking.

The BD Ford TapShifter kit comes with a new Ford shift lever which goes in the stock location for a sleek install. In addition, it comes with a small display module which installs on the dash to show the selected gear.

This kit has a built in high pressure VVB (variable vane brake) function. It can close the turbocharger vanes during deceleration generating exhaust backpressure which helps to slow down the vehicle. The performance of this brake rivals even the conventional butterfly valve type exhaust brake.

This kit is perfect for street performance, towing and racing. There are different modes the module can operate in, allowing everything from normal gear liming to manual torque converter lockup control and engine braking capabilities.

Operation

Shift the vehicle into drive (D). Press the down '-' button on the shift lever. The BD display will now light up with the current gear the vehicle is in. The driver can now press up '+' and down '-' to increase and decrease the maximum gear.

The truck will now shift automatically through the gears, stopping at the selected gear. This works just like most late model vehicles.

To disable the TapShifter, just press the '+' button until the display turns off. Otherwise the TapShifter system will automatically turn off any time the shift lever is moved out of the drive position.

Alternate operational modes are built into the module which allows for manual control of lockup in ALL gears, manual gear control and different shift points. See "User Adjustments" at the end of this manual for more information.

The VVB exhaust brake feature of the module is enabled anytime the TapShifter is turned on unless a separate switch has been installed (see "Optional VVB Switch Wiring" at the end of the manual). It will automatically close the turbocharger vanes during deceleration creating exhaust backpressure which will aid in decelerating the vehicle. To maximize braking force, downshift the transmission for higher engine RPM. The chart below shows the approximate exhaust backpressure attainable using the TapShifter with VVB.

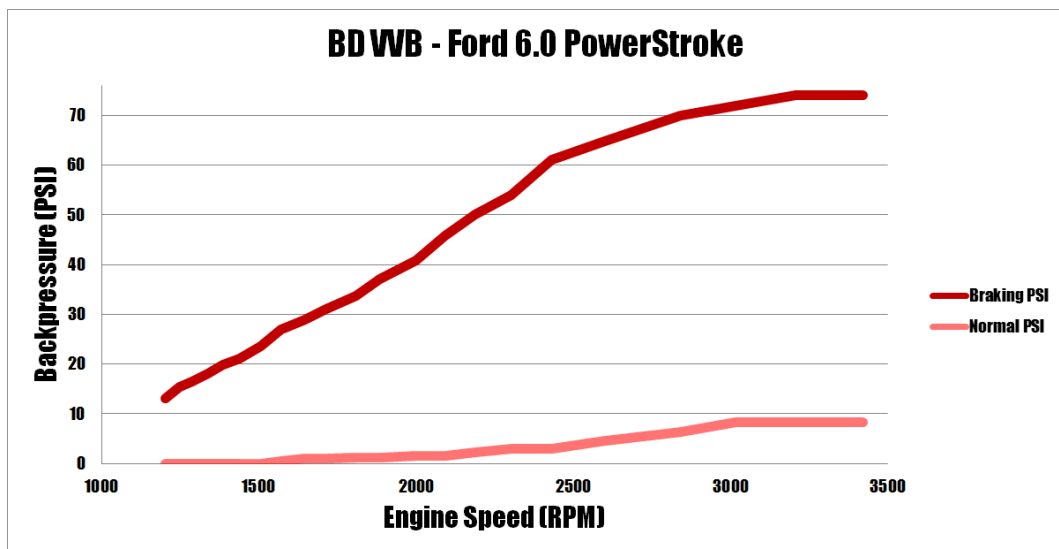

Tools Required for Installation

- Wire strippers
- Wire crimpers
- Utility knife
- Torx T30
- Phillips Screwdriver
- Pick tool
- Hammer and punch
- 7mm, 8mm socket and ratchet

Installation

Read and familiarize yourself with the entire installation procedure before beginning. Ensure you have the tools required before starting. Chock the wheels as the transmission will be shifted out of park during installation. Some sections of this manual are specific to particular model years. They will be labelled as such in each step.

Disconnect both vehicle batteries before beginning installation.



Remove the knee bolster below the steering column.

On 2003-2004 models, rotate the four flat head fasteners a quarter turn.

On 2005-2007 models, simply pull the knee bolster out of the clips.



Shift Lever Installation

To remove the steering column covers, begin by removing the three Philips screws.



To remove the upper cover the ignition lock cylinder must be removed. Insert a long pick or similar tool into the hole beneath the switch and push upwards while rotating the key to the on position.



When the key is in the on position and light pressure is maintained on the pick, it should be possible to slide the ignition lock cylinder out of the steering column.

NOTE: When the lock cylinder is removed, do not rotate it as this will make reassembly more difficult.



Remove the top half of the steering column cover by pulling it apart from the bottom and lifting it off and over the shift lever handle.

NOTE: The bottom steering column cover may be left in place.



Release the shifters rubber boot from the two hold down clips. Unplug the shift lever electrical connector.

Slide the boot up the shift lever out of the way.

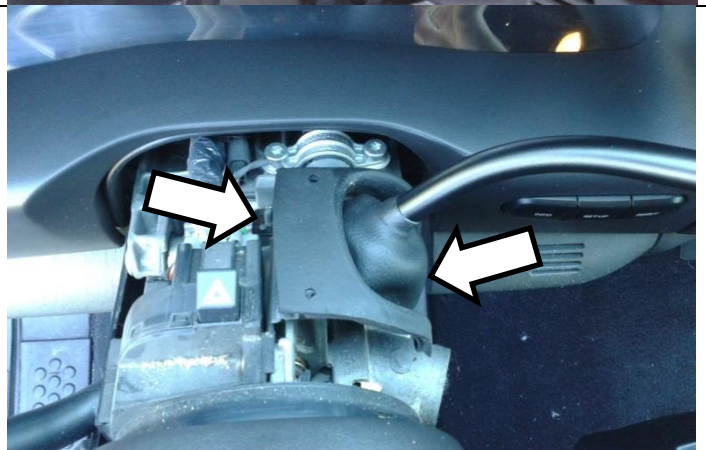

Using a punch and a hammer, drive the “press in pin” out of the shifter assembly. This will allow the shifter handle to be removed from the vehicle.



If the original shift lever had a rubber bushing on the end of the shift lever transfer it to the new shift lever adapter. If not, disregard this step.

Ford introduced this bushing in later model years to reduce shift lever play.



Insert the new shift lever adapter supplied with this kit into the steering column shifter assembly. Reinstall the “press in pin” with a small hammer.

Pay close attention to the orientation of the adapter. It should be installed so that the angled face faces the dash and the flat side faces the driver. The tapered screw hole should point down.



The shift lever supplied with this kit has a rubber boot already installed on it, however it will not fit the truck as it is.

Cut off the hard plastic section leaving only the triangular shaped rubber boot.



Install the new shift lever into the shift lever adapter. Slide the boot back on the shift lever to allow access to the mounting screw.

Install the supplied Torx screw into the adapter. The screw head should be facing downwards.

Torque Specification: 13 ft-lb



Locate the 1607233 wiring harness provided with the kit. Route the shift lever connectors pictured here up to the steering column.



2006-2007 Models

Connect the 5 pin connector to the shift lever and connect the oval three pin connector to the stock wiring connection. The rectangular three pin connector and the individual red and black wires are not used for these model years.

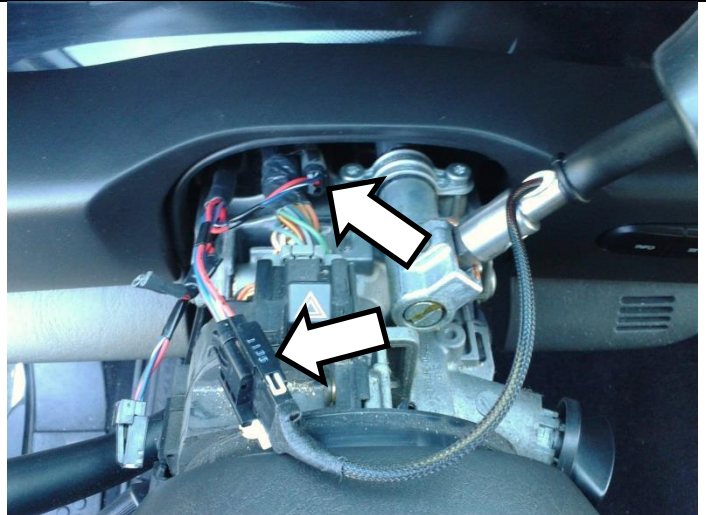

2003-2005 Models

Connect the 5 pin connector to the shift lever and connect the rectangular three pin connector to the stock wiring. The oval three pin connector is not used on these applications. For 2003-2004 models, continue to the additional steps below.

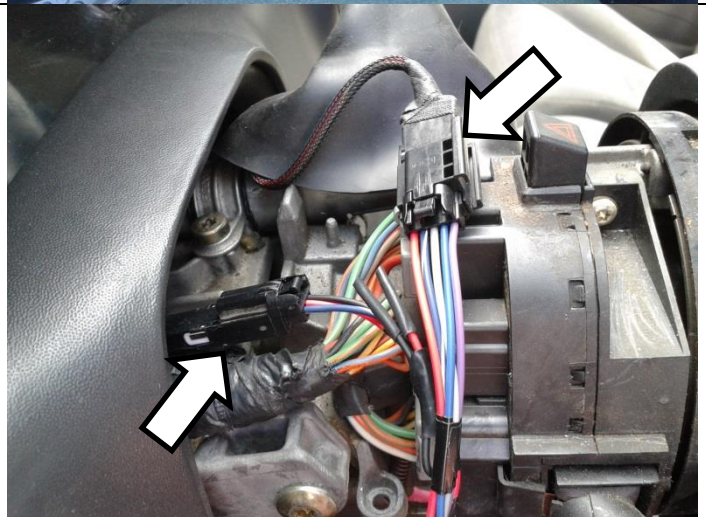

2003-2004 Models Only

As the early model 6.0L trucks had the Tow/Haul indicator inside the shift lever rather than in the instrument cluster, it is necessary to add a separate indicator lamp.

Drill a 1/4" hole to mount the supplied LED in the location shown. The LED installation location should be visible to the driver.



2003-2004 Models Only

Stick on the Tow/Haul decal supplied with the kit, centered over the mounting hole.

Insert the led wires through the hole and install LED.



2003-2004 Models Only

Separate the red and black wires from the shifter harness and cut off the heat shrink ends. Strip the wire ends.

On later model years, leave these wires taped up.

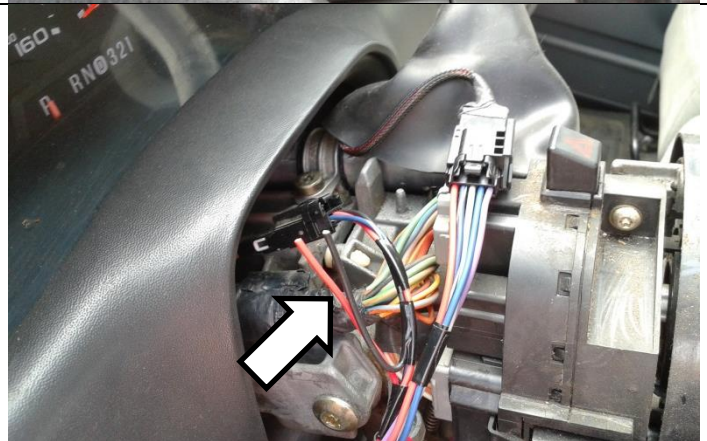

2003-2004 Models Only

Install the supplied blue posi-lock connectors onto the red and black wires and connect them to the red and black wires from the LED.

Alternatively, these connections can be soldered but the posi-locks allow for easier service in the future.

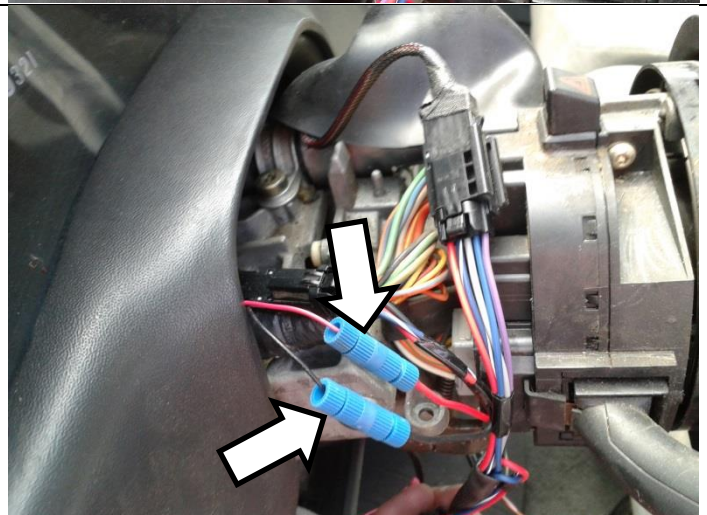

The shift lever wiring must be carefully secured to reduce chances of failure due to pinching or chafing.

Move the shift lever all the way to 1st and secure the shifter wiring so that it will not be too tight in this position.



Move the shift lever through the gears and make sure the wire does not get pinched.

Suggested wire tie locations shown.

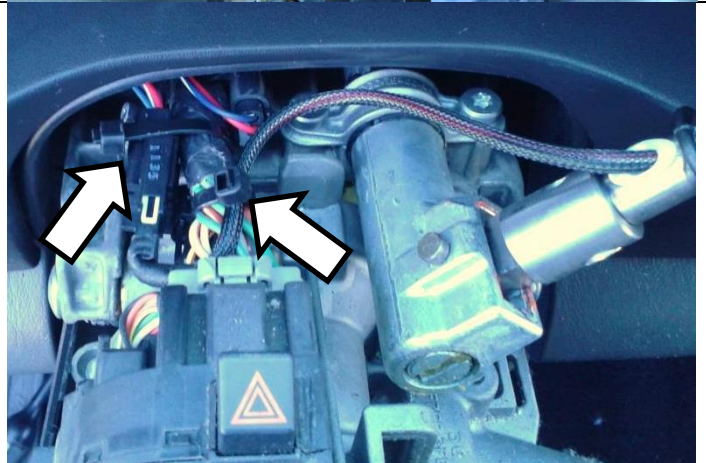

Flip the rubber boot back down onto the steering column. Slide it down the shifter handle.

NOTE: The boot may appear a bit too large at first, but it should not be trimmed until tested for fitment. The large boot size helps ensure it will not pop out when the shift lever is moved.



Tap Shifter Display

The BD TapShifter display module may be mounted in any desired location that the wires will reach. The following instructions are the suggested normal installation method.



Route the display module wiring up from below the dashboard to the top of the steering column. Reinstall the column covers and reinstall ignition lock cylinder by inserting it back into the column.

Plug the display module into the wiring harness and stick it down with the supplied double sided tape.



This location for the display is generally suggested as it does not block the gauges for most driving positions.

The installer may choose a different location if it suits them better. The display wires can also be extended if desired.



OBD Connection

Remove the two 7mm mounting screws from the OE connector and install the BD connector in place.

Connect the OBD connector from the wiring harness to the vehicles OBD connector.

IMPORTANT: If flash programming the ECM, PCM or FICM disconnect the TapShifter from the OBD connection.



The OBD connection can be left in place if simply changing tune “power levels” on the fly, but if left connected during an ECM/PCM/FICM flash program/update it will cause the connection to be interrupted. If this is a concern, the original OBD connector can be left in place and the TapShifter wiring tied out of the way. This way it will be obvious to others that there is a device connected to the OBD port.

Transmission Wiring

The transmission wiring harness must be run from below the dashboard to the powertrain control module in the engine bay.

2005-2007 Models

There is a block off foil plate installed on the firewall where the clutch master cylinder would normally mount. Peel back the adhesive to feed the wires from in the cab to the engine bay and pull through.

View is from engine bay side.



2003-2004 Models

Remove the plastic block off plate for the clutch master cylinder cutout. Notch it to fit the wiring harness. Feed harness through firewall and reinstall plate.

View is from the engine bay side.

NOTE: Do not install in the rubber grommets below as it will be more difficult to disconnect this harness for cab-off service.

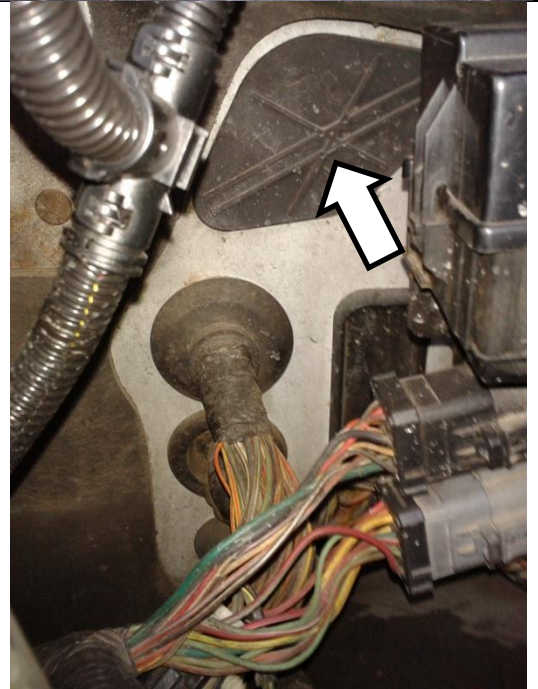

Remove the driver's side battery cover by releasing the clips on the sides of the cover.



Remove the 8mm screw holding down the battery and remove it to get better access to the PCM.

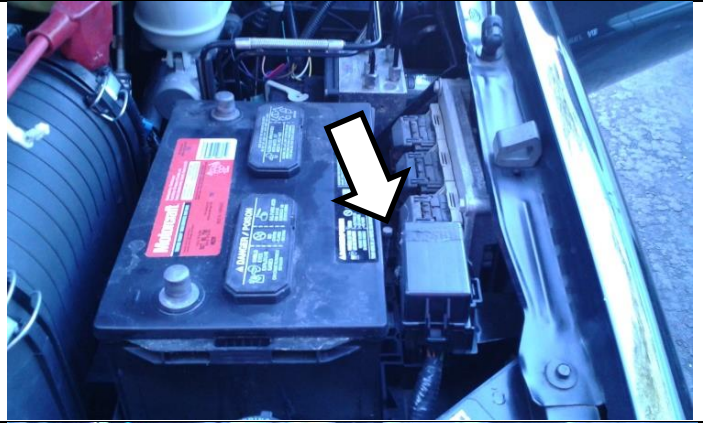

Remove the smallest of the three PCM connectors (towards the front of the vehicle) by releasing and rotating the gray lever lock.

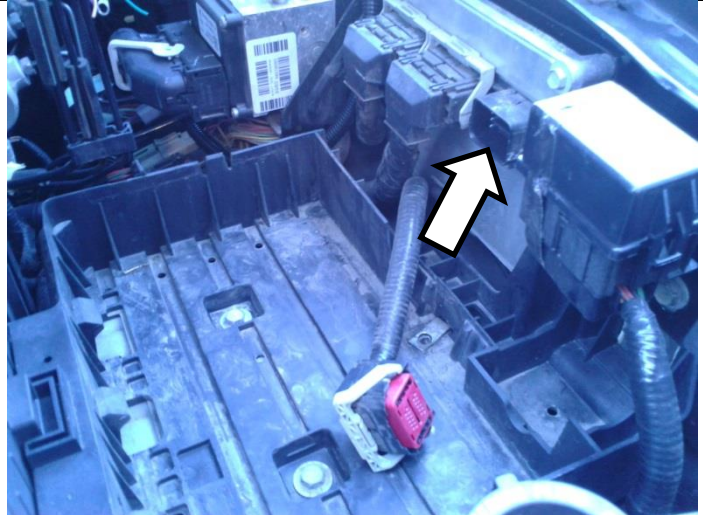

Remove the back shell from the connector using a small pick or screwdriver to release the four latching tabs. This will allow a clear view of the pin locations for the wiring.



Remove the electrical tape from the wire loom to expose the wires. About six inches is sufficient to work with.

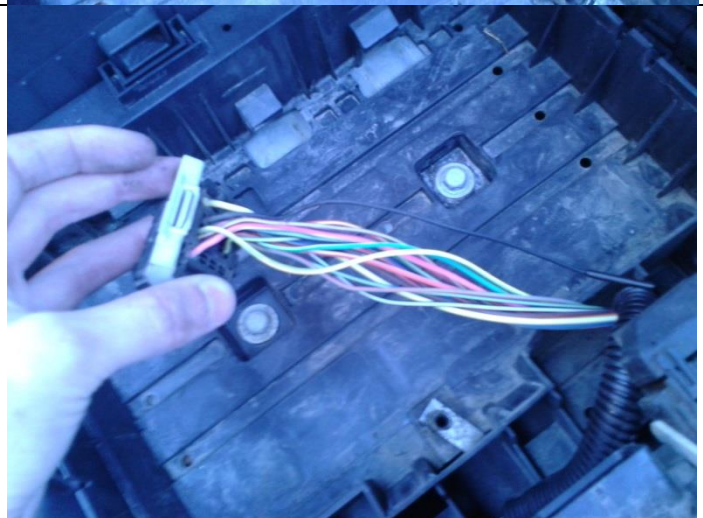

Make the wire connections as shown in the following diagrams using the supplied heat shrink butt connectors.

IMPORTANT: Use extreme care when locating the wires. Always check the pin number on the connector as some wire colors look similar or discolor with age. An incorrect connection here could cause damage. Additionally, verify the pin-out in the BD black connector to ensure they are correct.

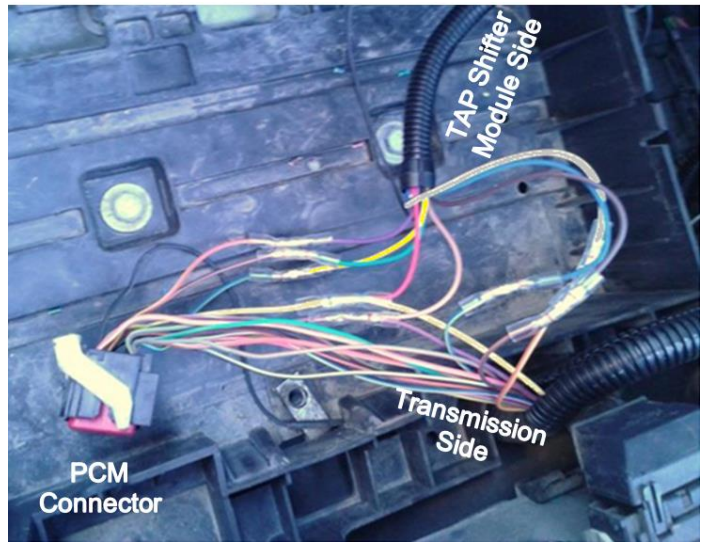

Heat shrink the butt connectors for a water tight seal.

BUTT CONNECTOR NOTE:

The kit is supplied with one 14-16awg (blue stripe) butt connector for the “Solenoid Power” circuit (Yellow/White wire). The remainder of the circuits are to use the 18-22awg (red stripe) connectors.

Transmission PCM Connector (Rear View)

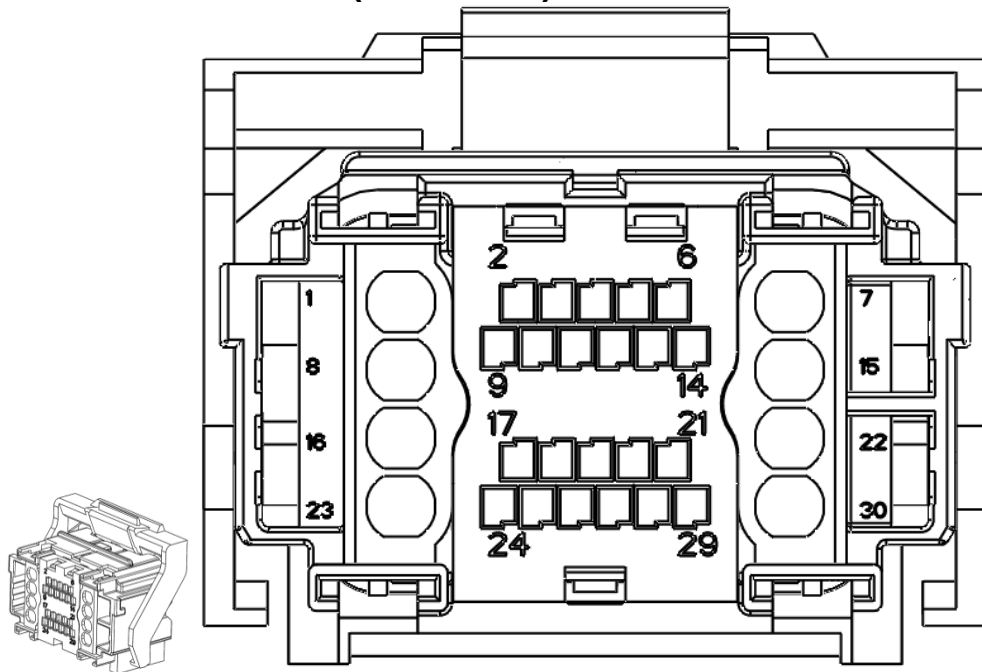

Pin Number	Wire Color	Function
7	Yellow/White	Solenoid Power
9	Orange/Yellow	Coast Clutch Solenoid
10	Violet/Orange	Overdrive Solenoid
14	Brown/Orange	TCC Solenoid
25	Light Blue/Yellow	Range Sensor

TapShifter Module Black Connector (Rear View)

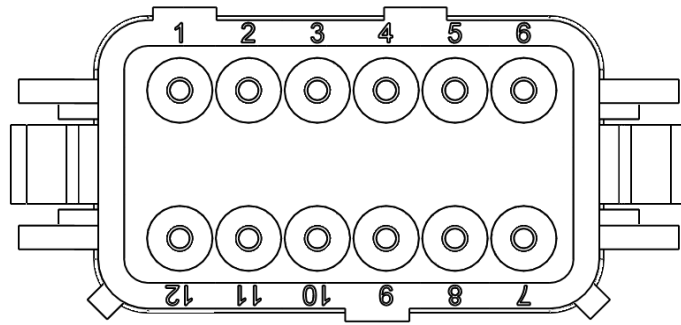

Pin Number	Wire Color	Function
1	Black	Ground (Chassis)
2	Red	Solenoid Power
3	unused	
4	Violet	Coast Clutch Solenoid to PCM
5	Green	TCC Solenoid to PCM
6	Yellow	Range Sensor to PCM
7	Blue	Range Sensor to Transmission
8	Brown	TCC Solenoid to Transmission
9	White	Coast Clutch Solenoid to Transmission
10	Tan	Overdrive Solenoid Sense
11	Pink	12V Reference for VVB Enable
12	Pink	VVB Function Enable (See end of manual for more information)

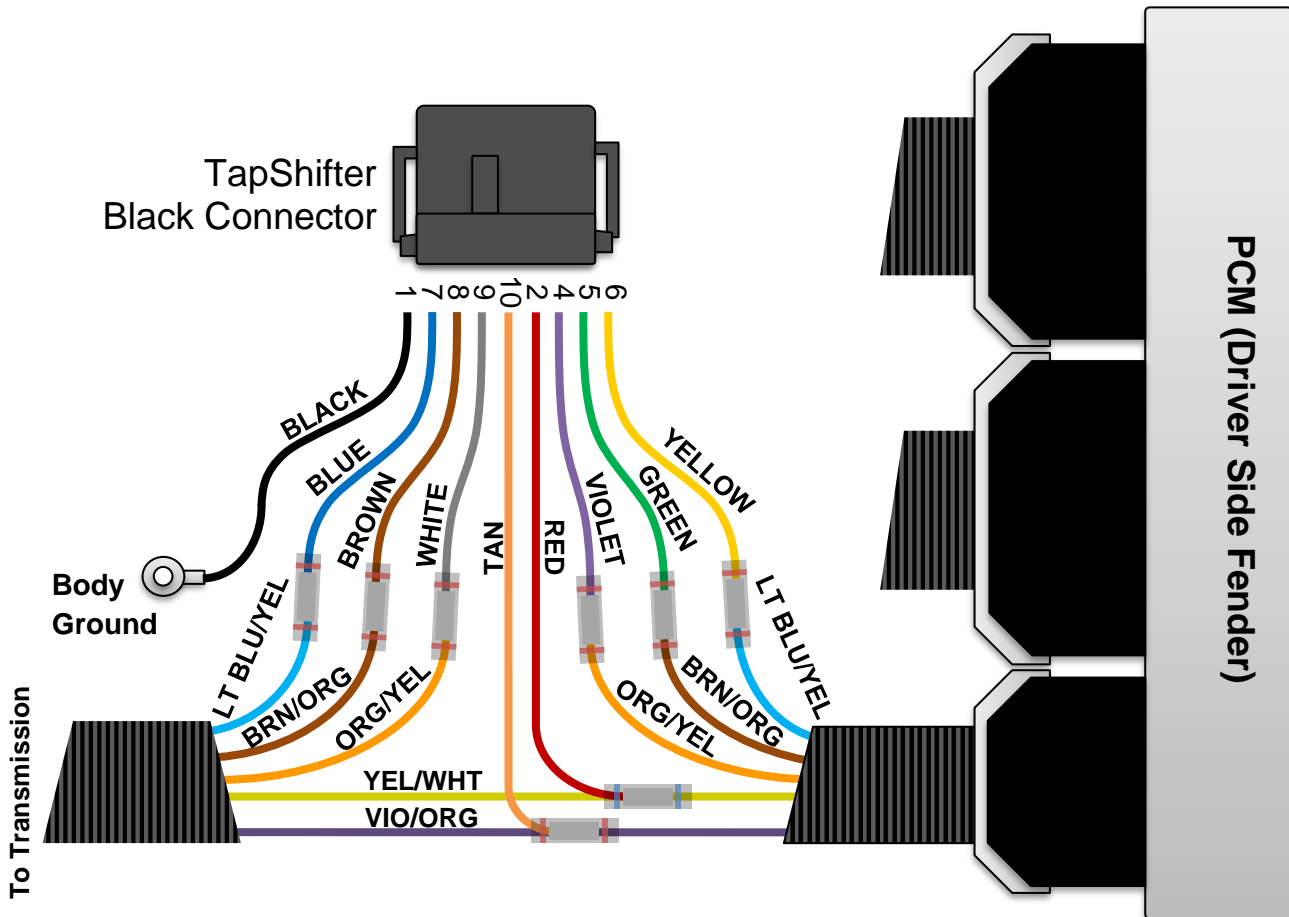

Incorrect electrical connections at the PCM are the number one cause of problems with this product. You may wish to test system operation before reinstalling the wire loom and taping up the wiring harness. The most common wire mixup is selecting the light blue/yellow OEM wire for the range sensor. This wire often fades to a gray color and is easy to mistake with another similar colored wire in the harness.

To quickly check the connection to the range sensor:

- Complete installation and put the batteries back in place
- Turn the ignition to on (engine off).
- Put the shift lever in drive
- Try to turn on the tap shifter by tapping the '-' button.
- If the tapshifter does not turn on check the wire and refer to troubleshooting.
- If the tapshifter turns on only momentarily and turns back off this indicates the Yellow and Blue wires from the BD harness are reversed.
- If the tap shifter turns on normally then the Yellow and Blue wires from the BD harness are likely correctly connected to the factory range sensor signal wire.

Use electrical tape to loom up the wires and slip the original wire loom over the connections. Leave the black wire with ring terminal from the BD kit to hang outside of the harness. This will be connected to a body ground.



Reinstall the connector into the PCM.

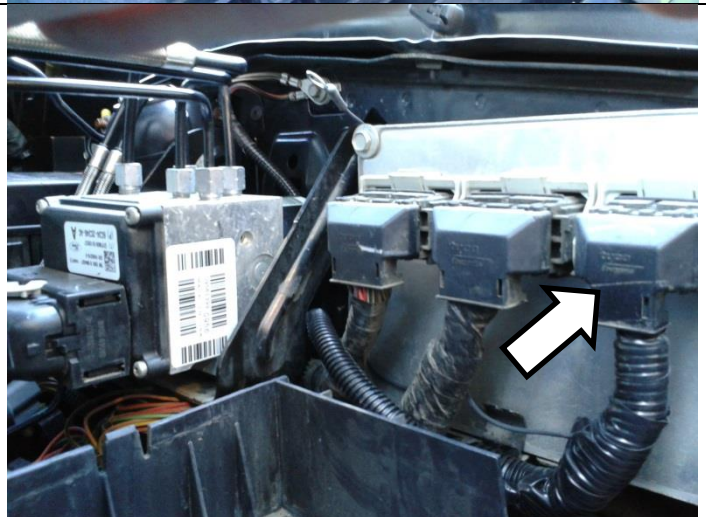

2005-2007 Models

Route the black wire with ring terminal from the BD harness to the body ground just to the rear of the PCM, near the ABS module. Remove the existing screw and reinstall with the ring terminal.



2003-2004 Models

Route the black wire with ring terminal from the BD harness to the body ground ahead of the PCM, behind the headlamp. Remove the existing screw and reinstall with the ring terminal.

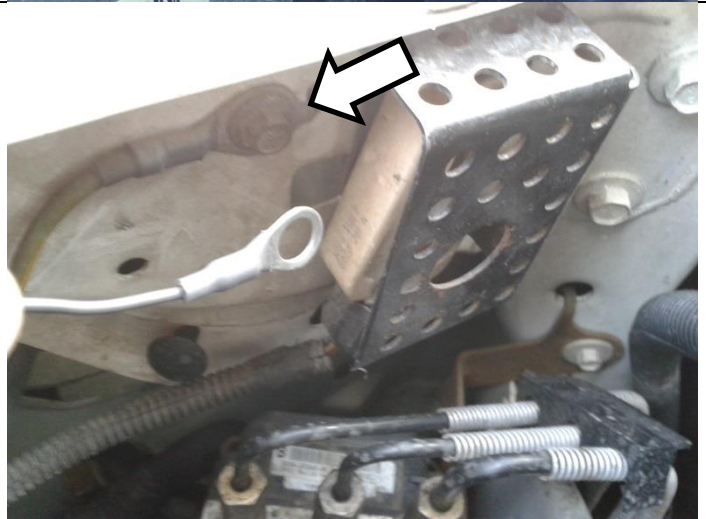

Reinstall the battery into the battery tray. Install the battery hold down clamp.

Reinstall the battery cover on top of the battery.

Module Installation

Connect the control module to both the gray and black connectors.

Install the control module beneath the dashboard and tie it in place with zip ties.



Reinstall the knee bolster.
Check that no parts are still left disassembled.

Reconnect both batteries.

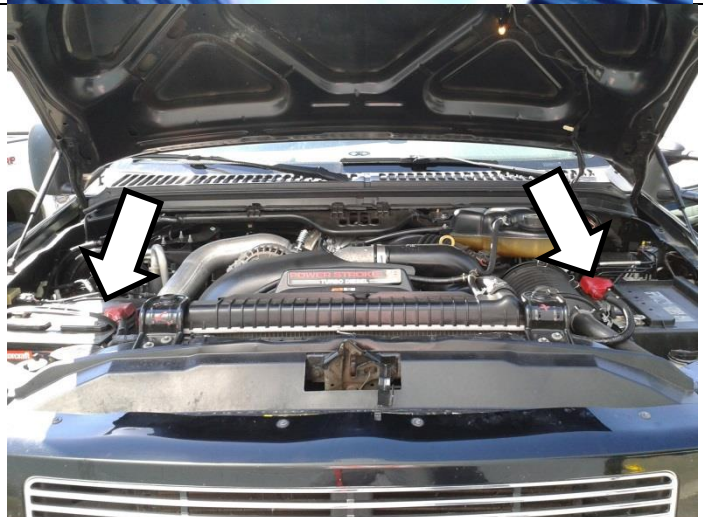

Installation should now be complete.
Test the system for operation.

The shift lever boot may be adjusted if necessary for cosmetic purposes.



Optional VVB Switch Wiring

This TapShifter kit has a built in "VVB" exhaust brake function that closes the turbocharger turbine housing vanes when the throttle is released to aid in deceleration. By default this is active whenever the tap shifter is turned on. If the operator wishes to be able to control this function manually, a very simple wiring modification can be made in the kits wiring harness at the module.

To enable the VVB, 12 volt power must be fed to the module through pin 12 of the black connector. The wiring harness comes with a short pink jumper wire installed between pins 11 and 12 to enable the feature all the time. The installer may install a switch or integrate it with the Ford Up-fitter switches if desired. See wiring diagrams below.

Always enabled – Connect pins 11 and 12

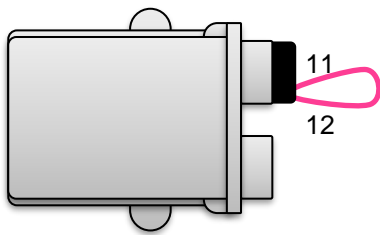

Switch controlled – Interrupt the pink wire

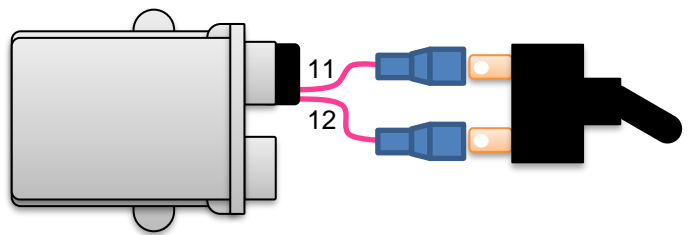

Up-fitter switch – Tape off pin 11. Connect pin 12 to the desired up-fitter switch

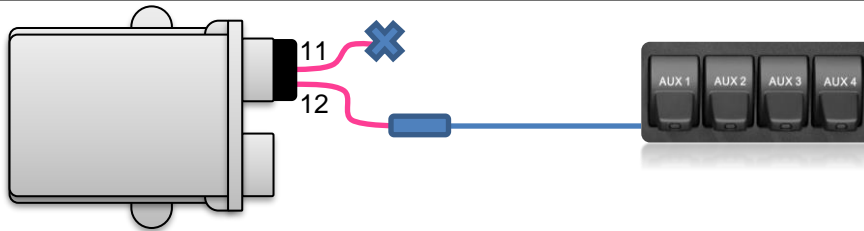

Wiring Layout

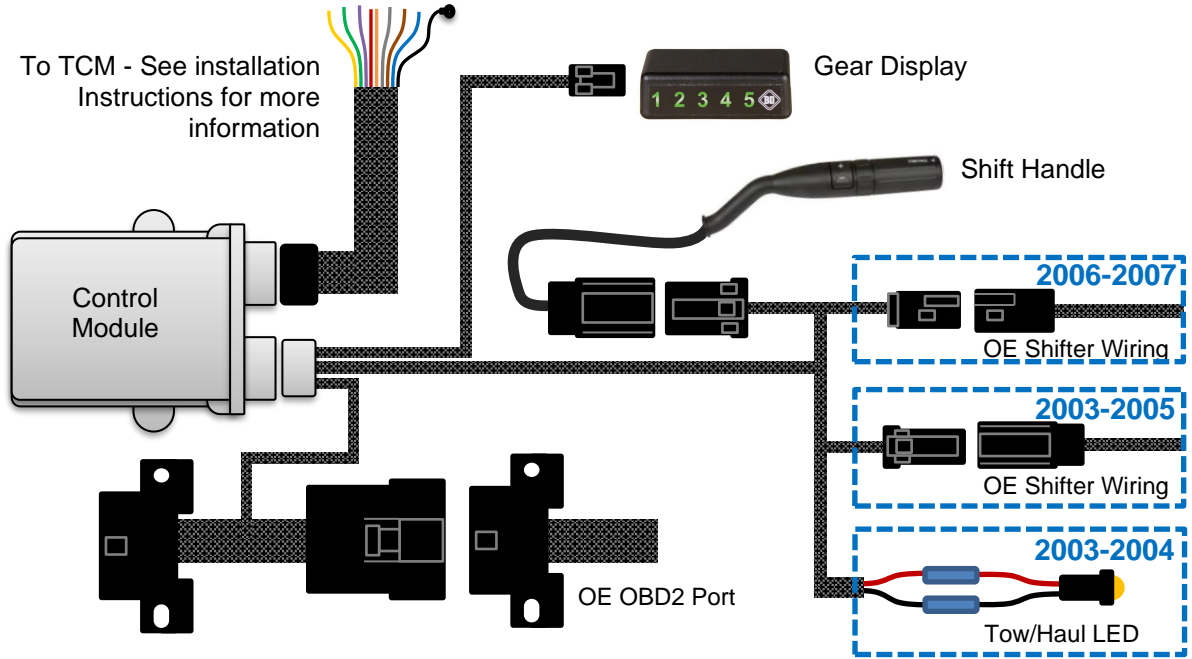

Note: One shift lever connector will be left unused.

User Adjustments

The BD Tap Shifter is designed to work out of the box with no configuration needed, but for some applications it may be desirable to adjust the shift settings. To adjust the shift pattern, turn the ignition on and put the shift lever in Park (P). Then, press and hold the up shift + button until the BD gear display illuminates (about five seconds). The number indicated is the shift strategy selected; the display will show 1+5 and 2+5 for mode 6 and 7 respectively. To change the setting, press the up shift + button to cycle through the modes available. The new setting will be stored in the modules memory. The shift strategies are listed below.

1 – Default	This is the normal mode the module is set to when it leaves the factory. Normal upshifts, downshifts, kick-downs, lockup and tow/haul functions are active. Intended for most vehicle installations. Includes modified lockup strategy for improved engine braking in 3 rd -5 th .
2 – Lower shift points 10%	Same as mode 1, but shifts occur sooner.
3 – Raise shift points 10%	Same as mode 1, but shifts occur later.
4 – Raise shift points 20%	Same as mode 1, but shifts occur later.
5 – Raise shift points 30%	Same as mode 1, but shifts occur later.
6 – Semi-manual mode	Upshifts allowed at very low speeds, no kick-downs. Stock lockup strategy.
7 – Manual/Race mode	Manual control of all shifts and torque converter lockup in ALL gears by using the tow/haul switch. This allows the truck to start in 2 nd or 3 rd gear. 4 th and 5 th gears cannot be attained until the truck reaches minimum speeds. Lockup engagement is firmer than in the other modes. Note: Using lockup in lower gears will cause harsh shifting characteristics.

Troubleshooting

Pressing the '-' button only lights up the display momentarily, then it goes back out

Yellow and blue transmission wires hooked up backwards.

TapShifter does not turn on

Open module cover to view diagnostic LEDs.

- Is the IGNITION LED lit? The module is powered from the shift lever connectors switched 12V and grounded through the OBD connector.
- Is the DRIVE LED lit? This should light up when the trucks shift lever is in D. If it does not light up in D, check the YELLOW and BLUE transmission wiring. The TapShifter will not turn on if the shift lever is not in D.
- Does the SHIFT LED light when pressing the shift lever buttons? If not, the module is not detecting the shifters + and - buttons. Check shift lever for broken or chaffed wires.
- Is the CAN LED flickering or on? This light indicates the module is receiving data from the vehicle.

No holdback in 3rd or 4th gear

Both the coast clutch and overdrive wiring must be correct to attain holdback in these gears. Verify these circuits.

The coast clutch is only commanded by the BD module when the 2->3 or 5->4 shift is done at 0% throttle or over 25% throttle to prevent a harsh engagement. Once in 3 or 4 you can press the pedal over 25% to make this engage if not already on.

Transmission fault codes or Tow/Haul lamp flashing

Transmission wiring harness connection issue.

Range sensor fault code -> Check yellow and blue wires from the TapShifter are connected the correct way around.

Solenoid circuit fault code -> Check other wires in the transmission wiring harness and the chassis ground connection.

No VVB function

Check for VGT performance codes. A stuck VGT turbo may have poor response or not close the vanes fully.

12V must be fed into pin 12 of the black connector for the module to enable the VVB function. If it has been switched, check switch function.

NOTE: The BLACK connector on the module must be kept plugged in or TCM fault codes will result. The GREY connector may be unplugged without setting codes.

Compatibility

The BD Ford 6.0 TapShifter is designed to work with all factory equipment and most aftermarket equipment.

To re-flash/reprogram any module including the ECM, TCM or FICM, it is necessary to disconnect the TapShifters OBD connection from the vehicle and connect the tuner or scan tool directly to the vehicle. Disconnecting the OBD connector will simply disable the TapShifter during the re-flash process.

Tested for compatibility with Edge Insight and Evolution CS, CTS, CTS2, H&S MiniMaxx. Not currently compatible with older Edge Evolution (first generation), GearBoxZ Electron. Others not yet tested. Compatible with tuners allowing on-the-fly power level changes.

Custom transmission tuning may set a P0741 fault code on TapShifter version 1.3 or lower – contact BD for an update file if this occurs. Some 2004 models may not function with modules version 1.3 or lower - contact BD for an update file if this occurs.

When the TapShifter is turned on it will override the shift point and lockup schedule in the TCM. Shift pressures and firmness are still determined by the TCM program.

Module Version

Current module version is V1.5 – Corrects 2004 truck compatibility, prevents TCC fault codes that may occur from custom tuning, automatic reset to prevent freezing.

All V1.0-V1.4 modules may be updated to V1.5 with a software update. Contact BD Diesel tech support for assistance.

Transmission Adaptive Learning

The 6L TapShifter may interfere with the transmissions initial adaptive learning process, particularly on earlier model trucks. A adaptive reset will be initiated when a new transmission is installed or when the PCM software is overwritten or updated (flash programming).

Do not turn on the TapShifter during the transmission adaptive learning process to allow the TCM to determine optimal shift pressures and shift quality. Using the TapShifter during this time will not allow the TCM to correctly make adjustments and may result in poor shifting characteristics. If adaptive learning problems arise, reset the learn process again and do not start using the TapShifter until the process is complete.

Note: The TapShifter can stay installed, just should not be turned on.