

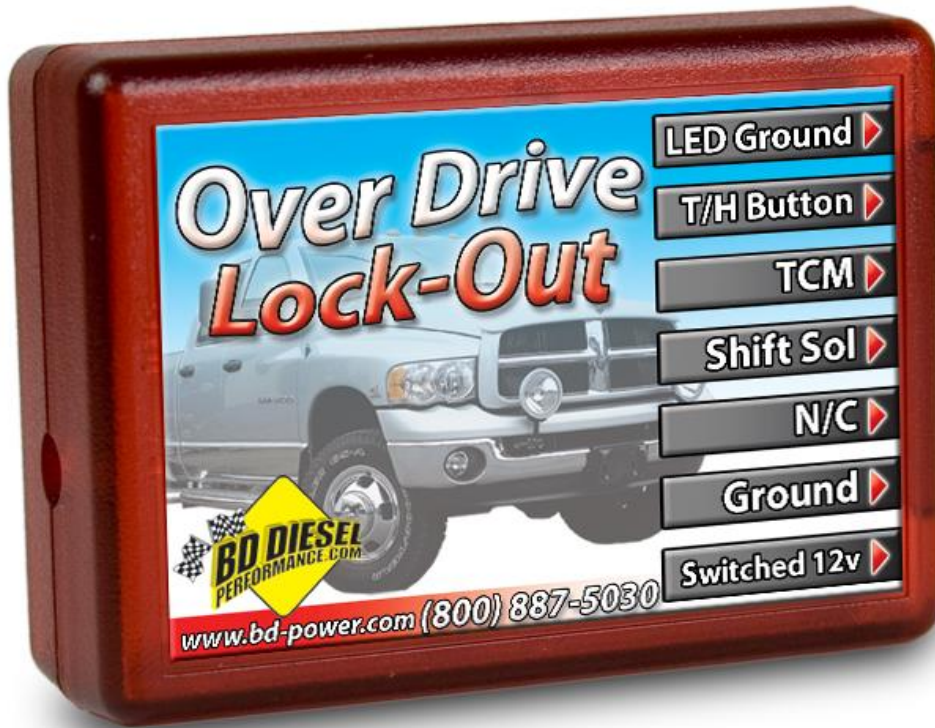

**DOWNLOAD THE LATEST
INSTALL MANUALS AT
www.bddiesel.com**



BD OverDrive Lockout
For 2005 Dodge Automatic Trucks

P/N# 1031350

PLEASE READ ALL INSTRUCTIONS BEFORE INSTALLATION.

Installation

Disconnect both batteries and safely secure the vehicle.

Locate the 50 way PCM connector on the driver's side of the engine.

This connector is closest to the firewall or the rear of the vehicle.

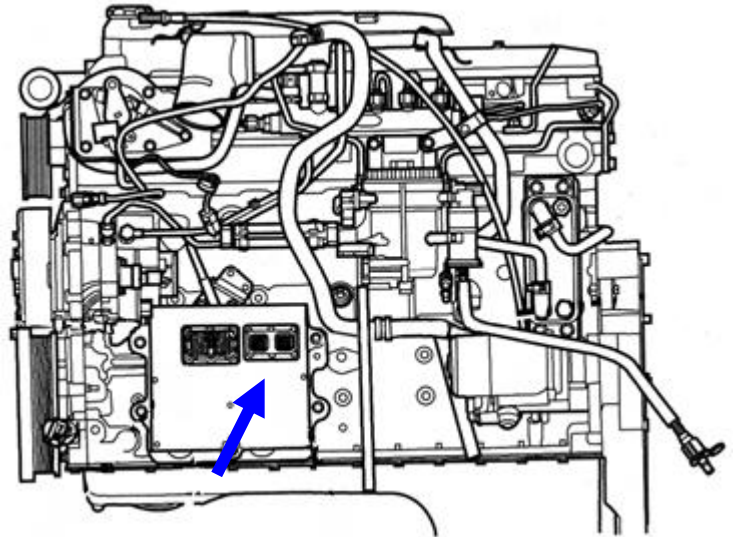

Find **pin# 15** on the 50-way PCM connector - It will be a Dark Green with a Tan tracer wire.

The diagrams shown in this manual are with the connector unplugged looking at the inside.

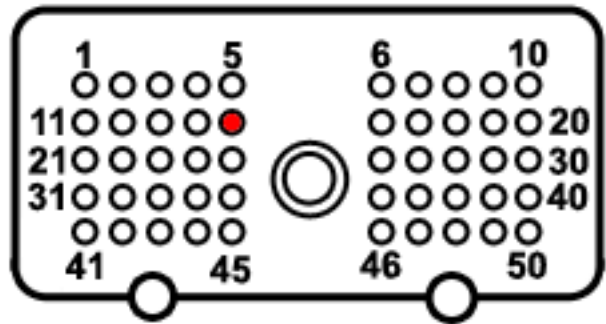

Cut this wire and attach a Posi-Lock on both sides of the cut wire. Attach the BLUE wire to the posi-lok connection closest to the PCM. Also attach the VIOLET wire to the posi-lok connection traveling towards the transmission.

Locate **pin# 13** on the 50-way PCM connector – The wire will be Dark Green in color.

Attach the Posi-Tap connection into this wire. **BE EXTRA CAREFUL THE THAT THE PIN ACTUALLY PIERCES THIS WIRE.** Connect the supplied PINK wire into the other end of the Posi-Tap.

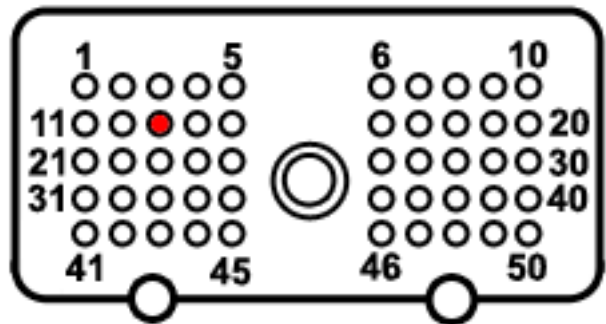

These three wires can then be routed up and through the vehicle’s firewall and into the cab. **Make sure that the wires are routed away from any heat sources or moving parts.**

Inside the cab of the vehicle, remove the kick panel to gain access underneath the steering column. Find a clean installation point to mount the OD Lockout module.

Once the module is mounted, you can connect the PINK wire that was brought in through the firewall into the “**Button**” (Push Button Tow/Haul) input.



Run the previously installed BLUE wire into the “**TCM**” (PCM 3-4 Solenoid) and the VIOLET wire into the “**Shift Sol**” (Trans. 3-4 Solenoid) input.

You will need to locate a clean ground point for the module. Underneath the steering column you can utilize a grounded mounting bolt for this purpose. Connect the grounded BLACK wire to the “Ground” input of the module.

Locate the fuse panel in the vehicle - use fuse #29. Use the supplied fuse tap and flag connector to tap onto the 12V switched source, and then route the wire to the “12V Switched” input of the module.

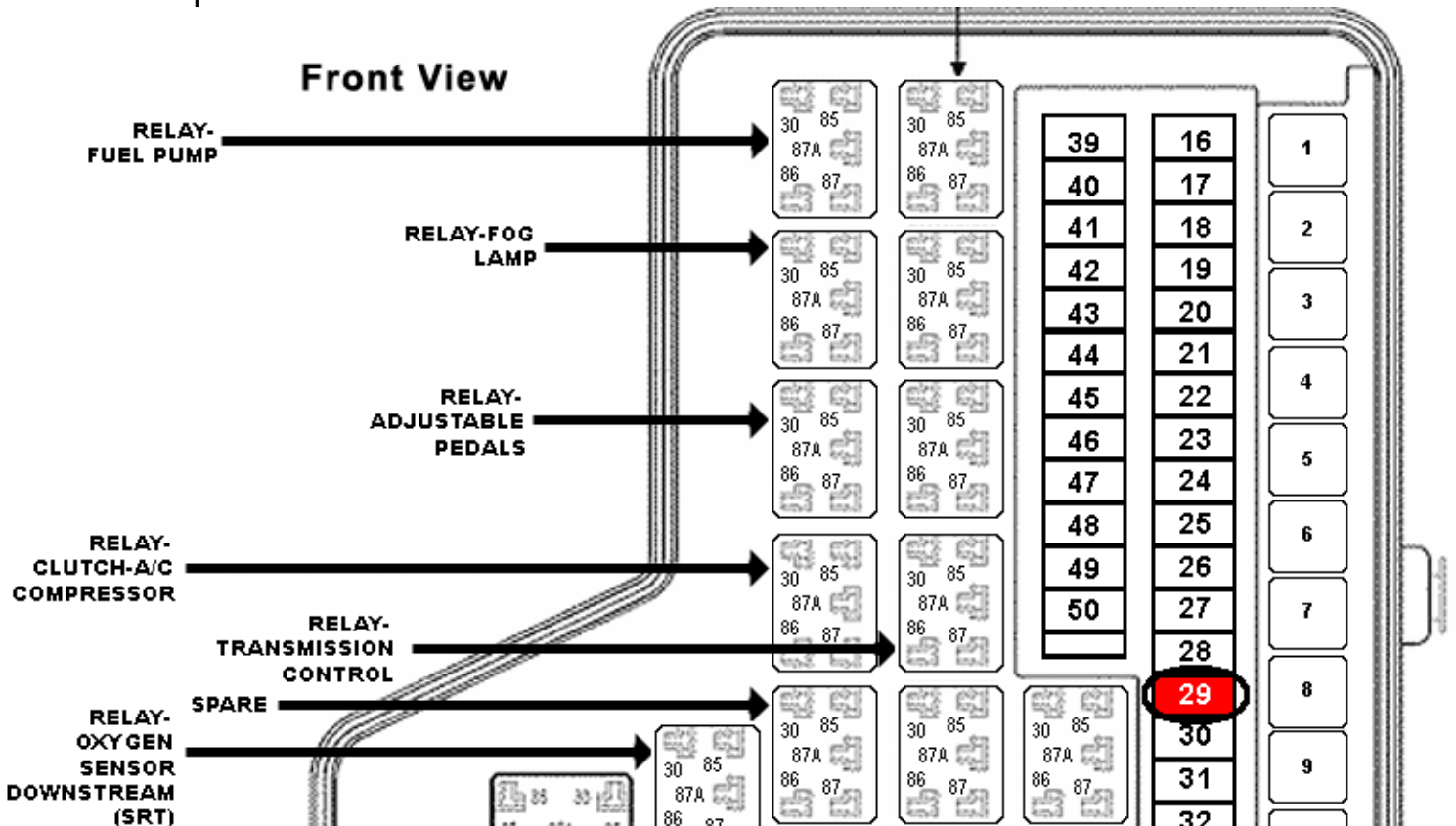

Use fuse #29 to tap into the 12V Switched source.

Locate a small flat surface on the dash that is visible to driver. Use a 0.250" drill to drill a small hole for the LED bezel. Insert the LED wires through the hole and pull them through and down till they reach the module. Snap the LED bezel into the hole securing it in place. Note that you can use crazy glue to reinforce this connection. Connect the RED wire to the "12V switched" input of the module. The BLACK wire can be routed to the "LED Ground" input of the module.

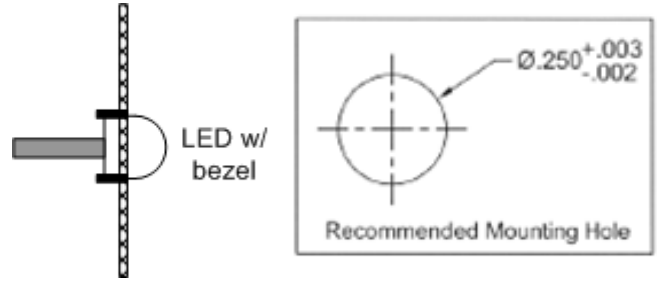

Wiring Diagram

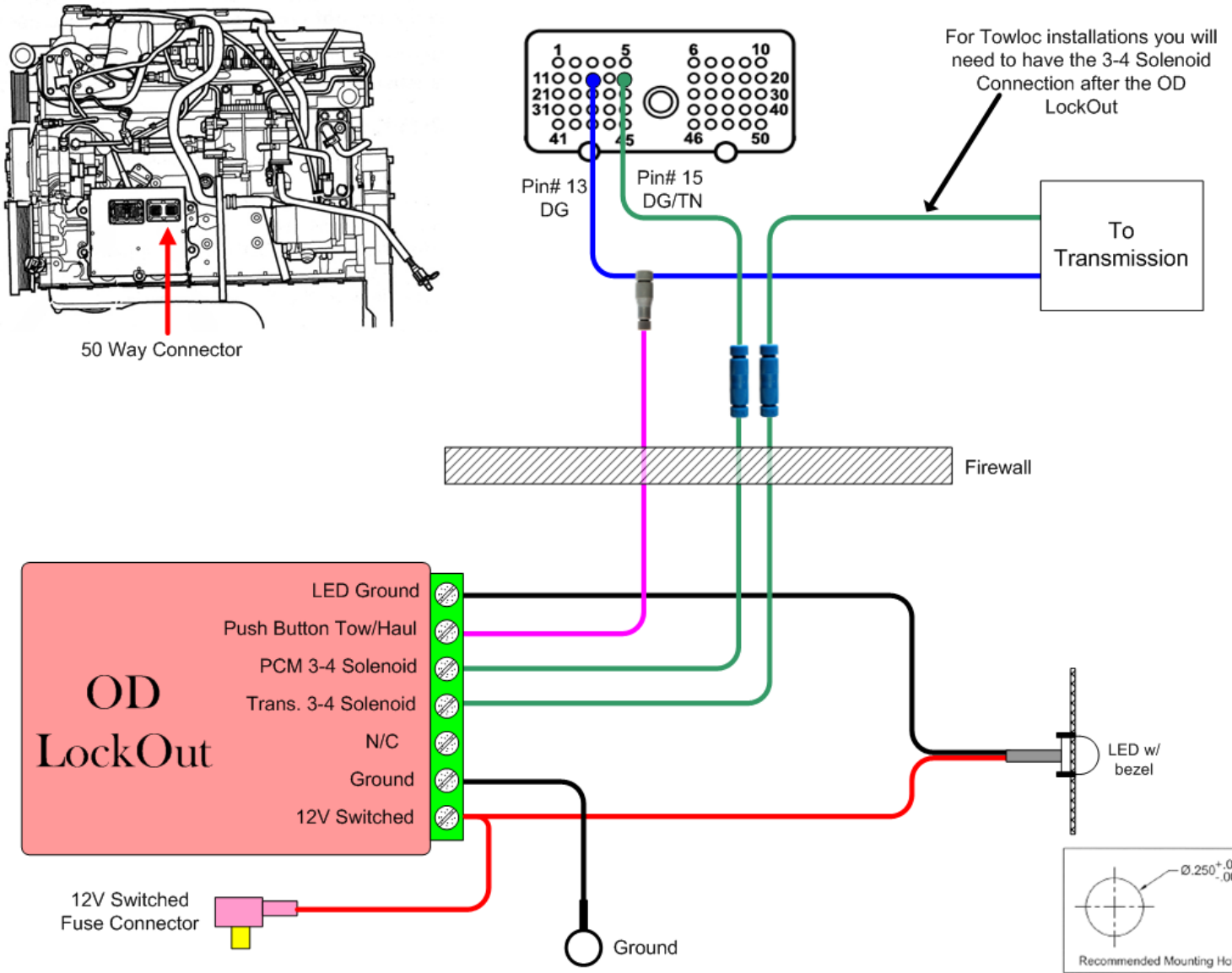

Note: When using OD Lockout unit with a BD TowLoc, the 3-4 solenoid connection must be made *after* the OD LockOut connection.

Operation

The BD OverDrive Lockout uses the factory Tow Haul (TH) button for activation. Pressing the TH button twice in rapid succession will toggle the module on and off.

When the module is active, the dash mounted LED will light up to show overdrive is disabled. When the module is active, the transmission is kept from shifting into 4th gear or will downshift from 4th to 3rd.

Note: Pressing the button twice quickly to enable the module should turn tow haul mode on and back off. If pressed too quickly tow haul mode may stay on, in which case a single press will correct this.