

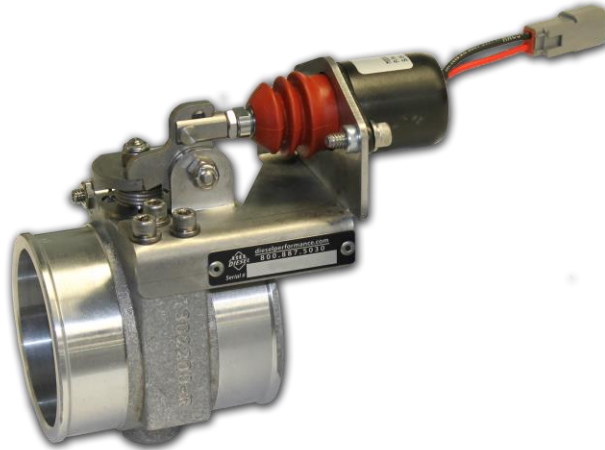

**DOWNLOAD COLOUR
INSTALL MANUALS AT
www.bddiesel.com**



**2011-2015 GM 6.6L (LML) Duramax
Positive Air Shutoff
2.5" CAC TUBES**

P/N#	1036713
P/N#	1036713-M









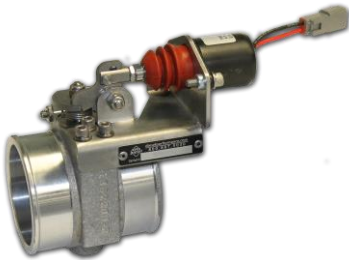

PLEASE READ ALL INSTRUCTIONS BEFORE INSTALLATION

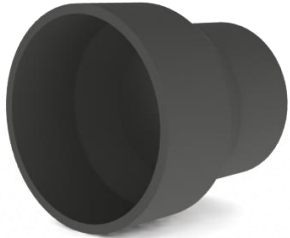

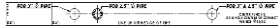

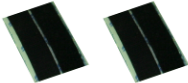

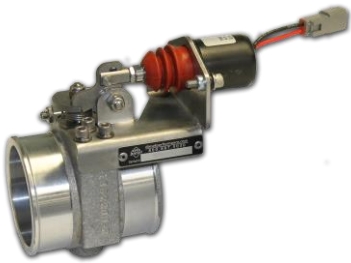

An Information decal has been provided in this kit. This may allow safety personal and inspector's to quickly identify that your vehicle is equipped with a BD Positive Air Shut Down unit. Install this decal in a visible location on the inside glass of the vehicle.

KIT CONTENTS:

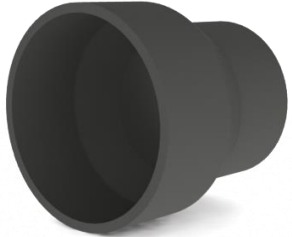
Please check to make sure that you have all the parts listed in this kit **before** you start the disassembly your truck.

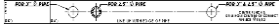
1036713 Kit Contents			
1302300-A	1302276	1302242-A	1302272
			
<i>Air Shutoff Valve</i>	<i>Elbow Silicone Boot</i>	<i>Wiring Harness</i>	<i>2.5"-3 1/4" Silicone Boot</i>
Qty: 1	Qty: 1	Qty: 1	Qty: 1
1302281	1302282	1407030	1405208
			
<i>2.5" PAS Bead Ring</i>	<i>PAS Drill Template</i>	<i>0350 Clamps</i>	<i>2.59-2.94" Clamps</i>
Qty: 1	Qty: 1	Qty: 2	Qty: 2
FT-10910-03116	1301381	1306741	1302285
			
<i>Velcro strips</i>	<i>Heat Shrink</i>	<i>PAS Module</i>	<i>Solder</i>
Qty: 2 pcs	Qty: 3"	Qty: 1	Qty: 5"

1036713-M Kit Contents			
1302300-A	1302276	1302249-A	1302272
			
<i>Air Shutoff Valve</i>	<i>Elbow Silicone Boot</i>	<i>Wiring Harness</i>	<i>2.5"-3 1/4" Silicone Boot</i>
Qty: 1	Qty: 1	Qty: 1	Qty: 1
1302281	1302282	1407030	1405208
			
<i>2.5" PAS Bead Ring</i>	<i>PAS Drill Template</i>	<i>0350 Clamps</i>	<i>2.59-2.94" Clamps</i>
Qty: 1	Qty: 1	Qty: 2	Qty: 2

WELCOME

Thank you for purchasing a BD positive air shutoff. This manual is divided into different areas to assist you with your installation and operation of your positive air shutoff.

This product is a safety product and should be tested often.

Installation should occur on a vehicle properly secured to prevent rolling.

TABLE OF CONTENTS

REQUIRED TOOLS.....	4
MAINTENANCE.....	5
INSTALLATION with OVER SPEED ELECTRONICS (1036713).....	5
(2011 – 2014)AUX HVAC-IGN #45 (10AMP).....	14
(2015) MISC-IGN #39 (15AMP).....	15
INSTALLATION without OVER SPEED ELECTRONICS (1036713-M).....	17
(2011-2014) AUX HVAC-IGN #45 (10AMP).....	26
(2015) MISC-IGN #39 (15AMP).....	27
WIRING DIAGRAM with OVER SPEED ELECTRONICS (1036713).....	29
WIRING DIAGRAM without OVER SPEED ELECTRONICS (1036713-M).....	30
BEAD RING AND DRILL JIG INSTALLATION.....	31
RESETTING THE VALVE.....	32
SETUP, TESTING AND VERIFICATION with OVER SPEED ELECTRONICS.....	33
Automatic Mode (Pre Configured RPM).....	33
Manual Mode (User Configured RPM).....	35
TESTING FLOW CHART with OVER SPEED ELECTRONICS.....	38
TESTING FLOW CHART without OVER SPEED ELECTRONICS.....	39
PCB LED Operation.....	40

REQUIRED TOOLS

- Frequency/Voltmeter (Suggested)
- Drill
- 1/8", 11/32" Drill Bit
- 1/2" Unibit
- Electrical Tape
- Soldering Iron
- Needle Nose Pliers
- Air or Manual Ratchet
- 7/16", 1/2" Sockets
- Wire Strippers
- Heat Gun
- Band Saw or reciprocating saw or cutoff wheel.

MAINTENANCE

The only maintenance required is to test the valve operation at regular intervals. Please see the testing section later in the manual for the correct procedure.

INSTALLATION with OVER SPEED ELECTRONICS (1036713)



VEHICLE SHOULD BE SAFELY SECURED BEFORE INSTALLATION.

1. Block the wheels of the vehicle to prevent the vehicle from rolling.

Open the hood.

2. You will need to remove the driver's side Charge Air Cooler (CAC) tube. Loosen both clamps and disconnect from the turbo inlet connection, then disconnect from the CAC and maneuver it from the vehicle.

3. With the driver's side CAC tube removed, lay it flat on a work bench.

First identify the turbo inlet side and the CAC outlet side of the tube.



4. You will need to make one cut 1 1/2" from the tangent edge of the pipes second bend from the turbo inlet side.

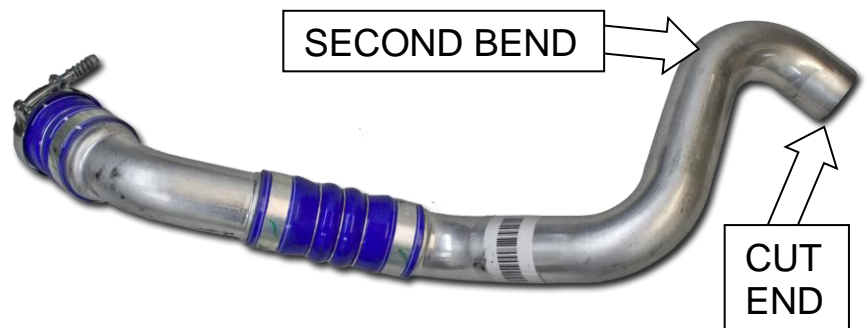
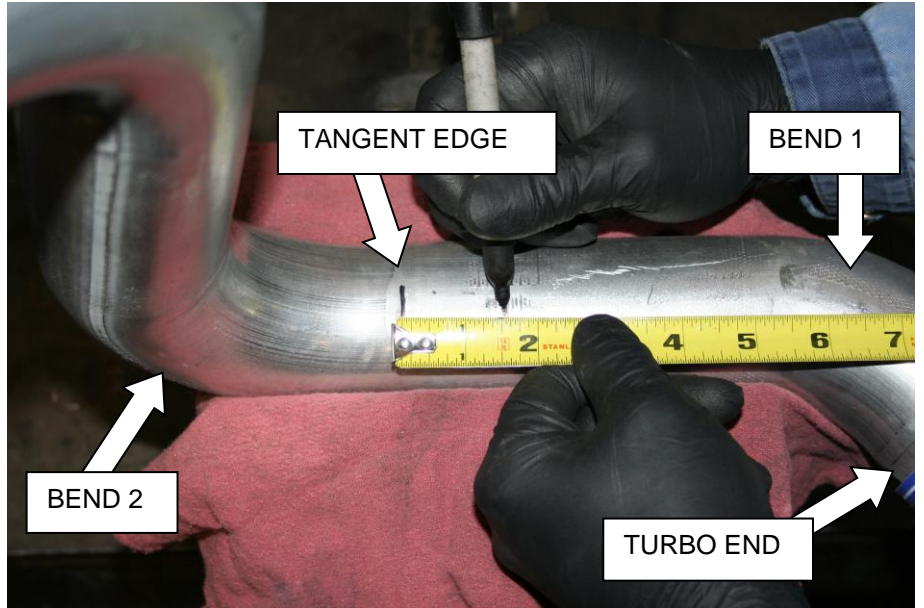

5. With the pipe cut, you will now need to drill a couple of holes to secure the boot bead on both ends of the pipe.

6. Firstly, remove the backing from drill template sticker and wrap around pipe. The edge of the sticker should line up with the edge of the pipe.

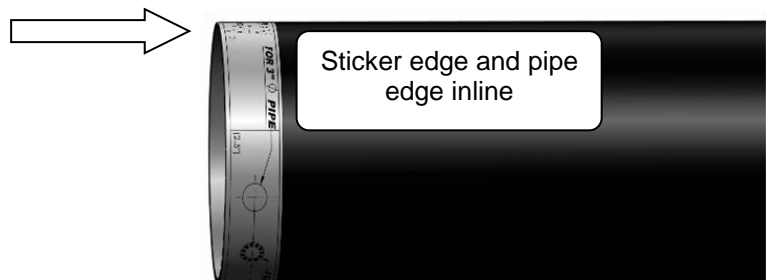
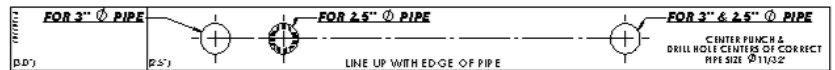

YOU WILL USE THE 2.5" TEMPLATE MARKS

For the 2.5" pipe the sticker should wrap perfectly around the pipe, the start of the sticker should meet the end of the sticker.

7. With the sticker in place use a center punch and then use a $\text{\O}1/8$ " drill bit and drill a hole in the center of the holes marked "**For 2.5"Ø**".

There will be two holes and they should be perfectly 180° inline with each other through the pipe.

DO NOT DRILL COMPLETELY THROUGH THE PIPE AND OUT THE OTHER END. YOU WILL NEED TO DRILL ONE SIDE THEN ROTATE, AND THEN DRILL THE OTHER SIDE.

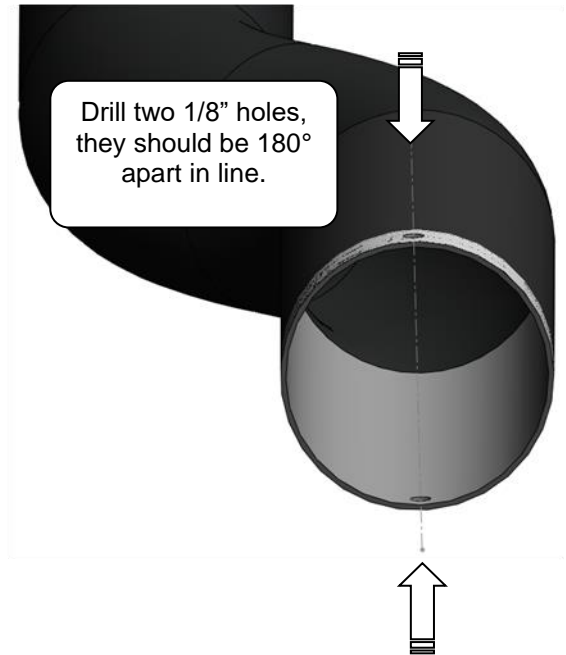

8. Once the pilot holes are drilled you will need to drill an $\text{\O}11/32$ " hole through the pilot holes.

You can now remove the sticker.

You must deburr the inside of the drilled holes.

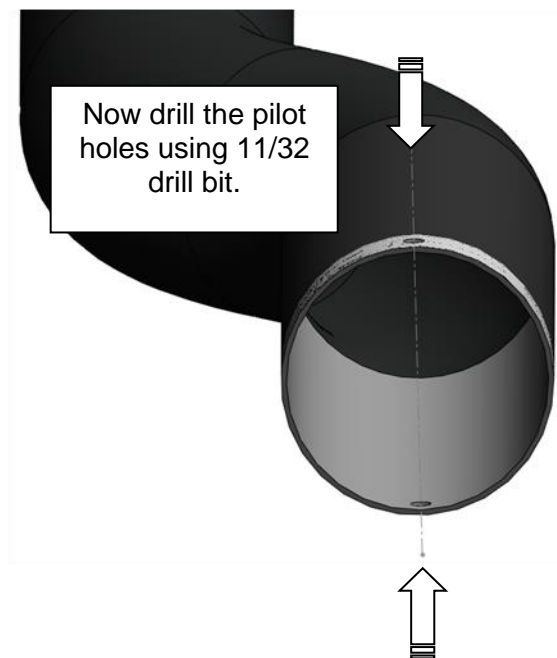

9. Once the holes are drilled, install the ring bead around the pipe. Lock each end of the ring bead into each hole.

You can use a needle nose plier to tweak or adjust the ring fit slightly.

Be careful not to bend the ring bead too much as you will weaken it.

Note the ring bead does not have to be perfectly tight or snug around the pipe, as we will be installing a silicone boot over top of it.

With the ring bead in place, you should not be able to pull the ring bead off axially from the tube.



10. Slide one 0300 clamp onto the pipe then install the step boot (#1302272) onto the pipe over the bead ring.

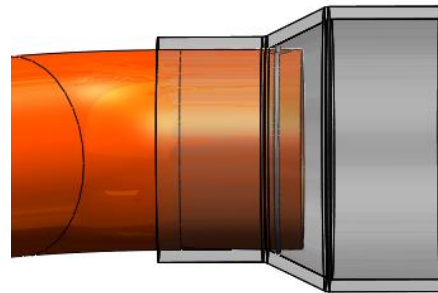

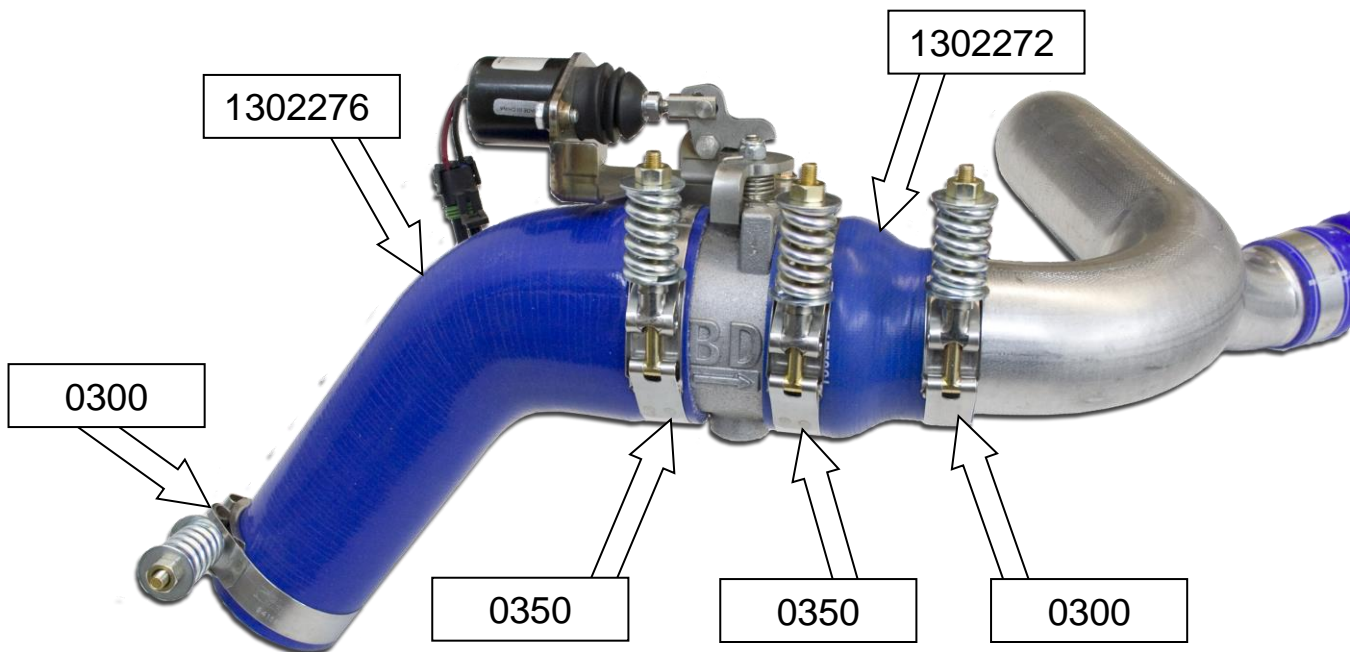

11. Once the boot and clamp are in place you can install the valve ensuring the flow orientation arrow on the side of the casting points towards the CAC. Then install the elbow boot with the supplied clamps. Leave all clamps loose until proper in vehicle fitment can be determined.

12. Install PAS tube assembly into the vehicle CAC side first. Note that you will need to rotate the tubes you achieve perfect alignment. Once you are happy with fit and the PAS unit will not contact any other components or vibrations. Tighten all spring clamps until the spring is spring bound.

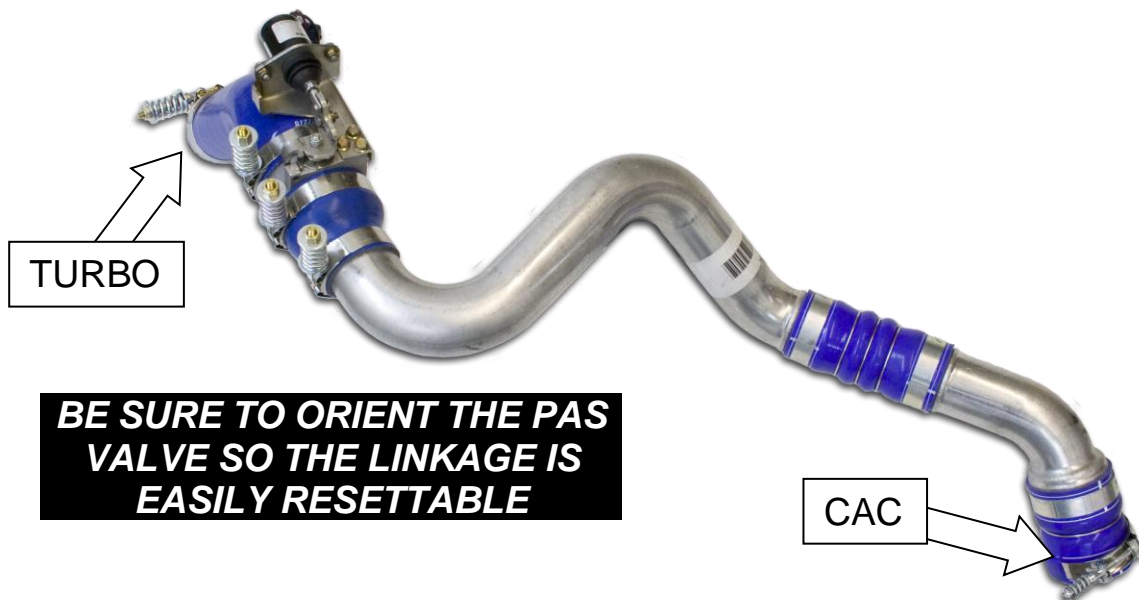

13. Lay out supplied wiring harness over top of the engine.



14. You will then need to route the switch through the firewall on the driver's side (note you will need to remove the switch from the harness to accomplish this). See wiring diagram on page 29

Choose a highly visible location for the switch and mount it to the dash.



15. Using a 1/8" drill, drill a pilot hole in the location you have selected for the switch to be mounted.

16. Finally using a 1/2" UNIBIT drill bit, drill an exact 1/2" round hole.

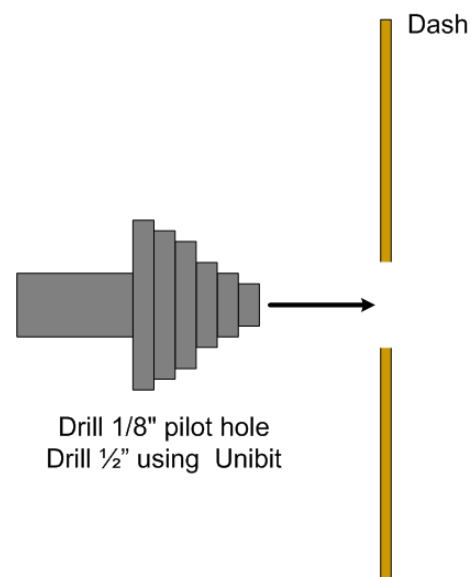

17. Once you have the mounting hole drilled, insert the switch from the backside.

Reinstall the correct wires to the correct switch terminals.

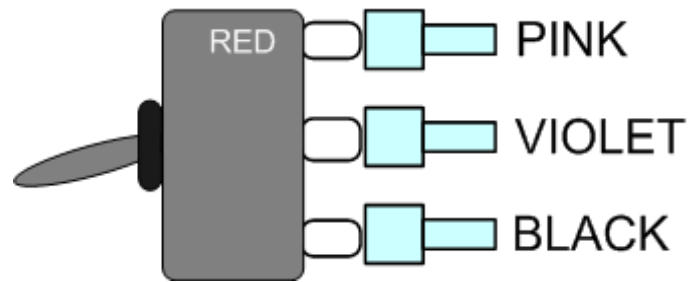

18. Mount the switch so that the groove on the thread boss is facing down.

Adjust the HEX washer/nut so that the switch threads do not protrude an unsightly amount.

Switch install with decal

Apply the supplied decal to the dash and tighten the round plastic nut.

Switch install with Guard

Install the switch guard onto the switch by aligning the tab with the groove on the thread boss.

Then tighten on the round plastic nut and apply the decal to the switch guard.

Switch install with Decal

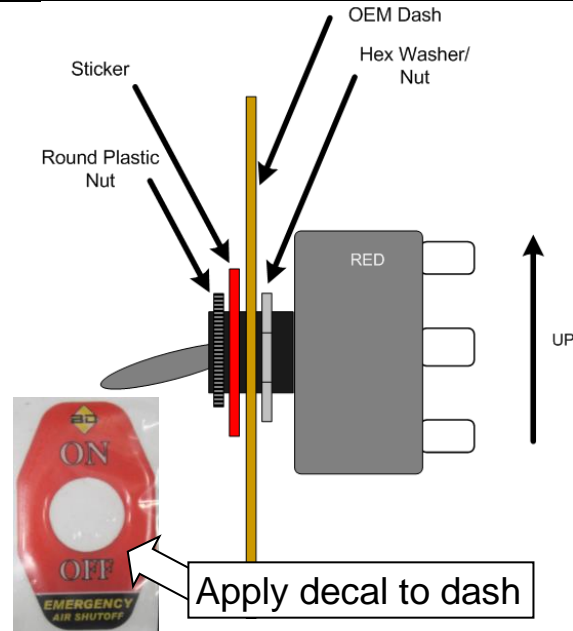

Switch Install with Guard

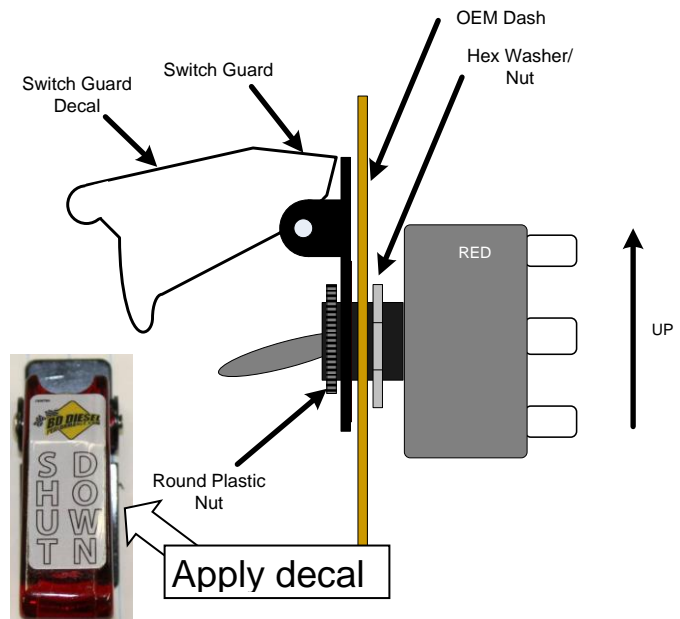

19. Now underneath the hood, locate and connect the weather pack connector on the wiring harness to the solenoid on the PAS valve. See page 29 for more info.

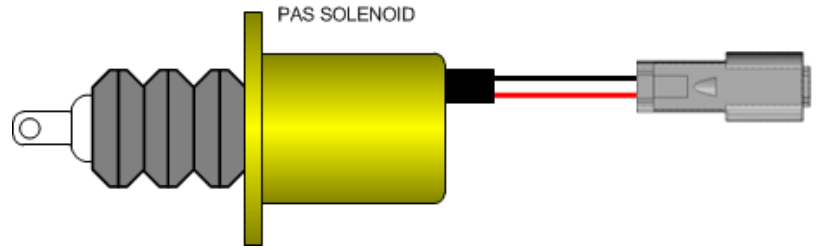

Connector Part Information

Harness:
 Engine Chassis
 OEM: 12603597
 Service: 13574948
 Description: 73-Way F
 MX123 34566 Series (GY)

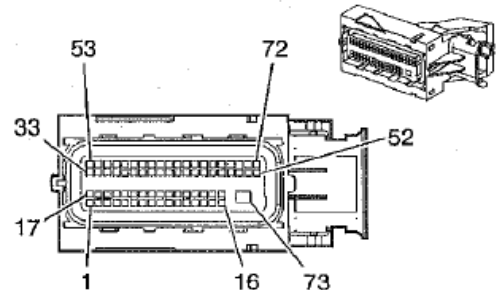

20. You will now need to locate the CRANKSHAFT SENSOR Wire.

Locate the ECM Connector #3.

21. This connector will have 73 pins, locate pin 61 and follow the direction in step 22.

Pin	Wire Color	Circuit No.	Function
54	0.5 L-GN/BK	5746	Exhaust Gas Recirculation Valve Motor Low Signal
55	0.5 OG/BK	5764	Exhaust Gas Recirculation Valve Motor High Signal
56	0.8 BN	582	Throttle Actuator Control Close
57	0.8 YE	581	Throttle Actuator Control Open
58	0.5 OG/BK	3656	EGR Cooler Bypass Motor Close Control (LML)
59	0.5 L-GN	3655	EGR Cooler Bypass Motor Open Control (LML)
60	0.5 GY/BK	6272	Low Reference
61	0.5 WH/BK	6271	CKP Sensor Signal
62	0.5 D-GN	485	Throttle Position Sensor

22. Being that the RPM signal is critical you will need to solder the connection.

Using wire strippers create a 1" window/gap in insulation of the wire.

Then strip about 1" of insulation of the RPM signal wire of the BLUE wire from the PAS wiring harness.

Wrap the copper wire around the factory RPM signal wire and solder this connection.

Then use electrical tape to wrap this connection so that it is water tight.

You can also cut the factory crank signal wire and use heat shrink tubing if you would like.

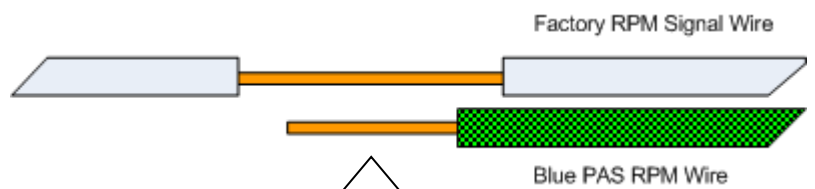

Solder the connection and then wrap and seal with electrical tape

23. Run the BLACK and RED wires on the harness to the battery and connect to respective power and ground connections.

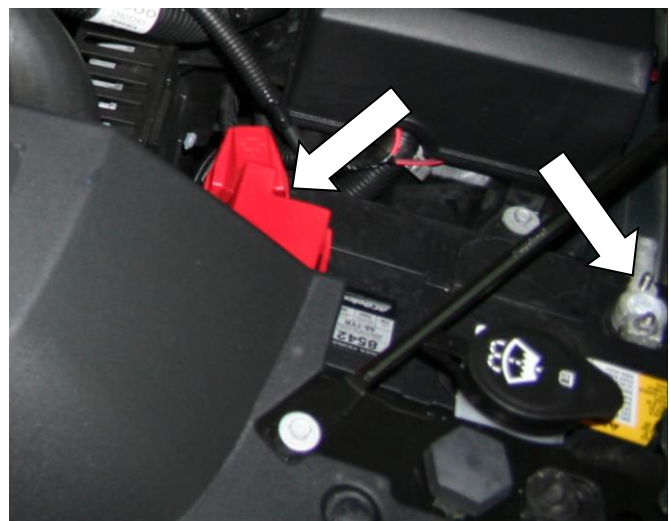

24. For the last connection you will need to locate ignition power. This will power the automatic over speed control box LED switch. Note that the unit can still be activated manually with the switch at any time.

Locate the battery junction box at the driver's side mid of the engine compartment.

Open the junction box and locate the appropriate fused ignition power circuit (see table below). Install fuse tapper on to fuse, reinstall fuse. Connect yellow lead wire with flag connector to this new connection. Route wire out of the box and close lid.

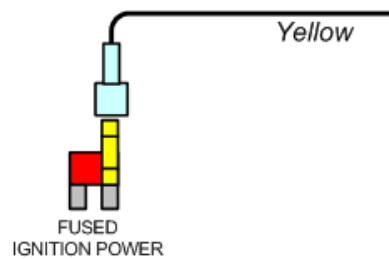
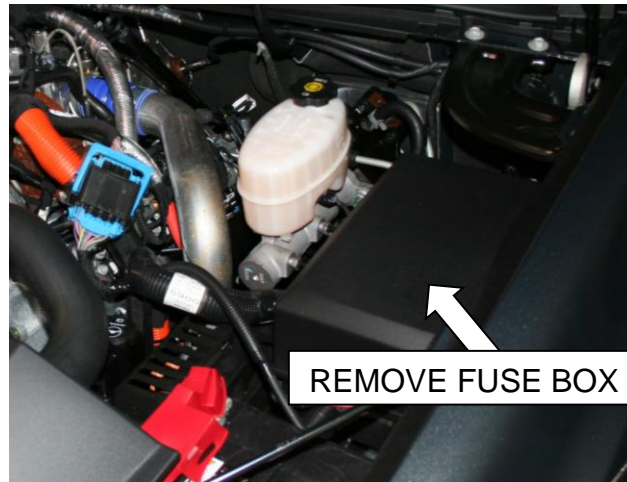

(2011 – 2014)AUX HVAC-IGN #45 (10AMP)

Pin	Wire Color	Circuit No.	Function
39	RDO Fuse	15A	Digital Radio Receiver (U2K), Radio, Rear Seat Audio (RSA) Control (UK6), Chime Module (UL5)
40	MISC IGN Fuse	10A	Auxiliary Body Control Module (XBCM) (EXP), Stop Lamp Switch, Transfer Case Shift Control Module (NQF or NQH), Trailer Brake Control Module (JL1)
41	L/GATE RELSE Fuse	15A	Not Used
42	AIRBAG BATT Fuse	15A	Inflatable Restraint Passenger Presence System (PPS) Module, Inflatable Restraint Sensing and Diagnostic Module (SDM), Inflatable Restraint Vehicle Roll-over Sensor (ASF)
43	IPC Fuse	10A	Body Control Module (BCM), Instrument Panel Cluster (IPC)
44	EXP/PTO Fuse	15A	Auxiliary Body Control Module (XBCM) (EXP) Power Take Off Relay (PTO)
45	AUX HVAC-IGN Fuse	10A	Instrument Panel Cluster (IPC), Inside Rearview Mirror (ISRM), Heated Steering Wheel Module Control (KA9)
46	CHMSL Fuse	15A	Center High Mounted Stop Lamp (CHMSL)
47	REAR DEFOG Fuse	30A	Rear Window Defogger Grid

DIESEL

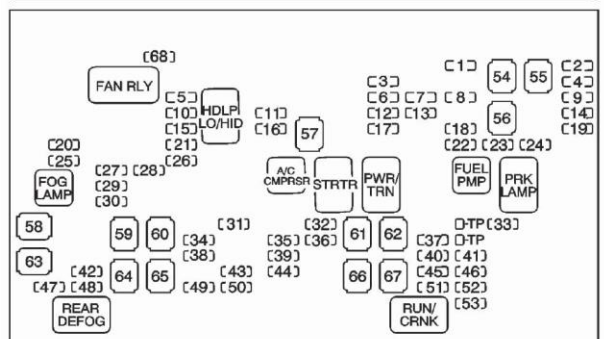

MINI FUSES

- MINI-FUSIBLES**
- 1 – ESC/ALC EXH (30A)
 - 2 – TRLR STOP LT (10A)
 - 3 – ENG (15A)
 - 4 – TRLR STOP RT (10A)
 - 5 – FRT WASH (15A)
 - 6 – FUEL HTR (15A)
 - 7 – TCM-BATT (15A)
 - 8 – ABS 2 (25A)
 - 9 – TRLR BCK/UP (10A)
 - 10 – LO HDLP-LT (20A)
 - 11 – ECM-BATT (10A)
 - 12 – DSL ECM (30A)
 - 13 – TRNS IGN 1 (15A)
 - 14 – VEH BCK/UP (10A)
 - 15 – LO HDLP-RT (20A)
 - 16 – A/C CMPSRSR (10A)
 - 17 – EMC/THROT CONT (15A)
 - 18 – FUEL PUMP (25A)
 - 19 – ITBC (15A)
 - 20 – HDLP WASH (20A)
 - 21 – REAR WASH (15A)
 - 22 – TRLR PRK (15A)
 - 23 – LT PRK (15A)
 - 24 – RT PRK (15A)
 - 25 – FOG LAMP (15A)
 - 26 – HORN (15A)
 - 27 – HI HDLP (15A)
 - 28 – DRL (15A)
 - 29 – HI HDLP-LT (10A)
 - 30 – DRL 2 (15A)
 - 31 – S/ROOF (30A)
 - 32 – DLIS (2A)
 - 33 – WPR (25A)
 - 34 – SEO B2 (30A)
 - 35 – EAP (15A)
 - 36 – HVAC BATT (10A)
 - 37 – AIRBAG IGN (10A)
 - 38 – AMP (30A)
 - 39 – RDO (15A)
 - 40 – MISC IGN (10A)
 - 41 – L/GATE RELSE (15A)
 - 42 – AIRBAG BATT (15A)
 - 43 – IPC (10A)
 - 44 – EXP/PTO (15A)
 - 45 – AUX HVAC-IGN (10A)
 - 46 – CHMSL (15A)
 - 47 – REAR DEFOG (30A)
 - 48 – HTD MIR (15A)
 - 49 – SEO B1 (15A)
 - 50 – LTR (20A)
 - 51 – SEO/ALC (10A)
 - 52 – HVAC-IGN (10A)
 - 53 – ECM-IGN (15A)
 - 54 – ALC/COMP (40A)
 - 55 – HEAVY DUTY ABS (60A)
 - 56 – ABS-1 (40A)
 - 57 – STRTR (40A)
 - 58 – STUJ-2 (30A)
 - 59 – LBEC1 (60A)
 - 60 – ELEC RUN BOARD (30A)
 - 61 – WSW/HTR (60A)
 - 62 – TREC (30A)
 - 63 – STUJ-1 (40A)
 - 64 – MBEC1 (60A)
 - 65 – HVAC BLWR (40A)
 - 66 – LGM (30A)
 - 67 – LBEC2 (60A)
 - 68 – FAN (10A)

J-CASE FUSES

- J-CASE FUSIBLES**
- 54 – ALC/COMP (40A)
 - 55 – HEAVY DUTY ABS (60A)
 - 56 – ABS-1 (40A)
 - 57 – STRTR (40A)
 - 58 – STUJ-2 (30A)
 - 59 – LBEC1 (60A)
 - 60 – ELEC RUN BOARD (30A)
 - 61 – WSW/HTR (60A)
 - 62 – TREC (30A)
 - 63 – STUJ-1 (40A)
 - 64 – MBEC1 (60A)
 - 65 – HVAC BLWR (40A)
 - 66 – LGM (30A)
 - 67 – LBEC2 (60A)

(2015) MISC-IGN #39 (15AMP)

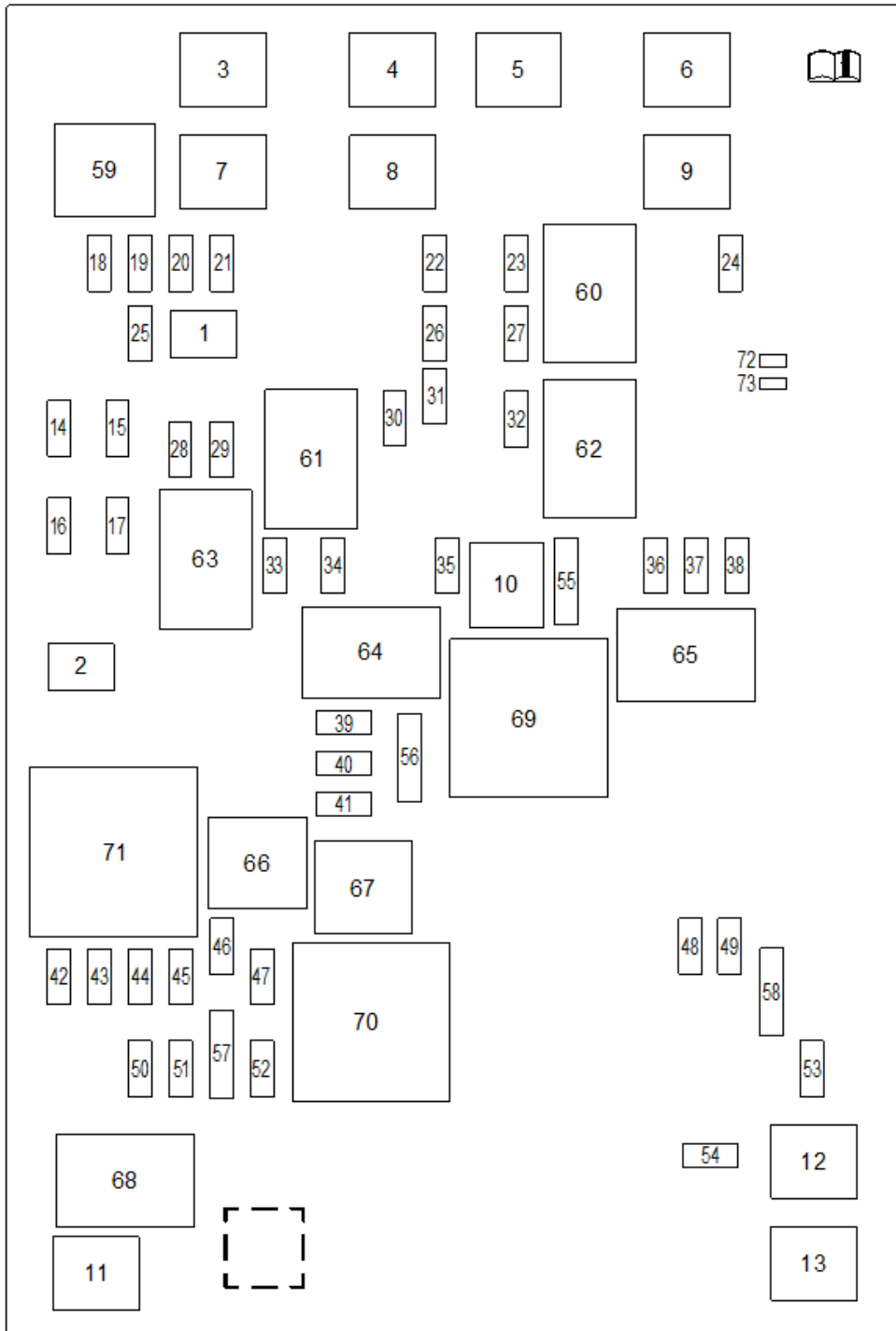

- 7. ELEC PRK BRK (40A)
- 8. I/P BEC 2 (80A)
- 9. MSB DRVR (40A)
- 10. REAR DEFOG (30A)
- 11. STRTR (40A)
- 12. COOL FAN 1 (40A)
- 13. COOL FAN 2 (40A)

MINI FUSES 2 PIN

- 14. TRLR STOP TRN LT (10A)
- 15. TRLR PRK LAMP (20A)
- 16. REV LAMP (10A)
- 17. TRLR STOP TRN RT (10A)

MICRO FUSES 2 PIN

- 18. FUEL PUMP (20A)
- 19. ICCM (10A)
- 20. ESC ELC EXH (30A)
- 21. FPPM (30A)
- 22. UPFTR SW1 (5A)
- 23. UPFTR 2 (30A)
- 24. FRT/WPR (25A)
- 25. ABS VLV (25A)
- 26. UPFTR SW2 (5A)
- 27. UPFTR SW3 (5A)
- 28. PR K LAMP RT (15A)
- 29. PR K LAMP LT (15A)
- 30. UPFTR 3 (30A)
- 31. UPFTR SW4 (5A)
- 32. UPFTR 4 (30A)
- 33. BCK UP LAMP (10A)
- 34. ECM IGN (15A)
- 35. A/C CLTCH (10A)
- 36. HTD MIR (15A)
- 37. UPFTR 1 (30A)
- 38. CHMSL (10A)
- 39. MISC IGN (15A)
- 40. TRANS IGN (15A)
- 41. FUEL PUMP 2 (20A)
- 42. COOL FAN CLTCH (10A)
- 43. ENG (15A)
- 44. INJ A ODD (20A)
- 45. INJ B EVEN (20A)
- 46. O2 SNSR B (15A)
- 47. THROT CONT (15A)
- 48. HORN (15A)
- 49. FOG LAMP (15A)
- 50. O2 SNSR A (15A)
- 51. ECM (30A)
- 52. INT HTR (10A)
- 53. ACCY PWR MDL/TPIM PUMP (10A)
- 54. FRT WASH (15A)

MICRO FUSES 3 PIN

- 55. A/C CMPSR MDL/BATT RVC (5A/5A)
- 56. A/C CMPSR MDL/BATT PCK (10A/10A)
- 57. TCM / ECM (15A/15A)
- 58. HDLP RT / LT (10A/10A)

MICRO RELAYS

- 59. FUEL PUMP
- 60. UPFTR 2
- 61. UPFTR 2
- 62. UPFTR 2
- 63. TRLR PRK LAMPS
- 64. RUN/CRNK
- 65. UPFTR 1
- 66. FUEL PUMP 2
- 67. A/C CNTRL
- 68. STRTR

25. Mount the electronic control unit on top of the junction/fuse box. Be sure to clean the mounting surface with alcohol before applying Velcro.

Connect the wiring harness to the electronic control unit.

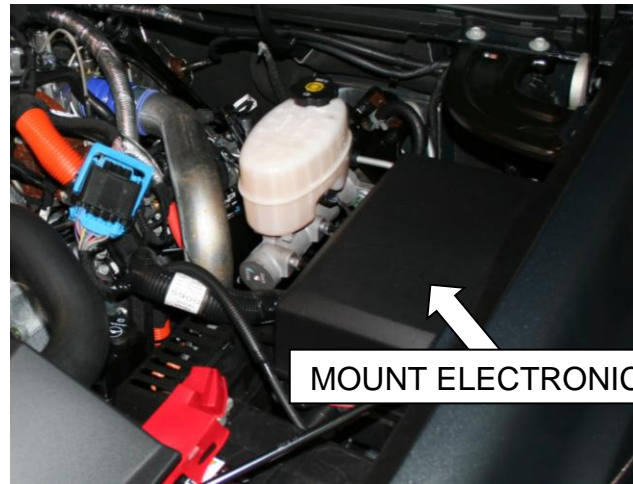

26. Double check all wiring connections and ensure wires are routed away from any heat sources and moving parts. And continue to the Setup, Testing and Verification with Over Speed Electronics section in this manual.

INSTALLATION without OVER SPEED ELECTRONICS (1036713-M)

VEHICLE SHOULD BE SAFELY SECURED BEFORE INSTALLATION.

1. Block the wheels of the vehicle to prevent the vehicle from rolling.

Open the hood.

2. You will need to remove the driver's side Charge Air Cooler (CAC) tube. Loosen both clamps and disconnect from the turbo inlet connection, then disconnect from the CAC and maneuver it from the vehicle.
3. With the driver's side CAC tube removed, lay it flat on a work bench.

First identify the turbo inlet side and the CAC outlet side of the tube.



4. You will need to make one cut 1 1/2" from the tangent edge of the pipes second bend from the turbo inlet side.

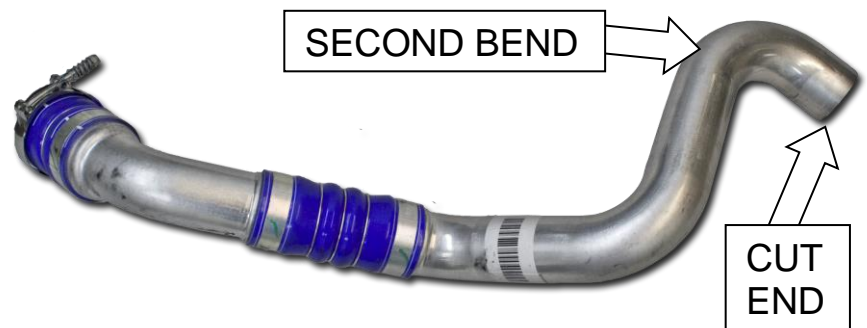
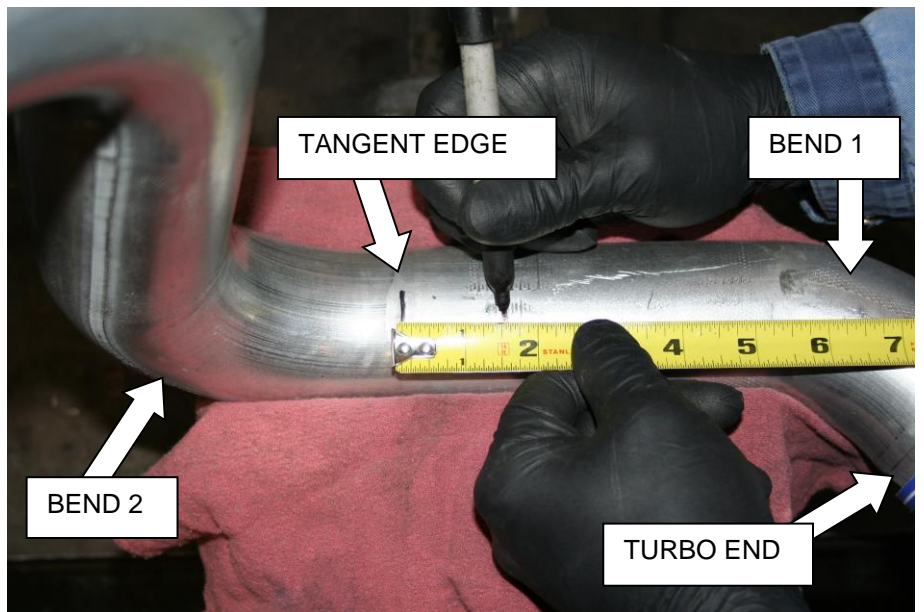

5. With the pipe cut, you will now need to drill a couple of holes to secure the boot bead on both ends of the pipe.

6. Firstly, remove the backing from drill jig sticker and wrap around pipe. The edge of the sticker should line up with the edge of the pipe.

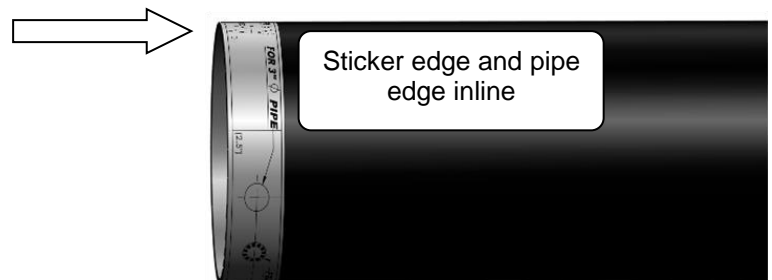
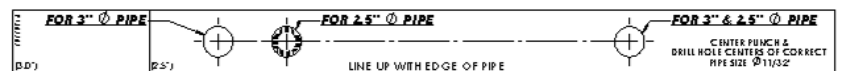

YOU WILL USE THE 2.5" TEMPLATE MARKS

7. For the 2.5" pipe the sticker should wrap perfectly around the pipe, the start of the sticker should meet the end of the sticker.

With the sticker in place use a center punch and then use a $\text{\O}1/8$ " drill bit and drill a hole in the center of the holes marked "**For 2.5"Ø**".

There will be two holes and they should be perfectly 180° inline with each other through the pipe.

DO NOT DRILL COMPLETELY THROUGH THE PIPE AND OUT THE OTHER END. YOU WILL NEED TO DRILL ONE SIDE THEN ROTATE, AND THEN DRILL THE OTHER SIDE.

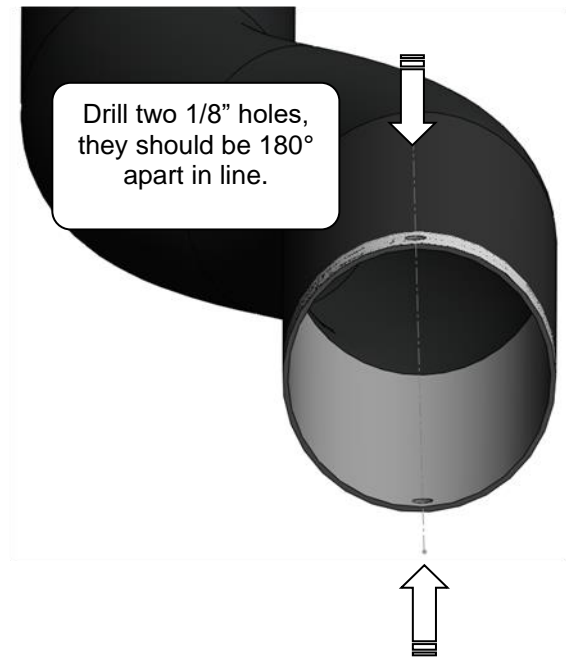

8. Once the pilot holes are drilled you will need to drill an $\text{Ø}11/32$ " hole through the pilot holes.

You can now remove the sticker.

You must deburr the inside of the drilled holes.

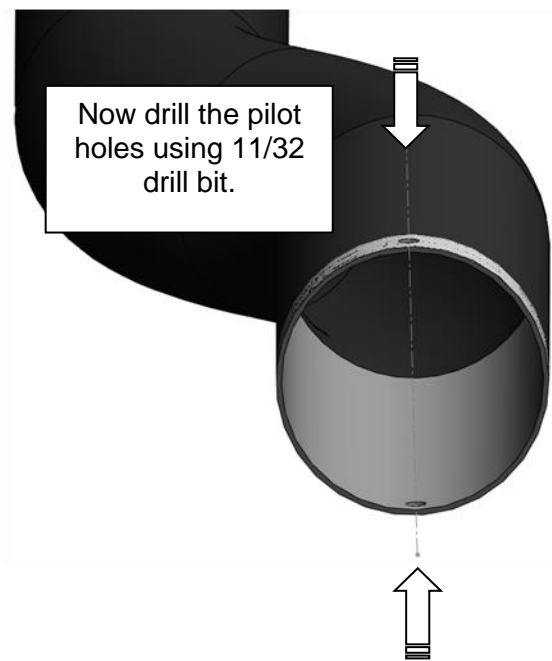

9. Once the holes are drilled, install the ring bead around the pipe. Lock each end of the ring bead into each hole.

You can use needle nose pliers to tweak or adjust the ring fit slightly.

Be careful not to bend the ring bead too much as you will weaken it.

Note the ring bead does not have to be perfectly tight or snug around the pipe, as we will be installing a silicone boot over top of it.

With the ring bead in place, you should not be able to pull the ring bead off axially from the tube.



10. Slide one 0300 clamp onto the pipe then install the step boot (#1302272) onto the pipe over the bead ring.

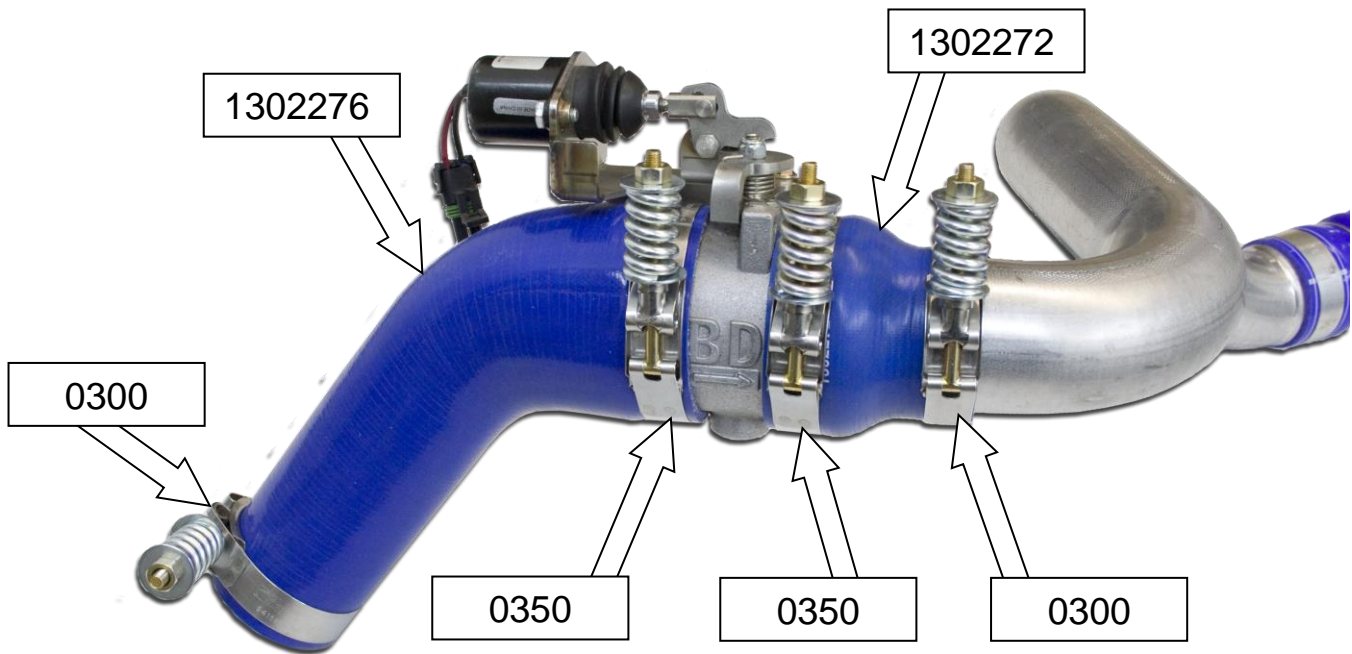
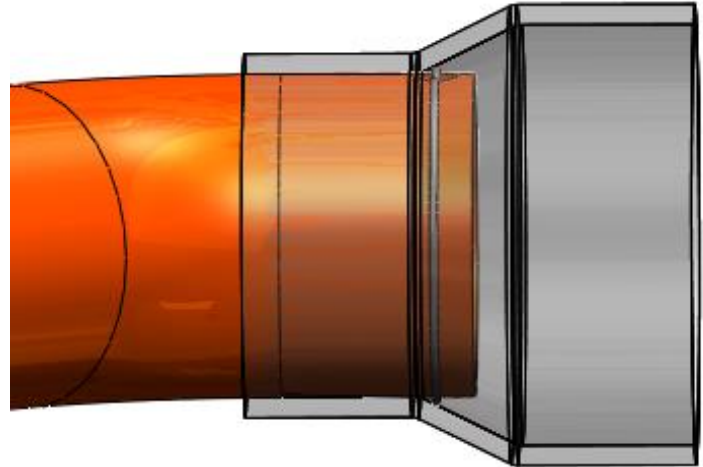

11. Once the boot and clamp are in place you can install the valve ensuring the flow orientation arrow on the side of the casting points towards the CAC. Then install the elbow boot with the supplied clamps. Leave all clamps loose until proper in vehicle fit can be determined.

Please note the flow orientation.



12. Install PAS tube assembly into the vehicle CAC side first. Note that you will need to rotate the tubes you achieve perfect alignment. Once you are happy with fit and the PAS unit will not contact any other components or vibrations. Tighten all spring clamps until the spring is spring bound.

13. Lay out supplied wiring harness over top of the engine.

Locate and connect the weather pack connector on the wiring harness to the solenoid on the PAS valve. See page 30 for more info.

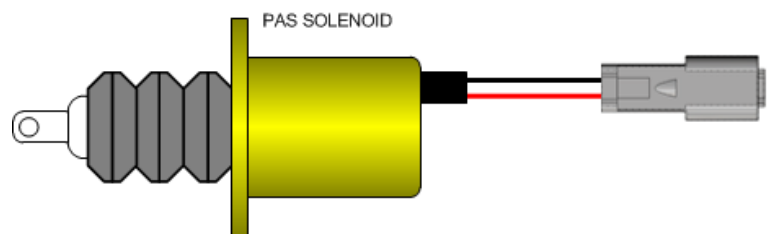

14. You will then need to route the switch wires through the firewall on the driver's side.

Choose a highly visible location for the switch and mount it to the dash.

NOTE: You may need to trim the switch wires to length once you have located where the switch is to be mounted.

Using a 1/8" drill, drill a pilot hole in the location you have selected for the switch to be mounted.

Finally using a 1/2" UNIBIT drill bit, drill an exact 1/2" round hole.

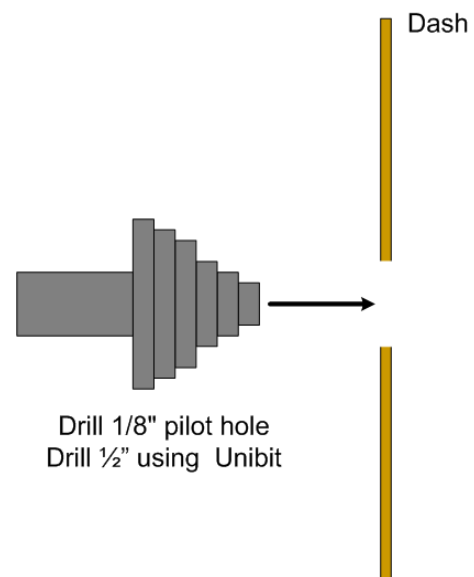

15. Once you have the mounting hole drilled, crimp the switch connectors to the switch wires and install the correct switch wires to the correct switch terminals, then insert the switch into the dash from the backside.

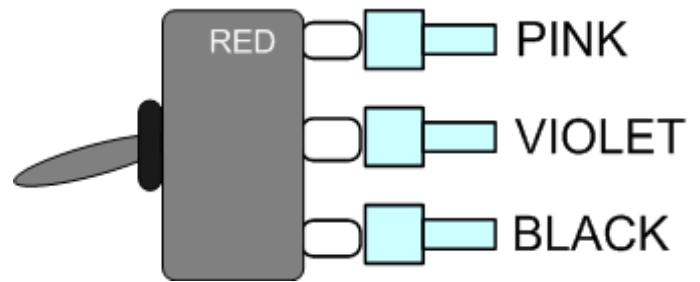

16. Mount the switch so that the groove on the thread boss is facing down.

Adjust the HEX washer/nut so that the switch threads do not protrude an unsightly amount.

Switch install with decal

Apply the supplied decal to the dash and tighten the round plastic nut.

Switch install with Guard

Install the switch guard onto the switch by aligning the tab with the groove on the thread boss.

Then tighten on the round plastic nut and apply the decal to the switch guard.

Switch install with Decal

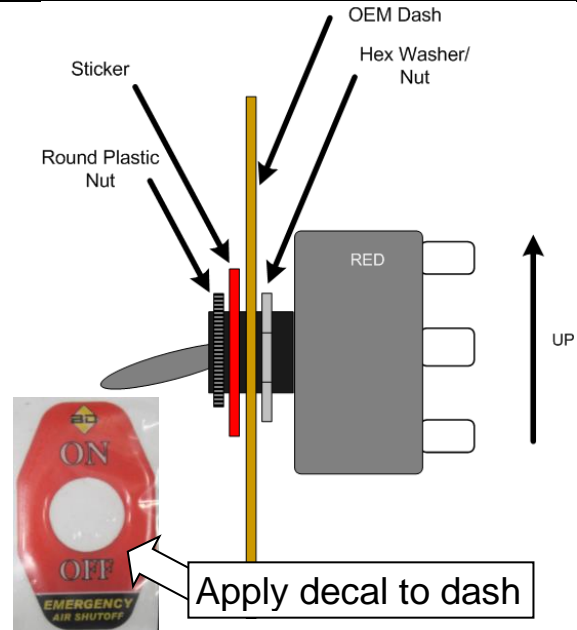

Switch Install with Guard

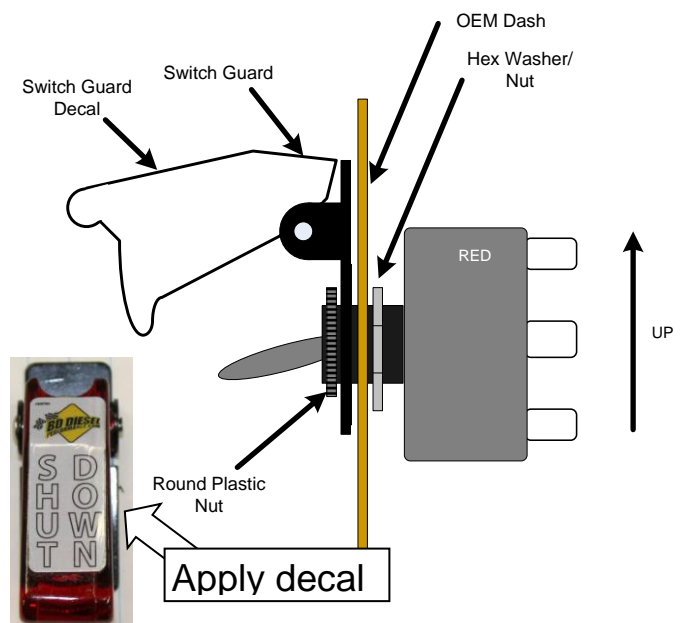

17. Next run the wire for the battery connection then trim and crimp the ring terminals and connect to the respective power and ground connections.

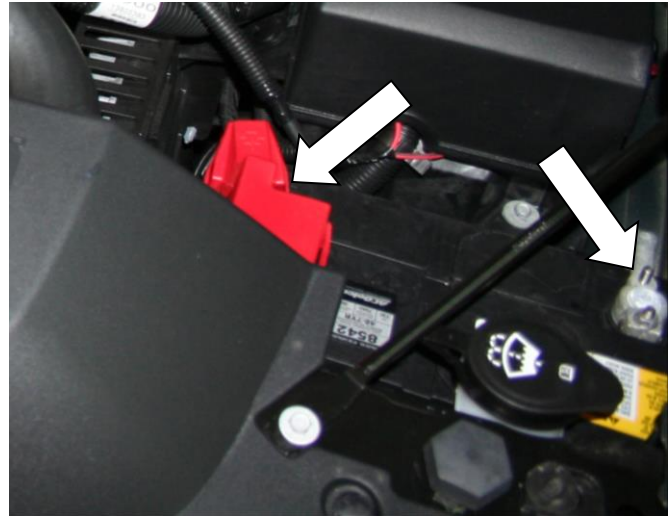

18. For the last connection you will need to locate ignition power.

Locate the battery junction box at the driver's side mid of the engine compartment.

Open the junction box and locate the appropriate fused ignition power circuit (see table below). Install fuse tapper on to fuse, reinstall fuse. Trim the pink wire to length and crimp the flag connector to the wire and connect the pink wire lead wire with flag connector to this new connection.

Route wire out of the box and close lid.

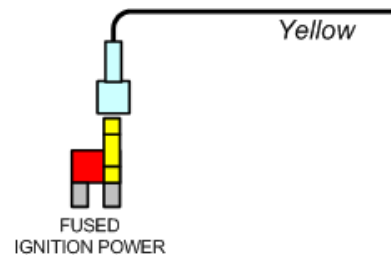
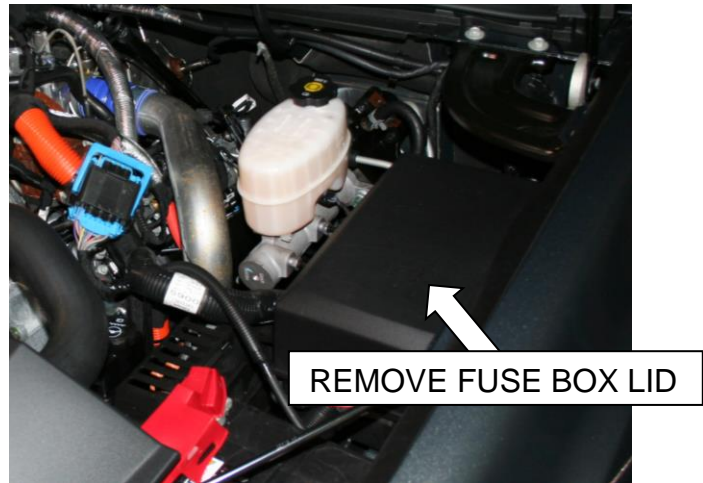

(2011-2014) AUX HVAC-IGN #45 (10AMP)

Pin	Wire Color	Circuit No.	Function
39	RDO Fuse	15A	Digital Radio Receiver (U2K), Radio, Rear Seat Audio (RSA) Control (UK6), Chime Module (UL5)
40	MISC IGN Fuse	10A	Auxiliary Body Control Module (XBCM) (EXP), Stop Lamp Switch, Transfer Case Shift Control Module (NQF or NQH), Trailer Brake Control Module (JL1)
41	L/GATE RELSE Fuse	15A	Not Used
42	AIRBAG BATT Fuse	15A	Inflatable Restraint Passenger Presence System (PPS) Module, Inflatable Restraint Sensing and Diagnostic Module (SDM), Inflatable Restraint Vehicle Roll-over Sensor (ASF)
43	IPC Fuse	10A	Body Control Module (BCM), Instrument Panel Cluster (IPC)
44	EXP/PTO Fuse	15A	Auxiliary Body Control Module (XBCM) (EXP) Power Take Off Relay (PTO)
45	AUX HVAC-IGN Fuse	10A	Instrument Panel Cluster (IPC), Inside Rearview Mirror (ISRV), Heated Steering Wheel Module Control (KA9)
46	CHMSL Fuse	15A	Center High Mounted Stop Lamp (CHMSL)
47	REAR DEFOG Fuse	30A	Rear Window Defogger Grid

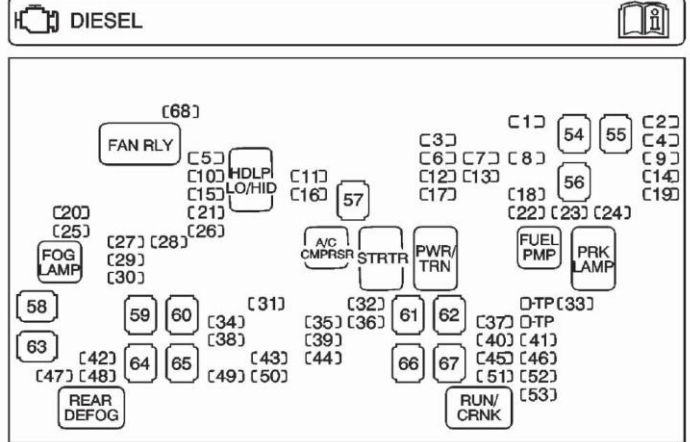

**MINI FUSES
MINI-FUSIBLES**

- 1 - ESC/ALC EXH (30A)
- 2 - TRLR STOP LT (10A)
- 3 - ENG (15A)
- 4 - TRLR STOP RT (10A)
- 5 - FRT WASH (15A)
- 6 - FUEL HTR (15A)
- 7 - TCM-BATT (15A)
- 8 - ABS 2 (25A)
- 9 - TRLR BCK/UP (10A)
- 10 - LO HDLP-LT (20A)
- 11 - ECM-BATT (10A)
- 12 - DSL ECM (30A)
- 13 - TRNS IGN 1 (15A)
- 14 - VEH BCK/UP (10A)
- 15 - LO HDLP-RT (20A)
- 16 - A/C CMPRSR (10A)
- 17 - EMC/THROT CONT (15A)
- 18 - FUEL PUMP (25A)
- 19 - ITBC (15A)
- 20 - HDLP WASH (20A)
- 21 - REAR WASH (15A)
- 22 - TRLR PRK (15A)
- 23 - LT PRK (15A)
- 24 - RT PRK (15A)
- 25 - FOG LAMP (15A)
- 26 - HORN (15A)
- 27 - HI HDLP (15A)
- 28 - DRL (15A)
- 29 - HI HDLP-LT (10A)
- 30 - DRL 2 (15A)
- 31 - S/ROOF (30A)
- 32 - DLIS (2A)
- 33 - WPR (25A)
- 34 - SEO B2 (30A)
- 35 - EAP (15A)
- 36 - HVAC BATT (10A)
- 37 - AIRBAG IGN (10A)
- 38 - AMP (30A)
- 39 - RDO (15A)
- 40 - MISC IGN (10A)
- 41 - L/GATE RELSE (15A)
- 42 - AIRBAG BATT (15A)
- 43 - IPC (10A)
- 44 - EXP/PTO (15A)
- 45 - AUX HVAC-IGN (10A)
- 46 - CHMSL (15A)
- 47 - REAR DEFOG (30A)
- 48 - HTD MIR (15A)
- 49 - SEO B1 (15A)
- 50 - LTR (20A)
- 51 - SEO/ALC (10A)
- 52 - HVAC-IGN (10A)
- 53 - ECM-IGN (15A)
- 54 - ALC/COMP (40A)
- 55 - HEAVY DUTY ABS (60A)
- 56 - ABS-1 (40A)
- 57 - STRTR (40A)
- 58 - STUD-2 (30A)
- 59 - LBEC1 (60A)
- 60 - ELEC RUN BOARD (30A)
- 61 - WSW/HTR (60A)
- 62 - TREC (30A)
- 63 - STUD-1 (40A)
- 64 - MBEC1 (60A)
- 65 - HVAC BLWR (40A)
- 66 - LGM (30A)
- 67 - LBEC2 (60A)

**J-CASE FUSES
FUSIBLES JCASE**

- 54 - ALC/COMP (40A)
- 55 - HEAVY DUTY ABS (60A)
- 56 - ABS-1 (40A)
- 57 - STRTR (40A)
- 58 - STUD-2 (30A)
- 59 - LBEC1 (60A)
- 60 - ELEC RUN BOARD (30A)
- 61 - WSW/HTR (60A)
- 62 - TREC (30A)
- 63 - STUD-1 (40A)
- 64 - MBEC1 (60A)
- 65 - HVAC BLWR (40A)
- 66 - LGM (30A)
- 67 - LBEC2 (60A)



(2015) MISC-IGN #39 (15AMP)

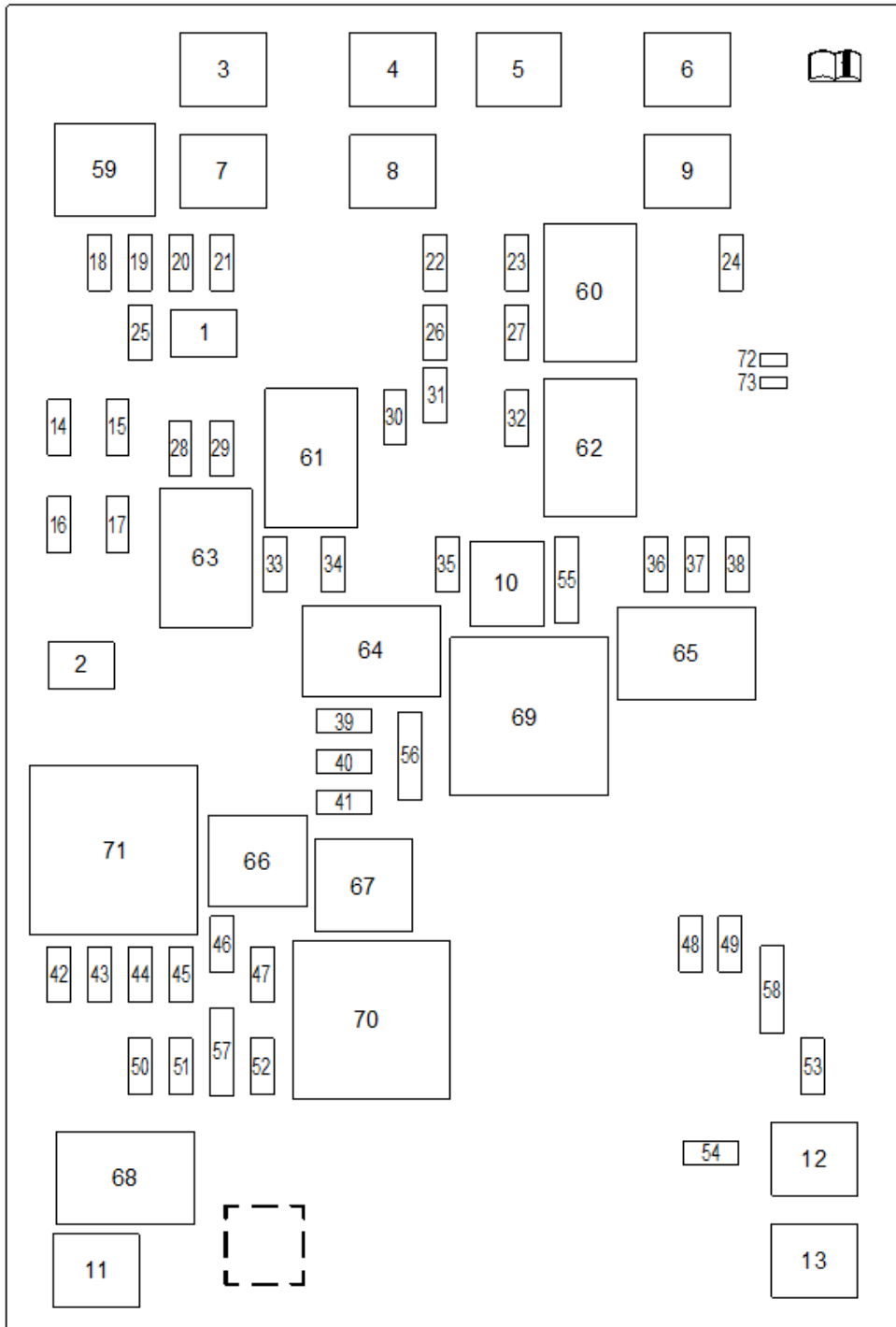

- 7. ELEC PRK BRK (40A)
- 8. I/P BEC 2 (80A)
- 9. MSB DRVR (40A)
- 10. REAR DEFOG (30A)
- 11. STRTR (40A)
- 12. COOL FAN 1 (40A)
- 13. COOL FAN 2 (40A)

MINI FUSES 2 PIN

- 14. TRLR STOP TRN LT (10A)
- 15. TRLR PRK LAMP (20A)
- 16. REV LAMP (10A)
- 17. TRLR STOP TRN RT (10A)

MICRO FUSES 2 PIN

- 18. FUEL PUMP (20A)
- 19. ICCM (10A)
- 20. ESC ELC EXH (30A)
- 21. FPPM (30A)
- 22. UPFTR SW1 (5A)
- 23. UPFTR 2 (30A)
- 24. FRT/WPR (25A)
- 25. ABS VLV (25A)
- 26. UPFTR SW2 (5A)
- 27. UPFTR SW3 (5A)
- 28. PR K LAMP RT (15A)
- 29. PR K LAMP LT (15A)
- 30. UPFTR 3 (30A)
- 31. UPFTR SW4 (5A)
- 32. UPFTR 4 (30A)
- 33. BCK UP LAMP (10A)
- 34. ECM IGN (15A)
- 35. A/C CLTCH (10A)
- 36. HTD MIR (15A)
- 37. UPFTR 1 (30A)
- 38. CHMSL (10A)
- 39. MISC IGN (15A)
- 40. TRANS IGN (15A)
- 41. FUEL PUMP 2 (20A)
- 42. COOL FAN CLTCH (10A)
- 43. ENG (15A)
- 44. INJ A ODD (20A)
- 45. INJ B EVEN (20A)
- 46. O2 SNSR B (15A)
- 47. THROT CONT (15A)
- 48. HORN (15A)
- 49. FOG LAMP (15A)
- 50. O2 SNSR A (15A)
- 51. ECM (30A)
- 52. INT HTR (10A)
- 53. ACCY PWR MDL/TPIM PUMP (10A)
- 54. FRT WASH (15A)

MICRO FUSES 3 PIN

- 55. A/C CMPRSR MDL/BATT RVC (5A/5A)
- 56. A/C CMPRSR MDL/BATT PCK (10A/10A)
- 57. TCM / ECM (15A/15A)
- 58. HDLP RT / LT (10A/10A)

MICRO RELAYS

- 59. FUEL PUMP
- 60. UPFTR 2
- 61. UPFTR 2
- 62. UPFTR 2
- 63. TRLR PRK LAMPS
- 64. RUN/CRNK
- 65. UPFTR 1
- 66. FUEL PUMP 2
- 67. A/C CNTRL
- 68. STRTR

19. Double check all wiring connections and ensure wires are routed away from any heat sources and moving parts. Then install the loom with the supplied tee connector and clips for the loom ends and continue to the testing flow chart without over speed electronics in this manual.

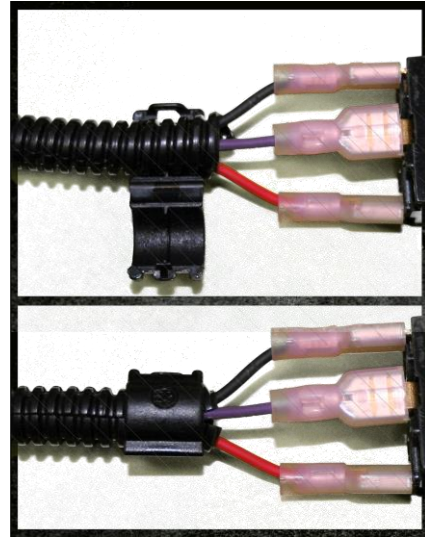
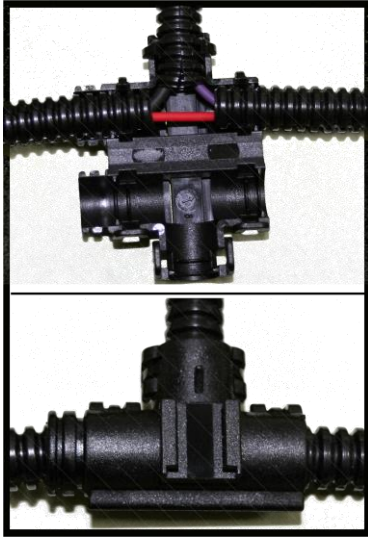

WIRING DIAGRAM with OVER SPEED ELECTRONICS (1036713)

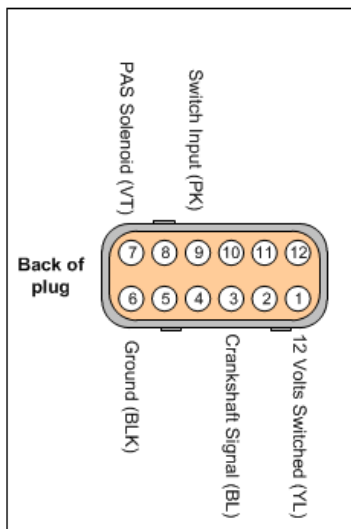
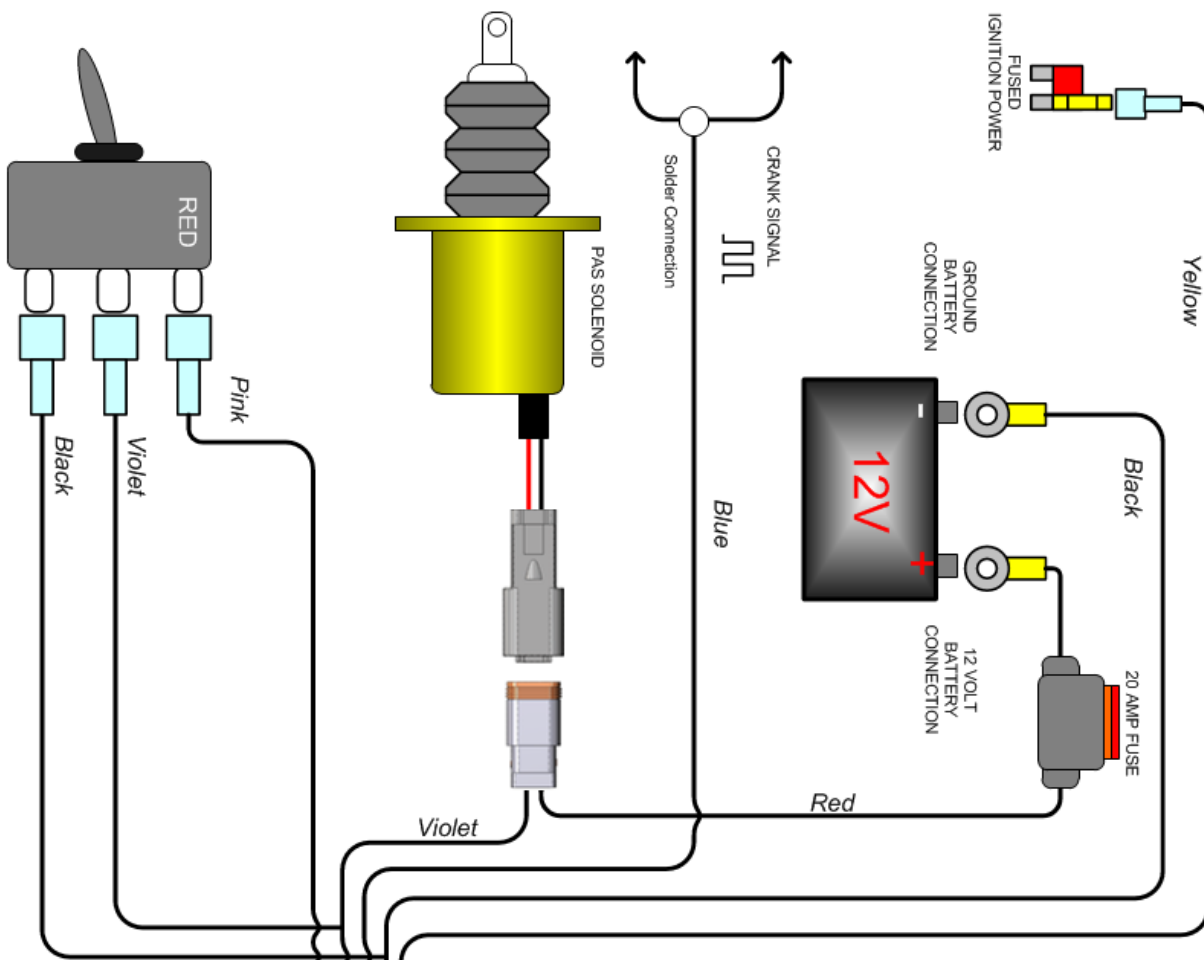

- POSITION 1 = Pre-Programmed Automatic Mode (Vehicle Specific)
- POSITION 2 = Pre-Programmed Test Mode
- POSITION 3 = Full Manual Mode (User must set)

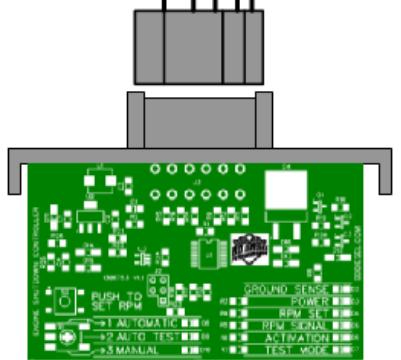

Application	Cutout RPM	Cutout Freq. (Hz)	Idle Freq. (Hz)
Dodge Cummins 1986-97	4200	2300	375
Dodge Cummins 2003-2013	4200	4800	750
Ford 6.7L Powerstroke	5000	4800	675
Ford 6.4L Powerstroke	5000	5000	750
Ford 6.0L Powerstroke	4900	5000	750
Ford 7.3L Powerstroke	4900	850	150
Duramax 6.6L	4800	4800	750

WIRING DIAGRAM without OVER SPEED ELECTRONICS (1036713-M)

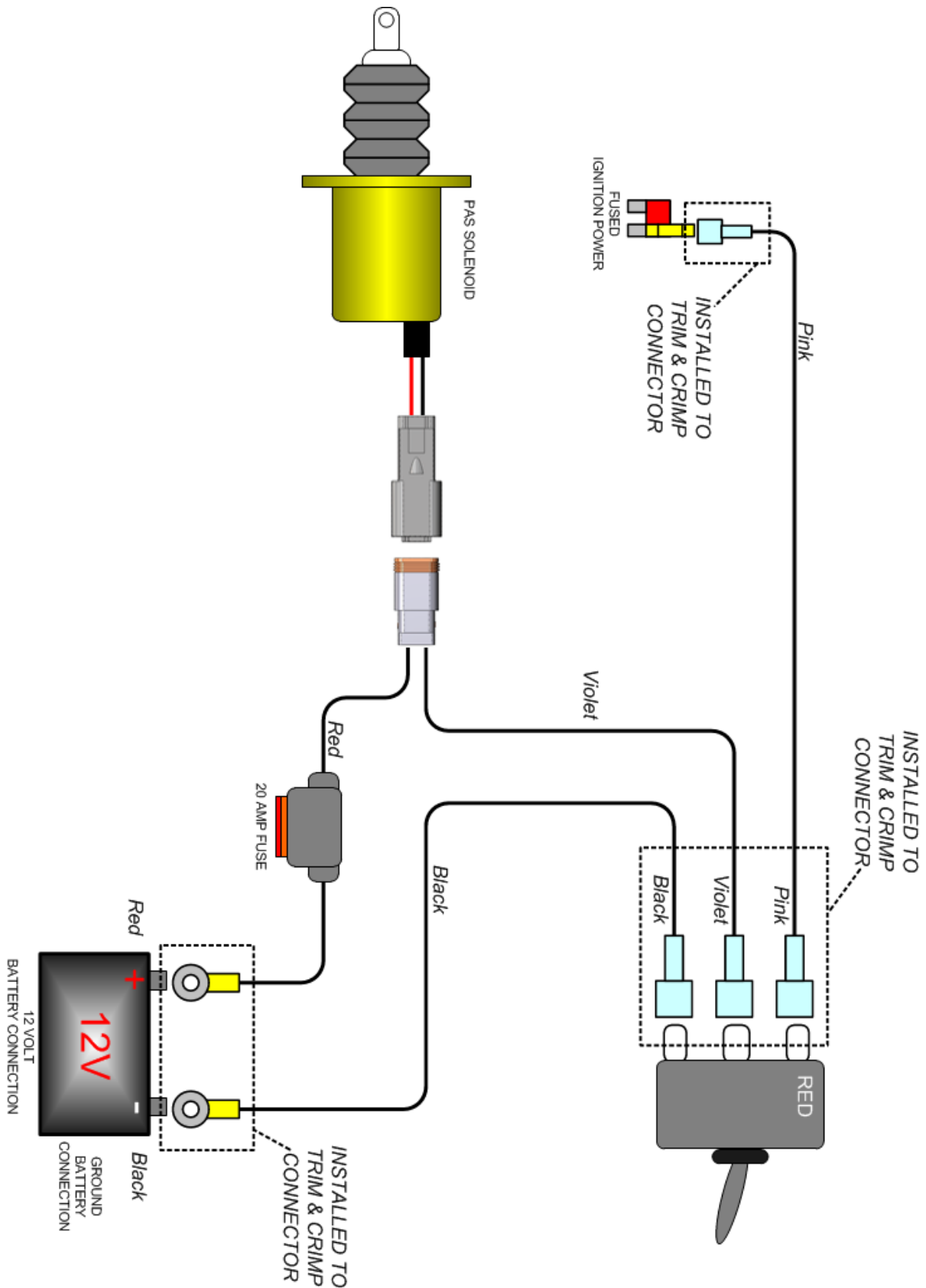

BEAD RING AND DRILL JIG INSTALLATION

- WRAP CORRECT STICKER AROUND PIPE. LINE UP STICK EDGE WITH EDGE OF PIPE. MAKE SURE STICKER IS SQUARE AROUND PIPE AND BOTH ENDS CONNECT
- CENTER PINCH CENTER OF MARKED HOLES
- USE CORRECT SIZE DRILL BIT AND DRILL THROUGH PIPE. ROTATE PIPE AND DRILL THROUGH SECOND MARKED HOLE. THE HOLES SHOULD BE PERFECTLY STRAIGHT
- REMOVE STICKER AND DEBURR INSIDE AND OUTSIDE OF PIPE
- THEN WRAP WIRE BEAD AROUND TUBE. YOU MAY NEED TO FORMAT IT SLIGHTLY. IF DONE CORRECTLY THE BEAD WILL NOT PULL OFF OF TUBE
- INSTALL SILICONE BOOT AND CLAMP AS YOU WOULD NORMALLY

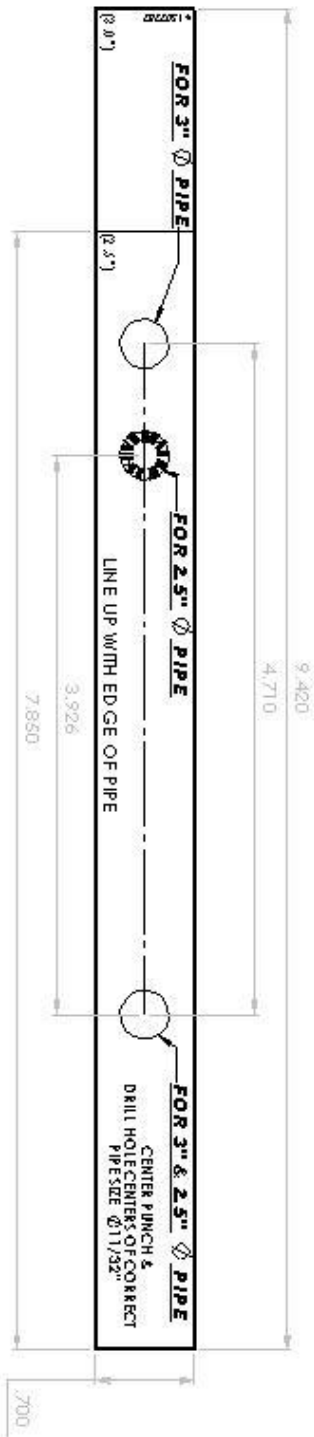
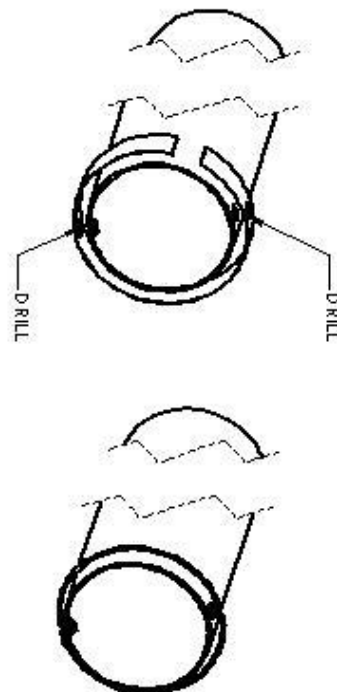

RESETTING THE VALVE

Valve Activated (Closed)

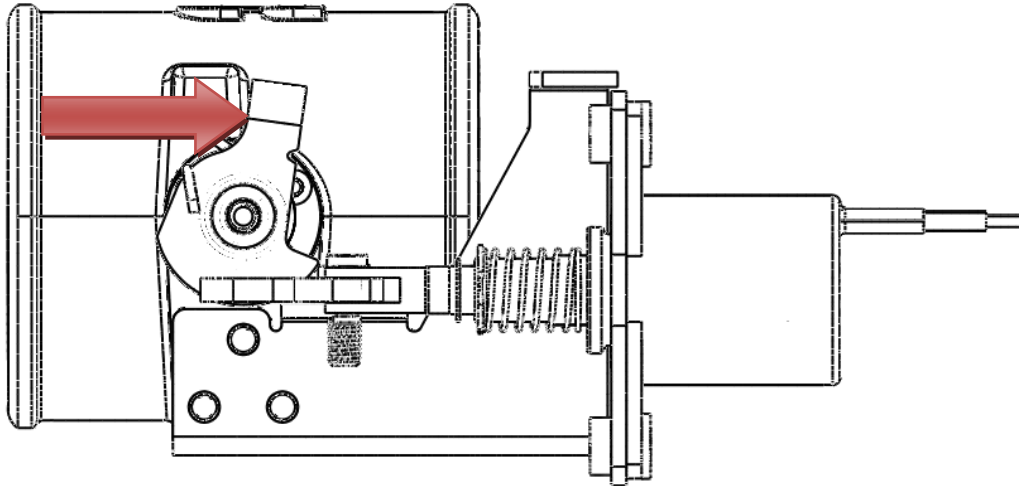

Valve Reset (Open)

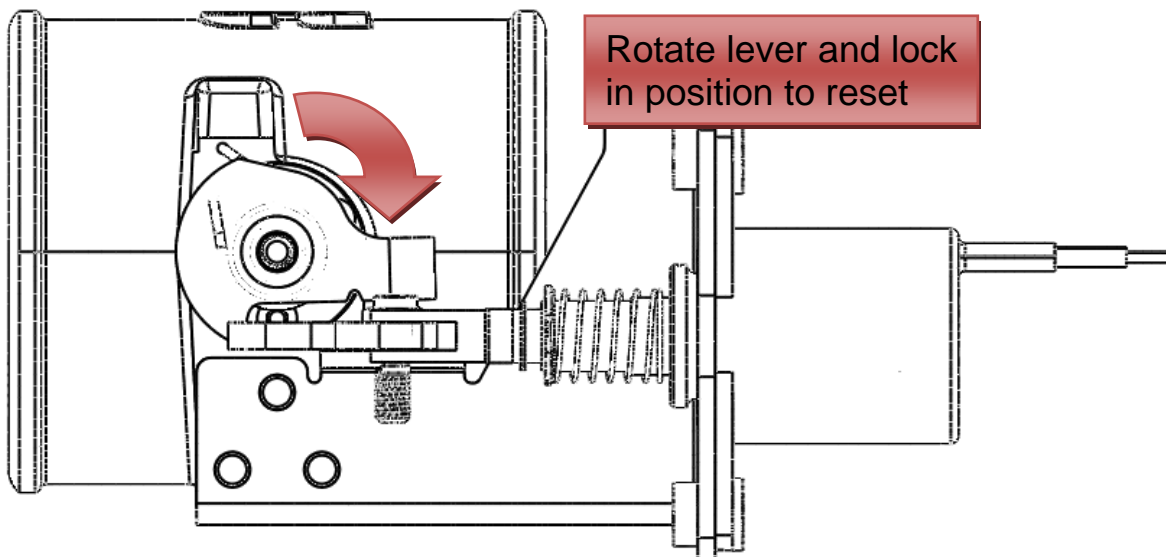

SETUP, TESTING AND VERIFICATION with OVER SPEED ELECTRONICS

Each unit is specifically configured for each model of truck. As in the case of different model years and makes the engine RPM frequency is different.	Engine Idle Speed Frequency
	2011-2015 600-800 Hz (1:1) ratio

2011-2015 Duramax (LML)	Activation RPM	Activation Freq. (Hz)
PAS Switch Position #1 (Automatic Mode)	4600	4600
PAS Switch Position #2 (Test Mode)	1200	1200
PAS Switch Position #3 (Manual Mode)	User Configured	User Configured

Automatic Mode (Pre-Configured RPM)	
Action	Failure/Fix/Notes
1. Start the engine. You should see the RED light illuminate on the toggle switch.	If the LED does not illuminate, check the wiring to the back of the switch first. Then check entire circuit.
2. With the engine idling, activate the toggle switch. You should hear the solenoid activate and the valve close. The engine should die. Once the engine dies the switch should flicker ON and OFF indicating a trip condition.	If the engine does not die, check to make sure the valve actuated. If the valve did not actuate check switch and ground wiring. If valve did actuate but the engine is still running, ensure nothing has contacted the valve mechanism
3. You can now reset the valve, by rotating the upper lever and engaging the solenoid stop.	

- With the valve reset, remove the outer enclosure from the control module. There are two locking tabs on the sides of the enclosure.

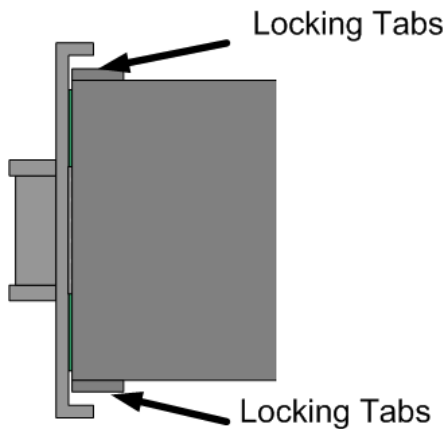

- Change the position selection switch to position #2 (Auto Test). Slide enclosure cover over circuit board.

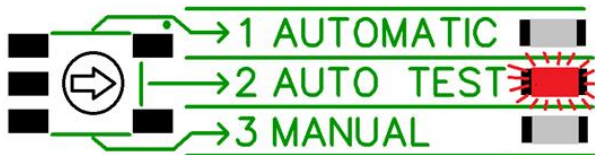
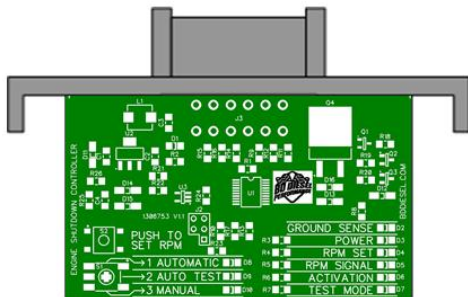

- Start the vehicle, with the vehicle in park step on the throttle increasing the engine RPM. At 1200RPM the PAS should engage itself automatically, and the engine should stall. Like with all activations the toggle switch should flash.

If the engine did not stall, check to make sure the valve actuated. If the valve did not actuate, double check the engine RPM electrical connection. Check the RPM Signal LED on the circuit board, it should flash proportionally to the engine RPM.

7. Reset the valve and reset the mode position switch to position #1

You are now complete and the unit should function correctly. This test cycle should be completed once a year.

Manual Mode (User Configured RPM)

Setup

With the control unit, the user/installer has the ability to set their own activation RPM. It is necessary that you chose a low activation RPM first to test that the unit is operating correctly. Once it is, you will need to set the high limit RPM activation.

Note: When you press the Set button the module will add 25% to the set speed.

1. Open electronic enclosure, by releasing the two locking tabs on the side of the unit.

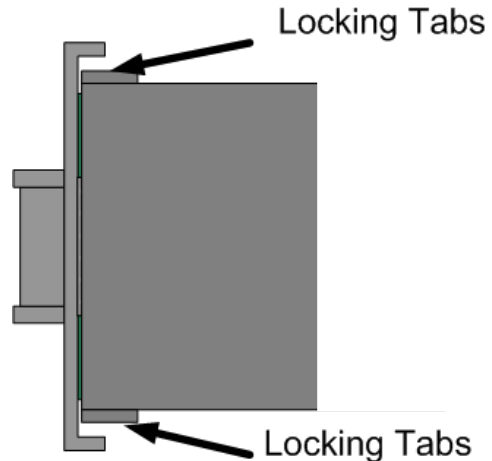

2. Adjust the position switch to position #3.

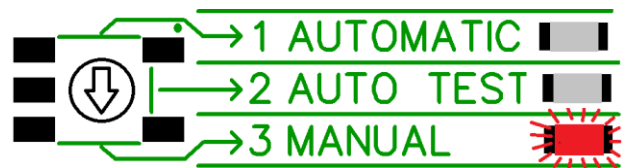

3. Start the engine.

4. Press and hold the RPM SET button.

When you push the SET RPM button will see the "RPM Set" LED illuminate.

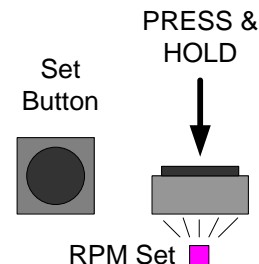

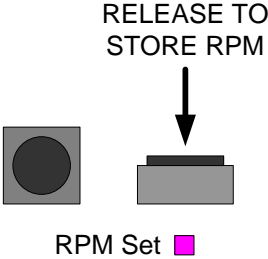
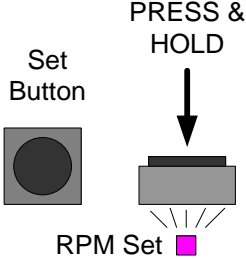
<p>5. With another person helping you, have them step on the accelerator with the vehicle in park. Raise the engine RPM to 1200 RPM.</p> <p>6. Release the SET RPM button.</p> <p>Upon releasing the button, the unit will store the RPM + 25%. For this example the unit has stored 1200RPM + 25% = 1500RPM.</p>	 <p>You should see the RPM signal flash proportionally to engine RPM.</p>
<p>7. Now increase the RPM of the engine to test the activation circuit is working correctly. As in this example the valve should activate at 1500RPM.</p>	<p>You should see the ACTIVATION LED flash ON/OFF on activation.</p> <p>If the valve does not activate check the wiring.</p> <p>If the valve activates but the engine does not stall, ensure nothing has contacted the valve linkage.</p>
<p>8. With the valve activated the engine should die. Reset the valve and restart the engine.</p>	
<p>9. Press and hold the RPM SET button.</p> <p>When you push the SET RPM button will see the “RPM Set” LED illuminate.</p> <p>10. With another person helping you, have them step on the accelerator with the vehicle in park. Raise the engine RPM to MAXIMUM engine RPM.</p>	

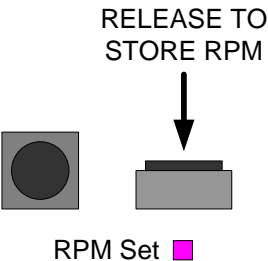
<p>11. Release the SET RPM button.</p> <p>Upon releasing the button, the unit will store the RPM + 25%. For this example, the unit has stored MAXIMUM engine RPM + 25%.</p>	
<p>12. You can now put the electronic enclosure back together and secure it the fuse box.</p>	
<p>13. With the engine running you will need to test to make sure the manual activation switch is functioning correctly.</p> <p>14. With the engine running, lift the activation switch and the engine should die.</p> <p>15. Reset the valve and you are now complete.</p>	<p>If valve does not activate check the wiring.</p> <p>If the valve activates and the engine does not die ensure nothing has contacted the linkage.</p>
<p>You have now completed the installation, please be sure to complete the test once a year to make sure the unit is functioning correctly.</p>	

TESTING FLOW CHART with OVER SPEED ELECTRONICS

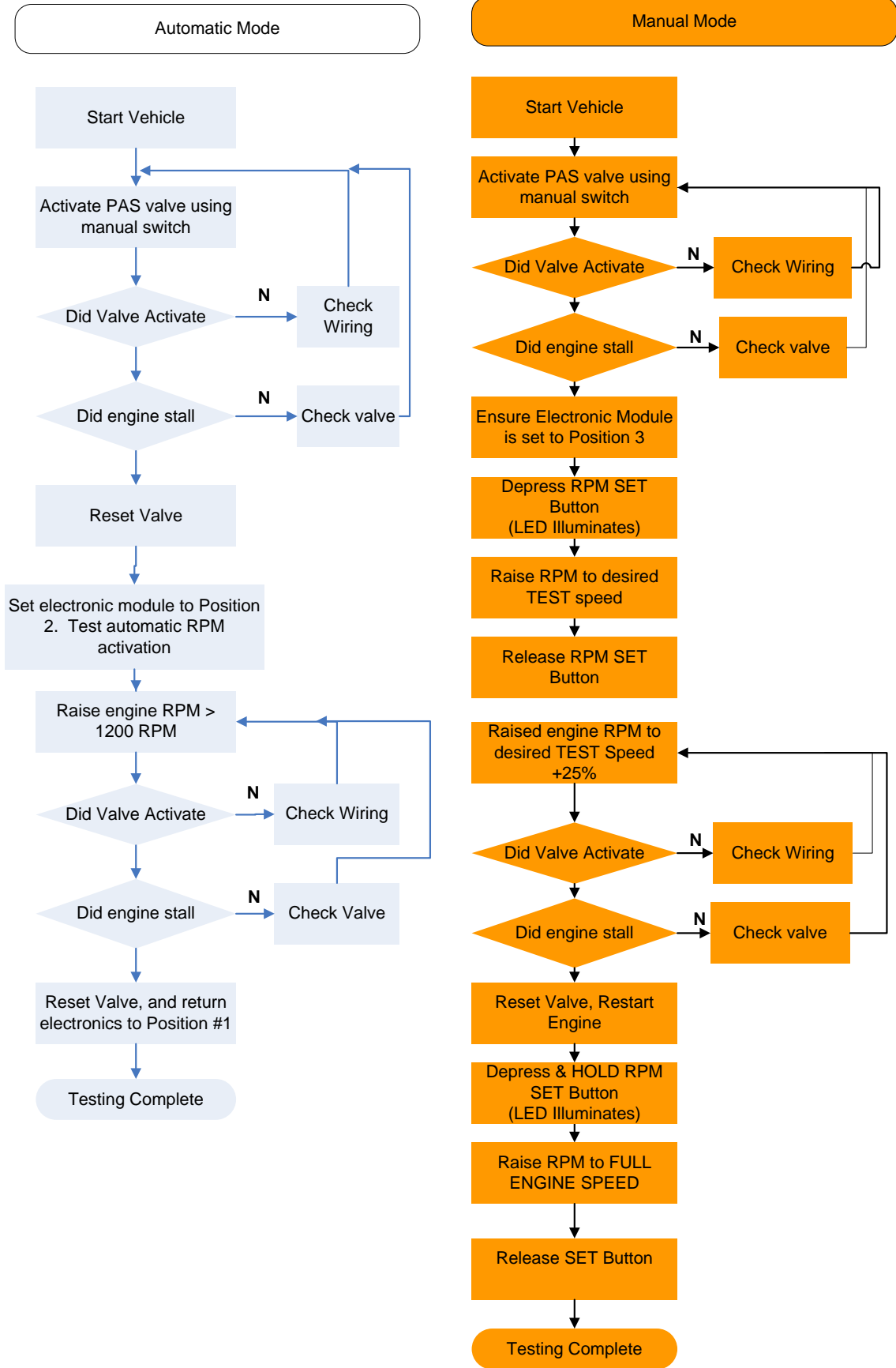

TESTING FLOW CHART *without OVER SPEED ELECTRONICS*

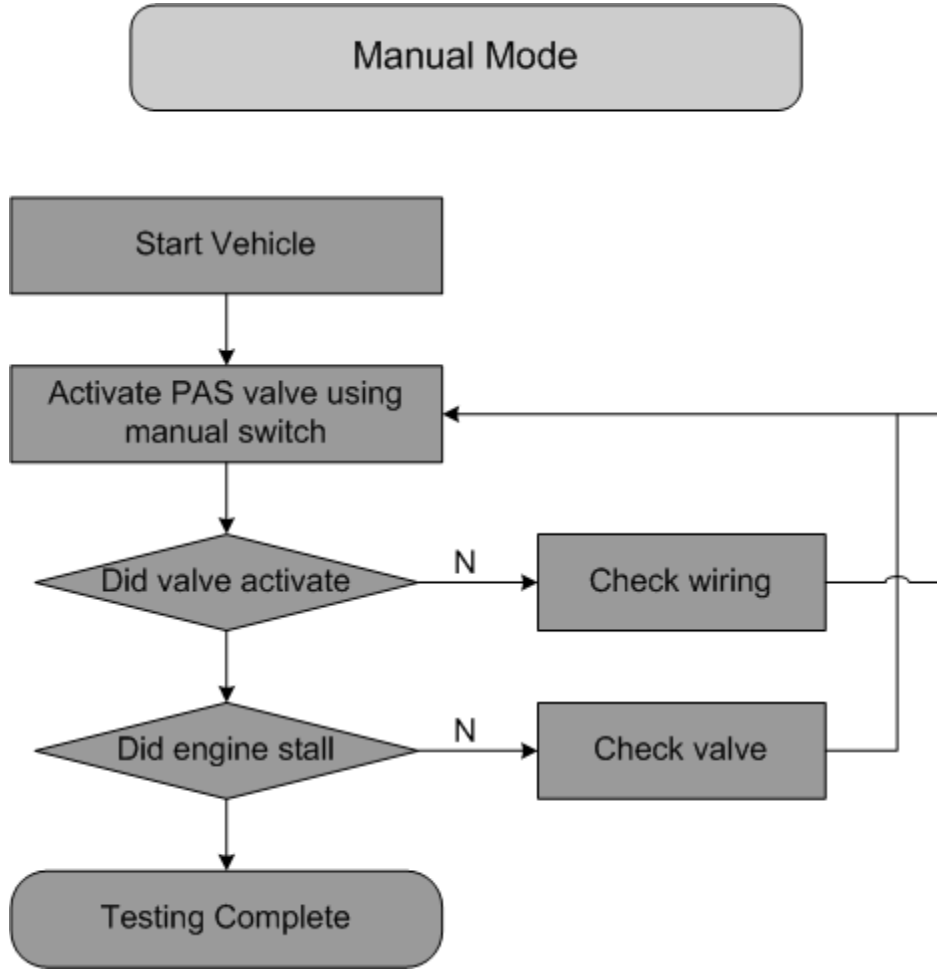

BD ENGINE BRAKE, INC.

Plant Address: A10-33733 King Rd, Abbotsford, BC, Canada V2S 7M9

US Shipping Address: 1124 Fir Avenue, Blaine, WA 98230 US Mailing Address: PO Box 231, Sumas, WA 98295

Phone: 604-853-6096 Fax: 604-853-8749 Internet: www.bddiesel.com

PCB LED Operation

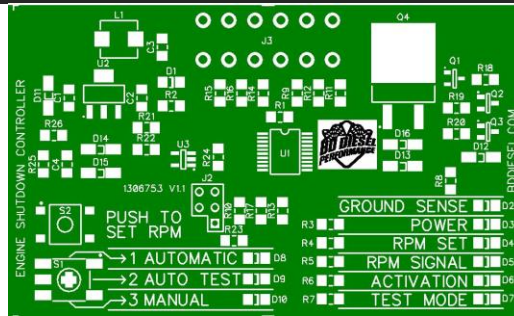

GROUND SENSE	Illuminates when PAS solenoid ground wire is grounded (activated). Normally off. Will light when shutdown switch triggered or module triggers the solenoid.
POWER	Illuminated when the module is powered (switched ignition).
RPM SET	Lights up while the SET RPM button is held down.
RPM SIGNAL	Flashes proportional to engine RPM signal.
ACTIVATION	Flashes when the PAS solenoid has been activated.
1 AUTOMATIC 2 AUTO TEST 3 MANUAL	These LEDs simply confirm the switch position.

If you have any technical difficulties, concerns, comments, or complaints, please phone our Technical Support hotline at (800) 887-5030 between 8:30am-5:00pm PST (Pacific Standard Time) Monday to Friday.