

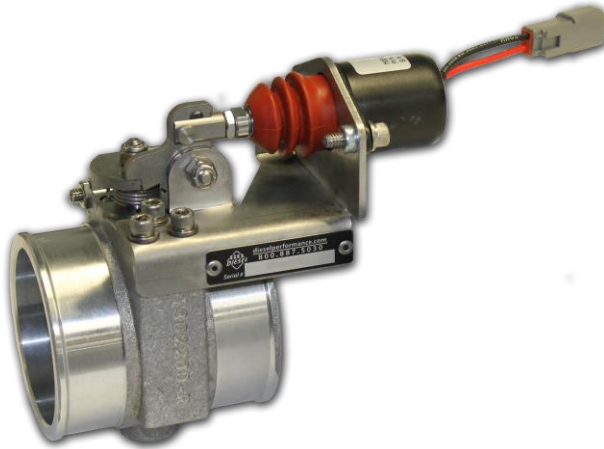

**DOWNLOAD COLOUR
INSTALL MANUALS AT
www.bddiesel.com**



**2003-2007 Ford 6.0L Powerstroke
Positive Air Shutoff**

P/N#	1036701
P/N#	1036701-M













PLEASE READ ALL INSTRUCTIONS BEFORE INSTALLATION





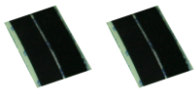



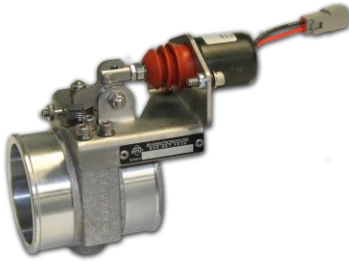

An Information decal has been provided in this kit. This may allow safety personal and inspector's to quickly identify that your vehicle is equipped with a BD Positive Air Shut Down unit. Install this decal in a visible location on the inside glass of the vehicle.

KIT CONTENTS:

Please check to make sure that you have all the parts listed in this kit **before** you start the disassembly of your truck.

1036701 Kit Contents				
1302300-A	1302267	1302245-A	1405404	
				
<i>Air Shutoff Valve</i>	<i>3"-3 1/4" 90° Silicone Boot</i>	<i>Wiring Harness</i>	<i>3"-3 1/4" Silicone Boot</i>	
Qty: 1	Qty: 1	Qty: 1	Qty: 1	
1302266-R	1405211	1407030		
				
<i>Ford 6.0 CAC Pipe</i>	<i>0325 Clamps</i>	<i>0350 Clamps</i>		
Qty: 1	Qty: 4	Qty: 2		
1407003	FT-10910-03116	1301381	1306742	1302285
				
<i>Straight Ribbed Boot</i>	<i>Velcro strips</i>	<i>Heat Shrink</i>	<i>PAS Module</i>	<i>Solder</i>
Qty: 1	Qty: 2 pcs	Qty: 3"	Qty: 1	Qty: 5"

1036701-M Kit Contents			
1302300-A	1302267	1302249-A	1405404
			
<i>Air Shutoff Valve</i>	<i>3"-3 1/4" 90° Silicone Boot</i>	<i>Wiring Harness</i>	<i>3"-3 1/4" Silicone Boot</i>
Qty: 1	Qty: 1	Qty: 1	Qty: 1
1302266-R	1405211	1407030	
			
<i>Ford 6.0 CAC Pipe</i>	<i>0325 Clamps</i>	<i>0350 Clamps</i>	
Qty: 1	Qty: 4	Qty: 2	
			1407003
			
			<i>Straight Ribbed Boot</i>
			Qty: 1

WELCOME

Thank you for purchasing a BD positive air shutoff. This manual is divided into different areas to assist you with your installation and operation of your positive Air shutoff.

This product is a safety product and should be tested often.

Installation should occur on a vehicle properly secured to prevent rolling.

TABLE OF CONTENTS

1036701 Kit Contents	2
1036701-M Kit Contents	3
REQUIRED TOOLS.....	4
MAINTENANCE.....	5
INSTALLATION with OVER SPEED ELECTRONICS (1036701).....	5
INSTALLATION without OVER SPEED ELECTRONICS (1036701-M).....	15
WIRING DIAGRAM with OVER SPEED ELECTRONICS (1036701)	22
WIRING DIAGRAM without OVER SPEED ELECTRONICS (1036701-M)	23
RESETTING THE VALVE.....	24
SETUP, TESTING AND VERIFICATION with OVER SPEED ELECTRONICS.....	25
Automatic Mode (Pre Configured RPM)	25
Manual Mode (User Configured RPM)	27
TESTING FLOW CHART with OVER SPEED ELECTRONICS	30
TESTING FLOW CHART without OVER SPEED ELECTRONICS	31
LED OPERATION.....	Error! Bookmark not defined.

REQUIRED TOOLS

- Frequency/Voltmeter (Optional)
- Drill
- 1/8" Drill Bit
- 1/2" Unibit
- Electrical Tape
- Heat Gun
- Soldering Iron
- Air or Manual Ratchet
- 7/16", 1/2" Sockets
- Wire Strippers
- Wire Cutters

MAINTENANCE

No maintenance is needed other than check to make sure the valve is acting correctly. Please see the testing section later in the manual for the correct procedure.

INSTALLATION with OVER SPEED ELECTRONICS (1036701)

VEHICLE SHOULD BE SAFELY SECURED BEFORE INSTALLATION.

1. Block the wheels of the vehicle to prevent the vehicle from rolling.

Open the hood.

2. Remove driver's side charge air cooler (CAC) pipe and upper silicone boot using a 7/16" socket and ratchet.

Keep all spring clamps as you will be reusing them.

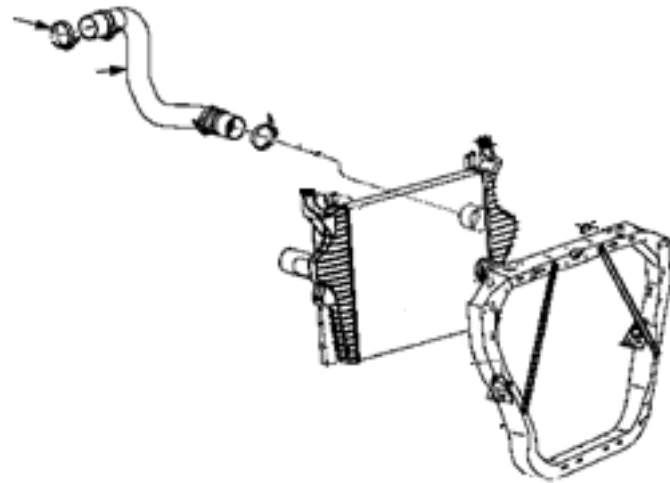

Tighten all spring clamps until spring is bound.

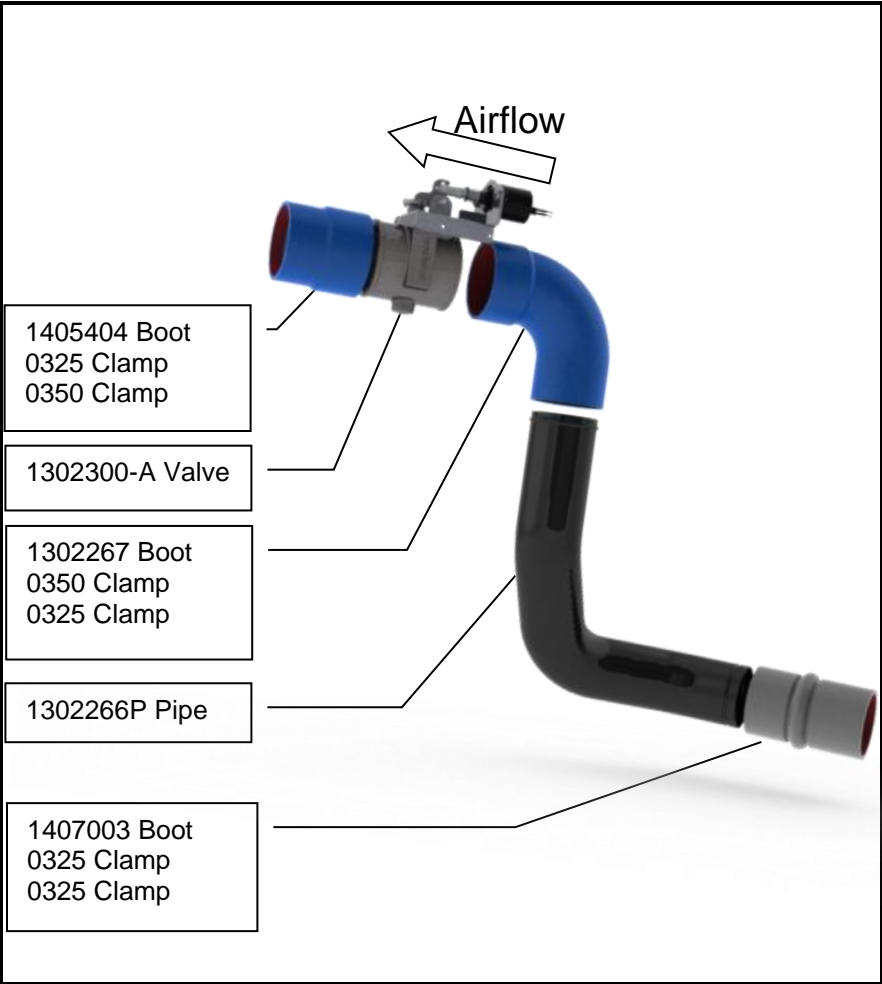

3. First install the new BD lower Charge Air Cooler (CAC) tube (#1302266P) to the CAC. You will utilize the stock clamps and silicone boot for the lower connection. Pay attention the recessed groove of the pipe, this end should connect to the CAC cooler side. The silicon boot should “lock” into the recess groove.
4. Next install the 90° 3-3¼” boot (#1302267), secure this connection with the 0325 clamp (#1405211).
5. Install the PAS valve into the 3 ¼” opening of the 90° boot. Secure this connection with the 0350 clamp (#1407030). Be sure to pay particular attention the flow direction of the valve. Orient that valve so that the solenoid actuator is vertical above the motor.
6. Finally secure the other end of the PAS valve using the 3-3¼” straight boot (#1405404). Use the 0350 clamp (#1407030) on the PAS side of the boot and the 0325 clamp (#1405211) on the intake manifold elbow.
7. Ensure the assembly does not contact anything.



PAS Valve will connect here

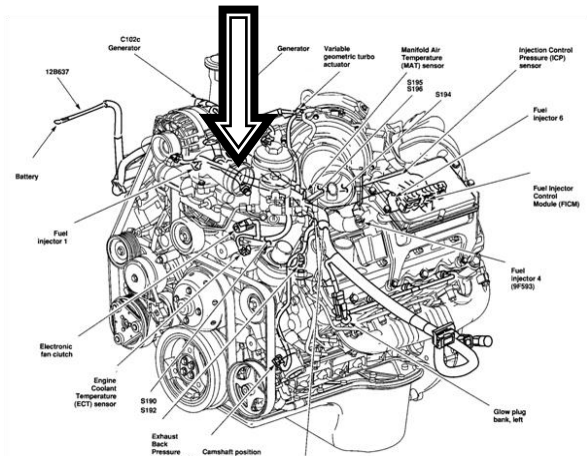

BD ENGINE BRAKE, INC.

Plant Address: A10-33733 King Rd, Abbotsford, BC, Canada V2S 7M9

US Shipping Address: 1124 Fir Avenue, Blaine, WA 98230 US Mailing Address: PO Box 231, Sumas, WA 98295

Phone: 604-853-6096 Fax: 604-853-8749 Internet: www.bddiesel.com

- 8. Lay out supplied harness over top of the passenger's side of the engine.
- 9. You will then need to route the switch wires as well as the yellow ignition power through the firewall on the driver's side (note you will need to remove the switch from the harness to accomplish this). See wiring diagram on page 22

Choose a highly visible location for the switch and mount it to the dash.

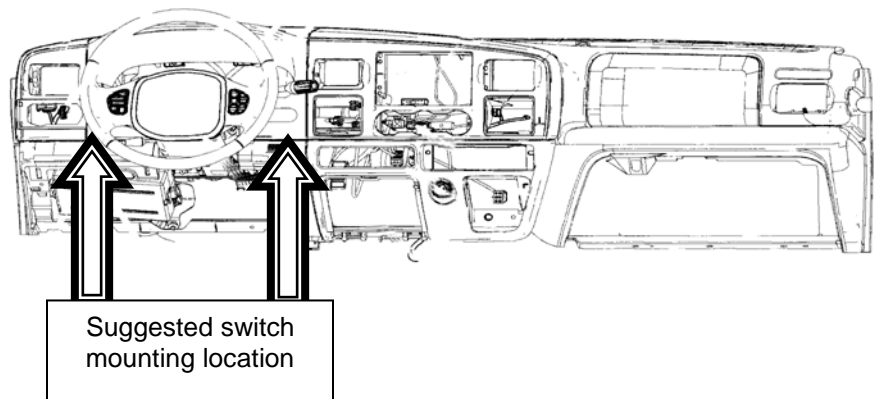
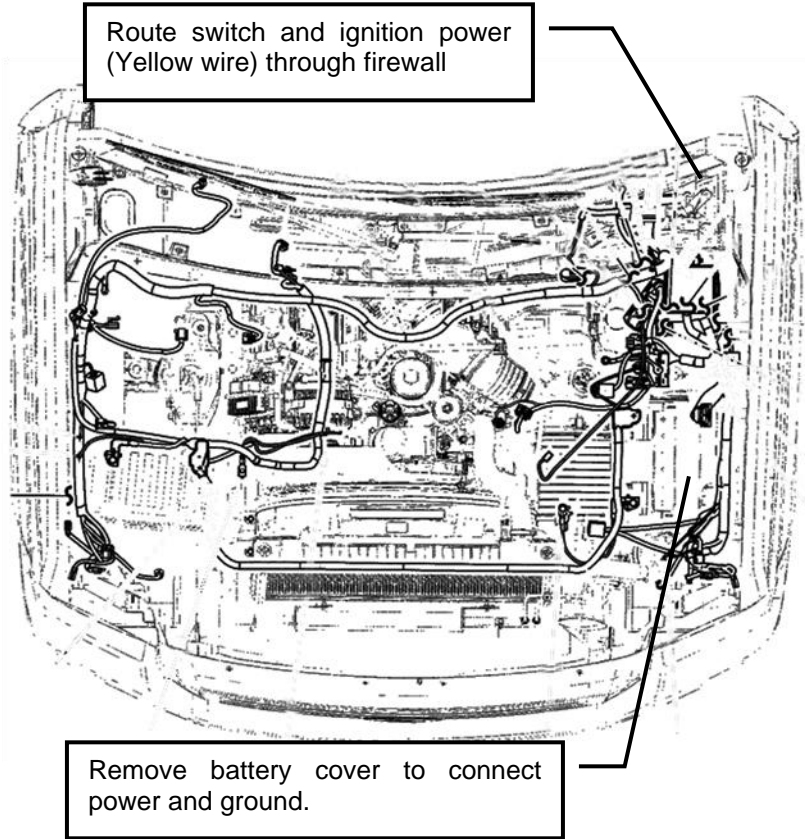

10. Using a 1/8" drill, drill a pilot hole in the location you have selected for the switch to be mounted.

Finally using a 1/2" UNIBIT drill bit, drill an exact 1/2" round hole.

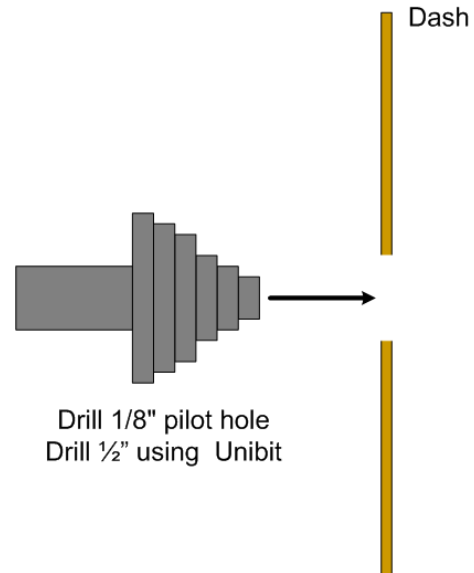

11. Once you have the mounting hole drilled, insert the switch from the backside.

Reinstall the correct wires to the correct switch terminals.

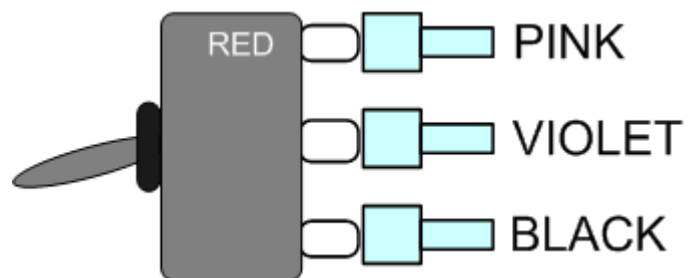

BD ENGINE BRAKE, INC.

Plant Address: A10-33733 King Rd, Abbotsford, BC, Canada V2S 7M9

US Shipping Address: 1124 Fir Avenue, Blaine, WA 98230 US Mailing Address: PO Box 231, Sumas, WA 98295

Phone: 604-853-6096 Fax: 604-853-8749 Internet: www.bddiesel.com

- 12. Mount the switch so that the groove on thread boss is facing down.

Adjust the HEX washer/nut so that the switch threads do not protrude an unsightly amount.

Switch install with decal

Apply the supplied decal to the dash and tighten the round plastic nut.

Switch install with Guard

Install the switch guard onto the switch by aligning the tab with the groove on the thread boss.

Then tighten on the round plastic nut and apply the decal to the switch guard.

Switch install with Decal

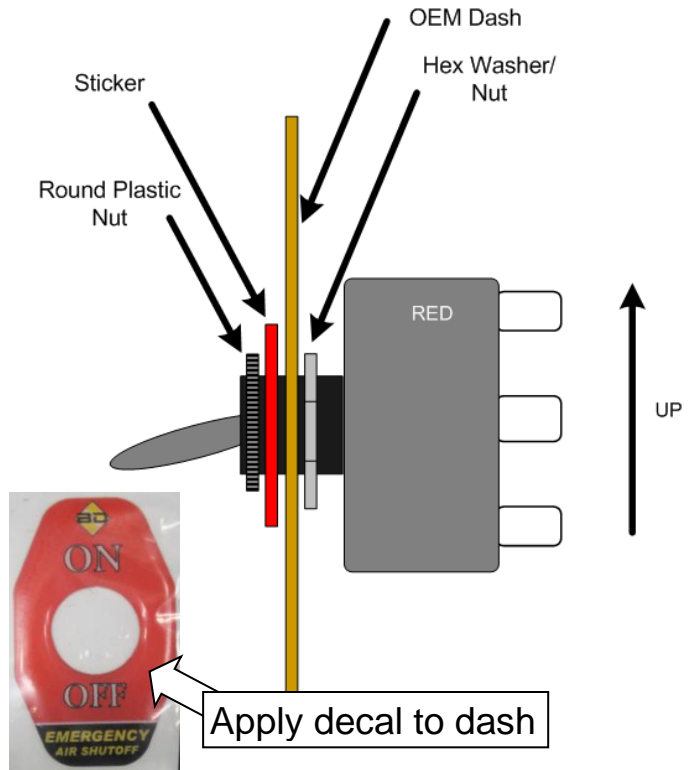

Switch Install with Guard

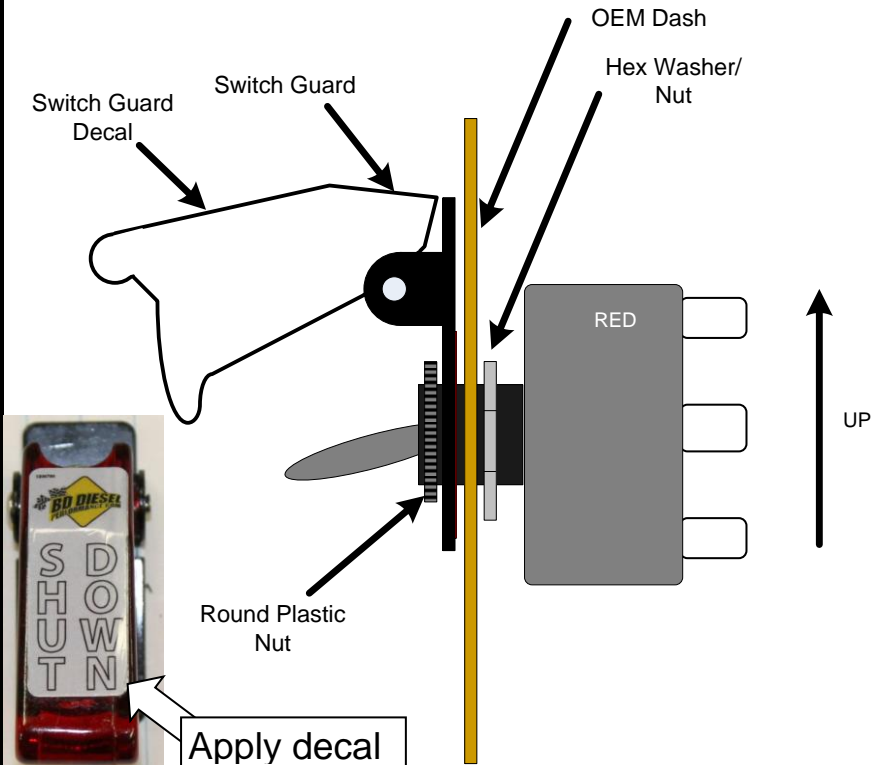

BD ENGINE BRAKE, INC.

Plant Address: A10-33733 King Rd, Abbotsford, BC, Canada V2S 7M9

US Shipping Address: 1124 Fir Avenue, Blaine, WA 98230 US Mailing Address: PO Box 231, Sumas, WA 98295

Phone: 604-853-6096 Fax: 604-853-8749 Internet: www.bddiesel.com

13. Now underneath the hood locate and connect the weather pack connector on the wiring harness to the solenoid on the PAS valve. See page 22 for more info.

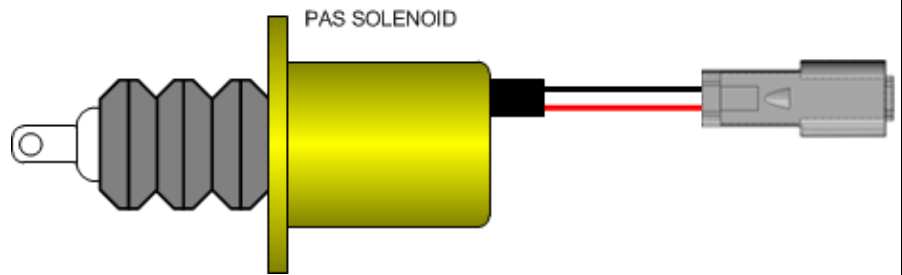

14. You will now need to locate the crankshaft position sensor wire at the PCM.

To access the PCM you will need to remove the driver's side battery cover. It also helps if you remove the battery as well.

Locate the middle connector on the PCM. Finally locate the correct pin and wire color.

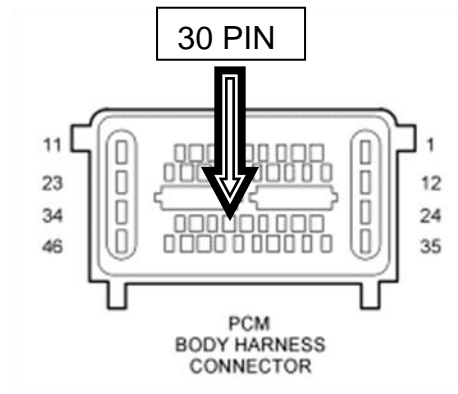
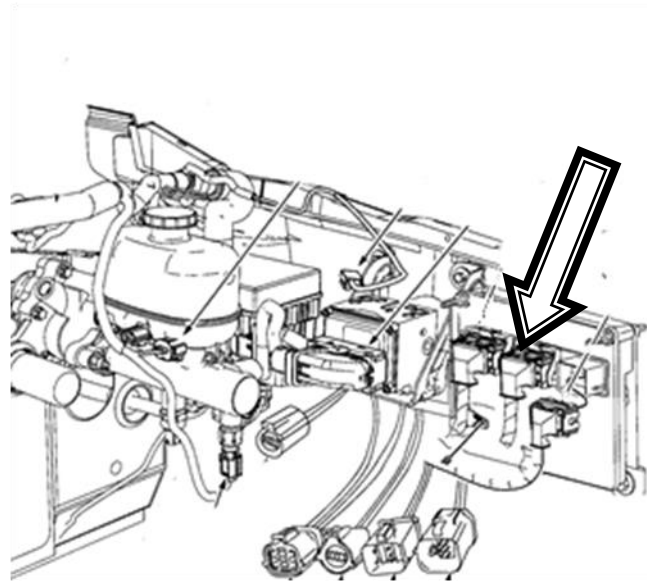

Image is looking at female side of plug. PCM Mate

Year	PCM Pin	Wire Color
2003-2007	30	Dark Blue

15. Being that the RPM signal is critical you will need to solder the connection.

Using wire strippers create a 1" window/gap in insulation of the wire.

Then strip about 1" of insulation of the RPM signal wire of the BLUE wire from the PAS wiring harness.

Wrap the copper wire around the factory RPM signal wire and solder this connection.

Then use electrical tape to wrap this connection so that it is water tight.

You can also cut the factory crank signal wire and use heat shrink tubing if you would like.

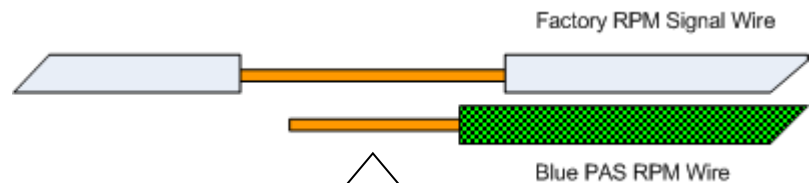

Solder the connection and then wrap and seal with electrical tape

16. Next on the wiring harness connection the BLACK and RED wires to the respective battery connections (Driver's Side Battery).

Don't forget to re-install the battery cover.

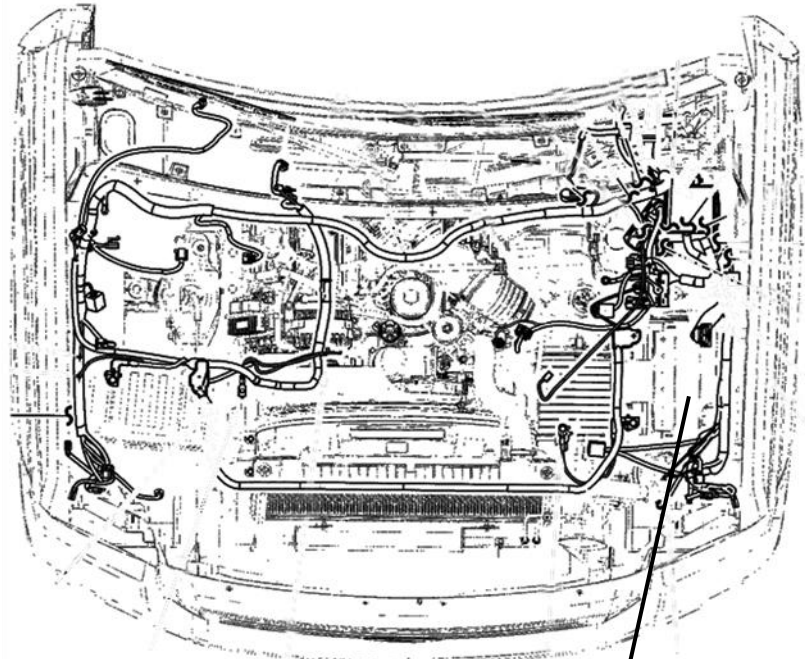

Remove battery cover to connect power and ground.

17. For the last connection you will need to locate ignition power. This will power the automatic over speed control box LED switch. Note that they unit can still be activated manually with the switch at any time.

Locate the kick panel underneath the steering wheel. Remove the kick panel and then the junction box cover.

Locate appropriate fused ignition power circuit. Install fuse tapper on to fuse, reinstall fuse. Connect yellow lead wire with flag

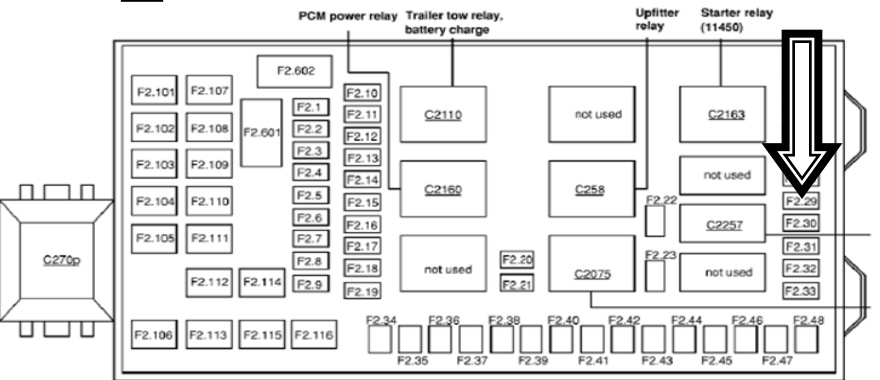
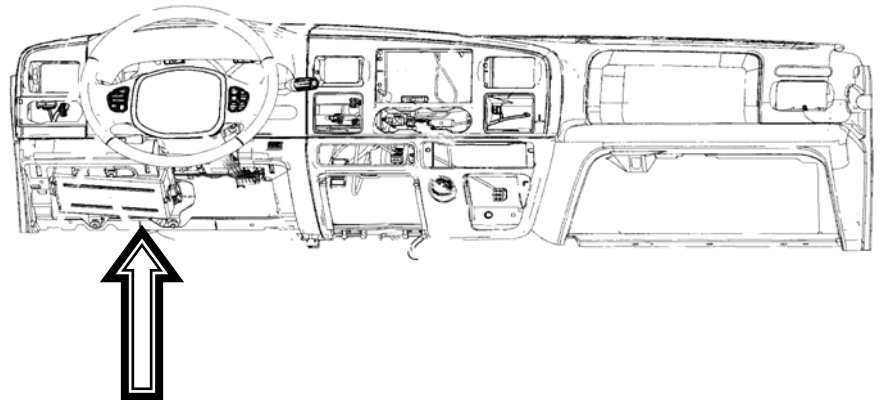

BD ENGINE BRAKE, INC.

Plant Address: A10-33733 King Rd, Abbotsford, BC, Canada V2S 7M9
 US Shipping Address: 1124 Fir Avenue, Blaine, WA 98230 US Mailing Address: PO Box 231, Sumas, WA 98295
 Phone: 604-853-6096 Fax: 604-853-8749 Internet: www.bddiesel.com

connector to this new connection. Route wire out of the box and close lid and kick panel.

Fuse #29 (10 AMP)

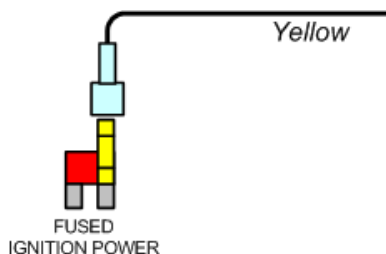

Mount the electronic control unit on the driver's side, to the rear of the battery. Be sure to clean the mounting surface with alcohol before applying Velcro.

Connect the wiring harness to the electronic control unit.

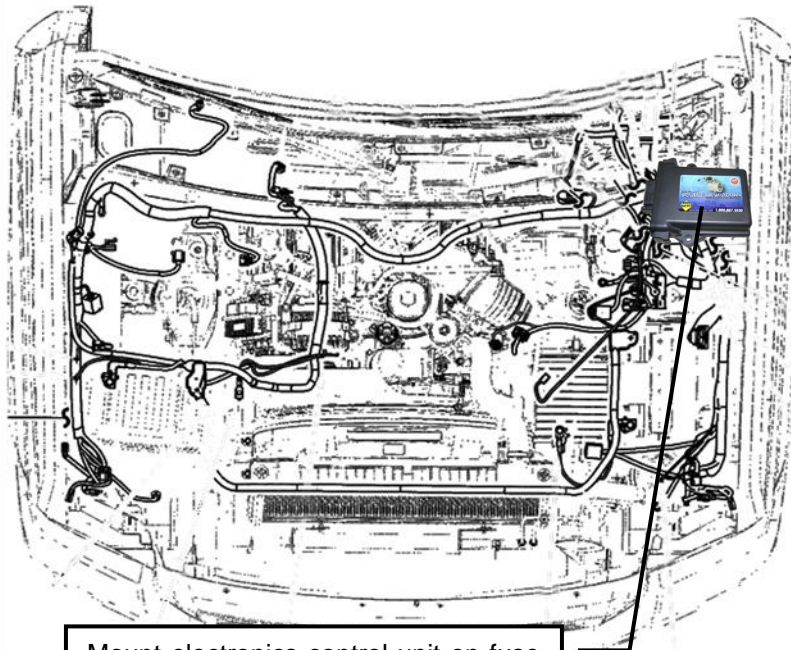

Mount electronics control unit on fuse box using Velcro.

18. Double check all wiring connections and ensure wires are routed away from any heat sources and moving parts.

INSTALLATION without OVER SPEED ELECTRONICS (1036701-M)

VEHICLE SHOULD BE SAFELY SECURED BEFORE INSTALLATION.

1. Block the wheels of the vehicle to prevent the vehicle from rolling.

Open the hood.

2. Remove driver's side charge air cooler (CAC) pipe and upper silicone boot using a 7/16" socket and ratchet.

Keep all spring clamps as you will be reusing them.

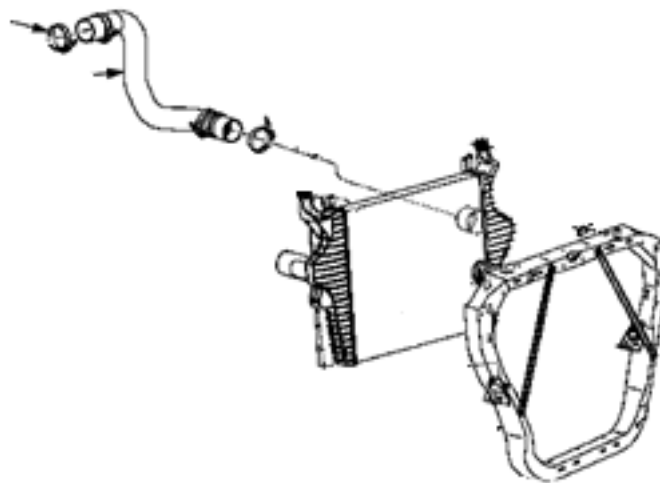

Tighten all spring clamps until spring is bound.

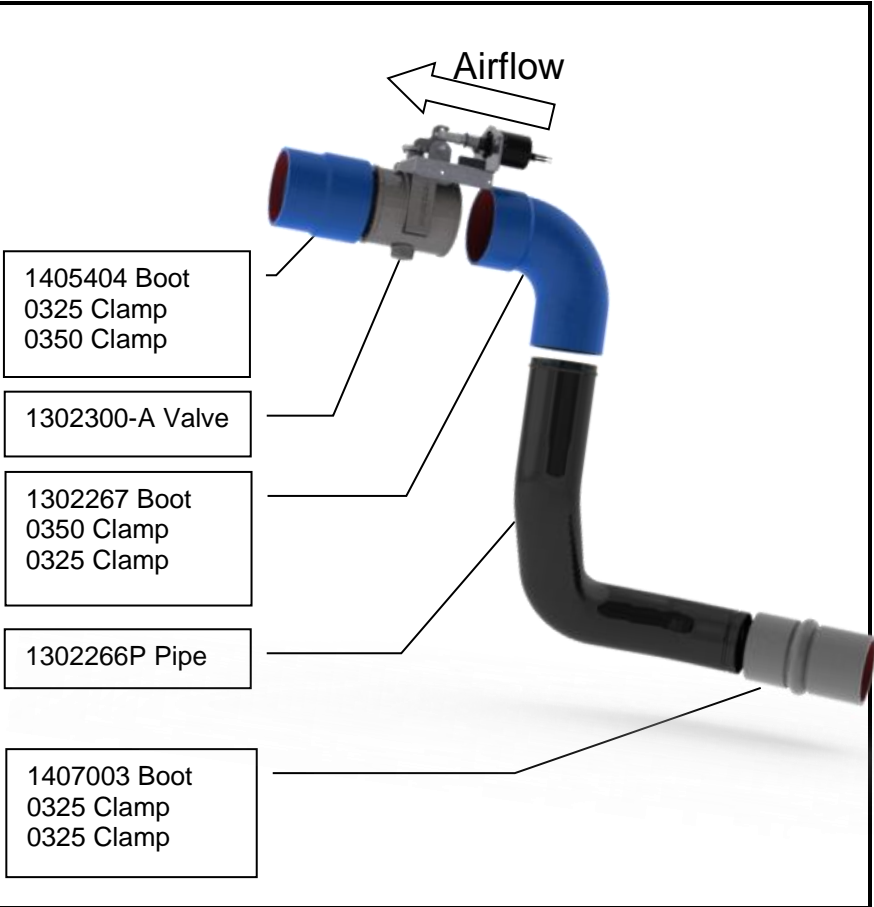

3. First install the new BD lower Charge Air Cooler (CAC) tube (#1302266P) to the CAC. You will utilize the stock clamps and silicone boot for the lower connection. Pay attention the recessed groove of the pipe, this end should connect to the CAC cooler side. The silicon boot should "lock" into the recess groove.
4. Next install the 90° 3-3¼" boot (#1302267), secure this connection with the 0325 clamp (#1405211).
5. Install the PAS valve into the 3 ¼" opening of the 90° boot. Secure this connection with the 0350 clamp (#1407030). Be sure to pay particular attention the flow direction of the valve. Orient that valve so that the solenoid actuator is vertical above the motor.
6. Finally secure the other end of the PAS valve using the 3-3¼" straight boot (#1405404). Use the 0350 clamp (#1407030) on the PAS side of the boot and the 0325 clamp (#1405211) on the intake manifold elbow.
7. Ensure the assembly does not contact anything.



PAS Valve will connect here

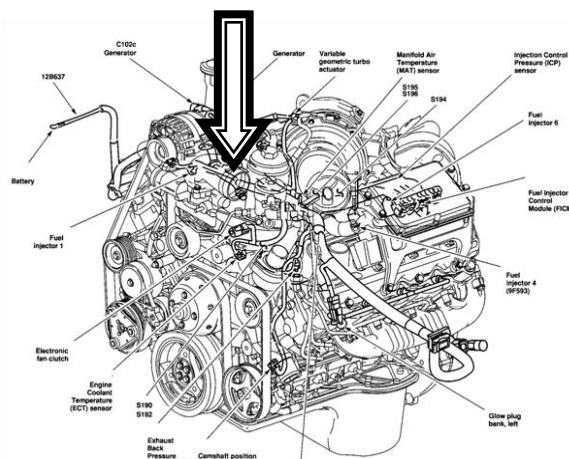

8. Lay out supplied harness over top of the passenger's side of the engine.

Locate and connect the weather pack connector on the wiring harness to the solenoid on the PAS valve. See page 23 for more info.

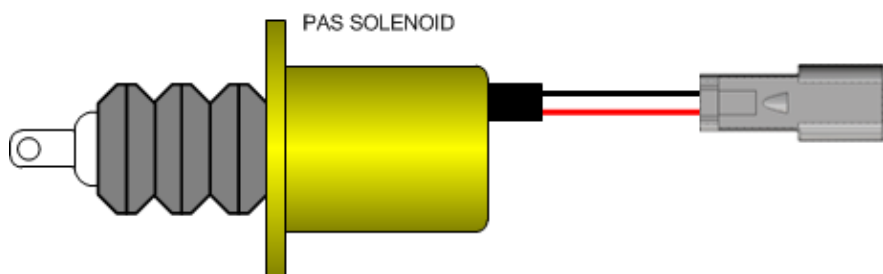

BD ENGINE BRAKE, INC.

Plant Address: A10-33733 King Rd, Abbotsford, BC, Canada V2S 7M9

US Shipping Address: 1124 Fir Avenue, Blaine, WA 98230 US Mailing Address: PO Box 231, Sumas, WA 98295

Phone: 604-853-6096 Fax: 604-853-8749 Internet: www.bddiesel.com

- 9. You will then need to route the switch wires as well as the pink ignition power through the firewall on the driver's side choosing a highly visible location for the switch and mount it to the dash.

NOTE: you may need to trim the switch wires to length once you have located where the switch is to be mounted.

Using a 1/8" drill, drill a pilot hole in the location you have selected for the switch to be mounted.

Finally using a 1/2" UNIBIT drill bit, drill an exact 1/2" round hole.

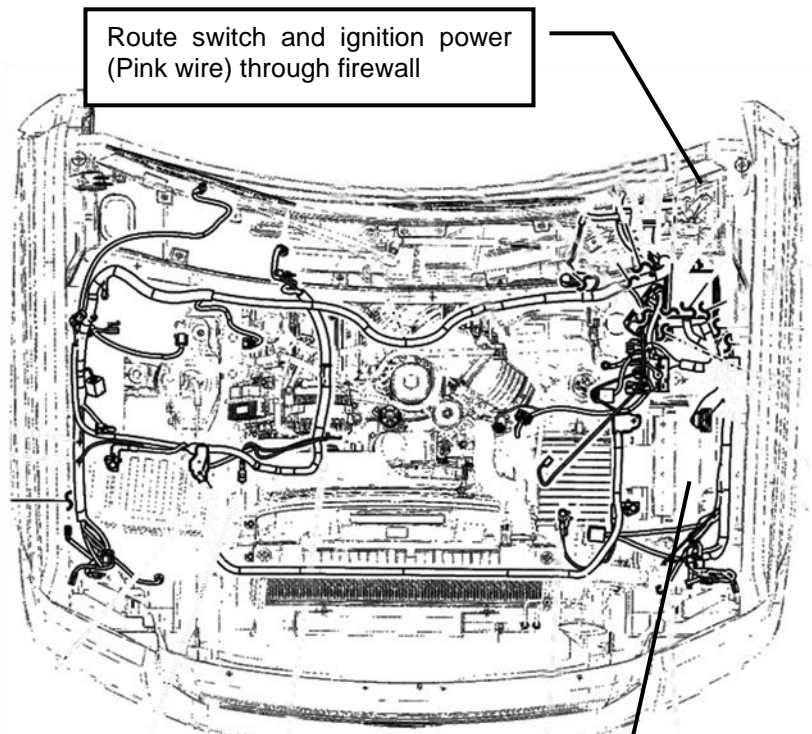

Remove battery cover to connect power and ground.

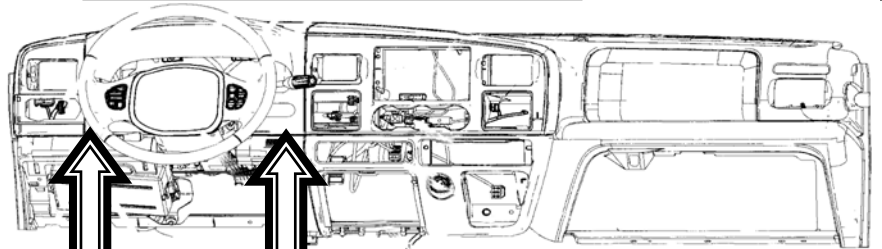

Suggested switch mounting location

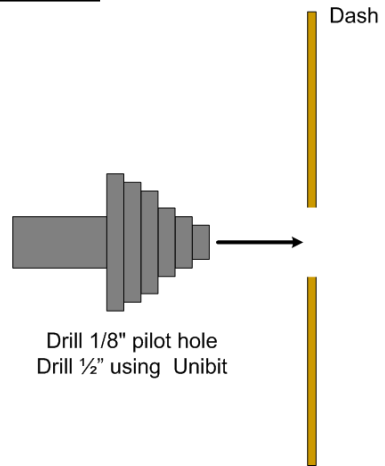

BD ENGINE BRAKE, INC.

Plant Address: A10-33733 King Rd, Abbotsford, BC, Canada V2S 7M9
 US Shipping Address: 1124 Fir Avenue, Blaine, WA 98230 US Mailing Address: PO Box 231, Sumas, WA 98295
 Phone: 604-853-6096 Fax: 604-853-8749 Internet: www.bddiesel.com

10. Once you have the mounting hole drilled, crimp the switch connectors to the switch wires and install the correct wires to the correct switch terminals then insert the switch into the dash from the backside.

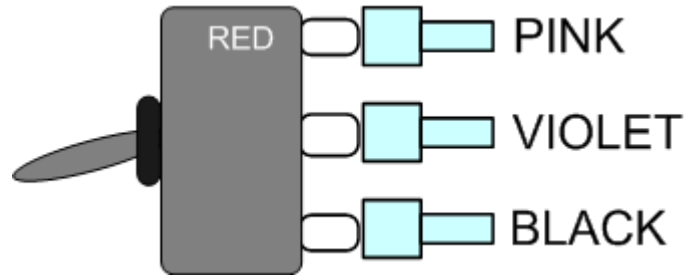

11. Mount the switch so that the groove on thread boss is facing down.

Adjust the HEX washer/nut so that the switch threads do not protrude an unsightly amount.

Switch install with decal

Apply the supplied decal to the dash and tighten the round plastic nut.

Switch install with Guard

Install the switch guard onto the switch by aligning the tab with the groove on the thread boss.

Then tighten on the round plastic nut and apply the decal to the switch guard.

Switch install with Decal

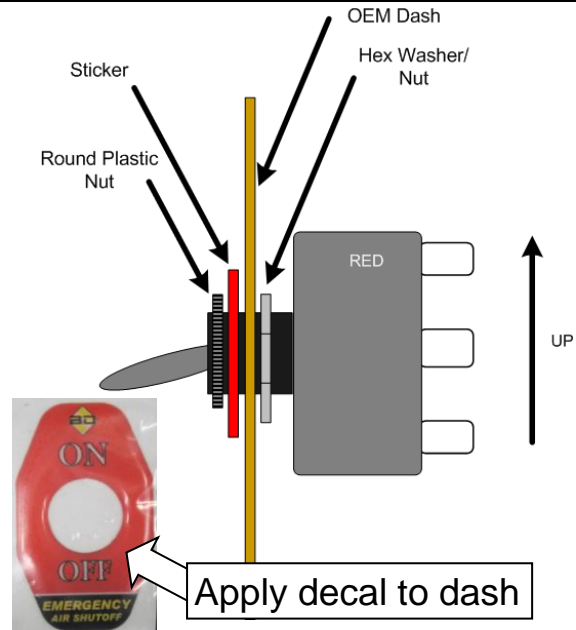

Switch Install with Guard

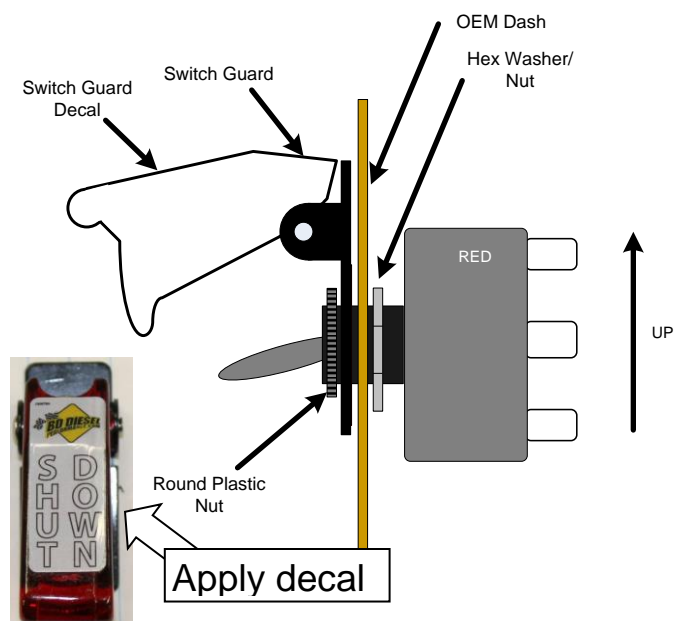

- 12. Next trim the wires to length and crimp the ring terminals to the BLACK and RED wires to connect to the respective battery connections. (Driver's Side Battery).

Don't forget to re-install the battery cover.

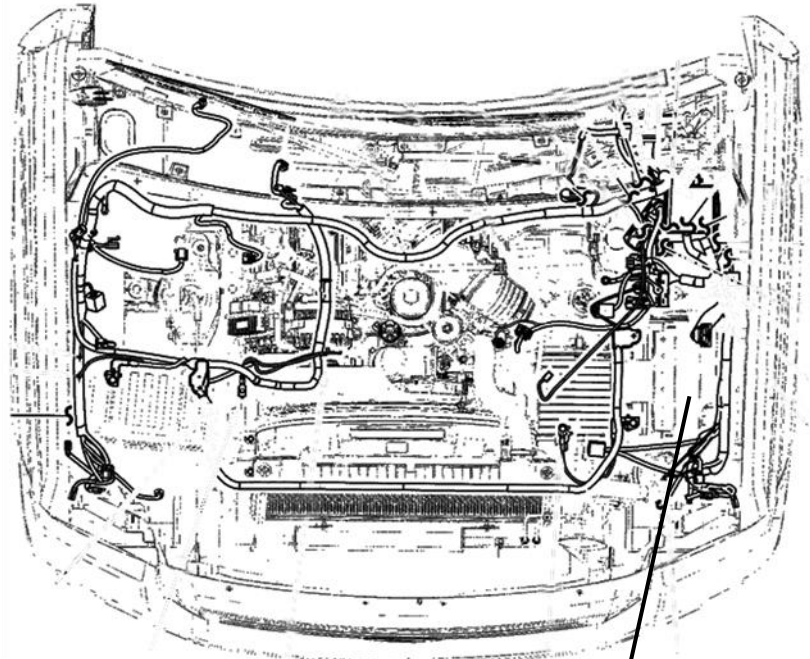

Remove battery cover to connect power and ground.

- 13. For the last connection you will need to locate ignition power.

Locate the kick panel underneath the steering wheel. Remove the kick panel and then the junction box cover.

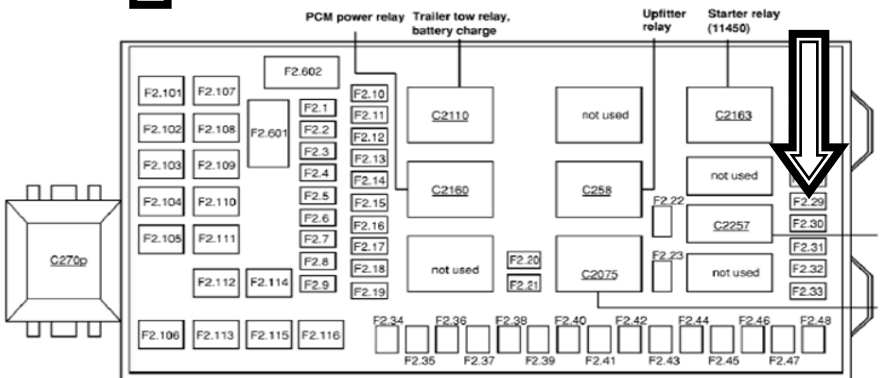
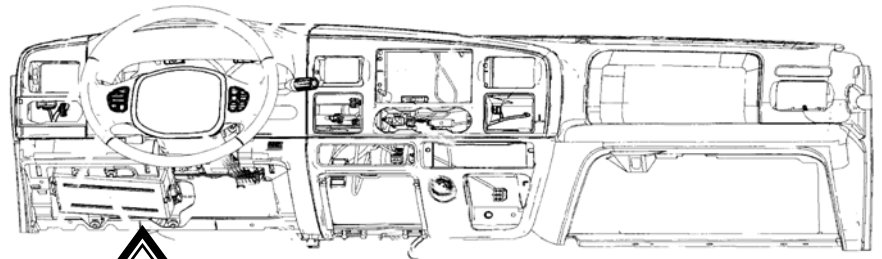

Locate appropriate fused ignition power circuit (see table below). Install fuse tapper on to fuse, reinstall fuse. Trim the pink wire to length and crimp the flag connector to the wire and connect the pink lead wire with flag connector to this new connection. Route wire out of the box and close lid and kick panel.

Fuse #29 (10 AMP)

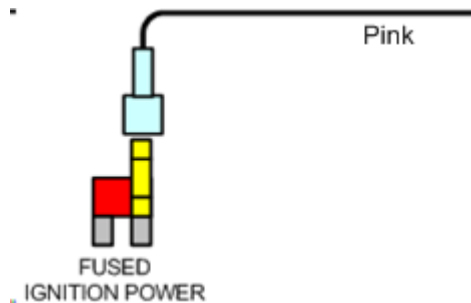

14. Double check all wiring connections and ensure wires are routed away from any heat sources and moving parts. Then install the loom with the supplied tee connector and clips for the loom ends and continue to the testing flow chart without over speed electronics in this manual.

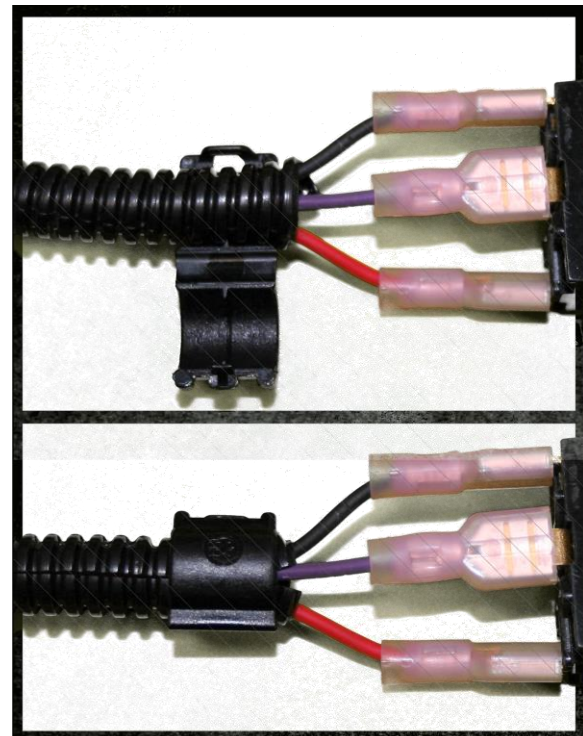
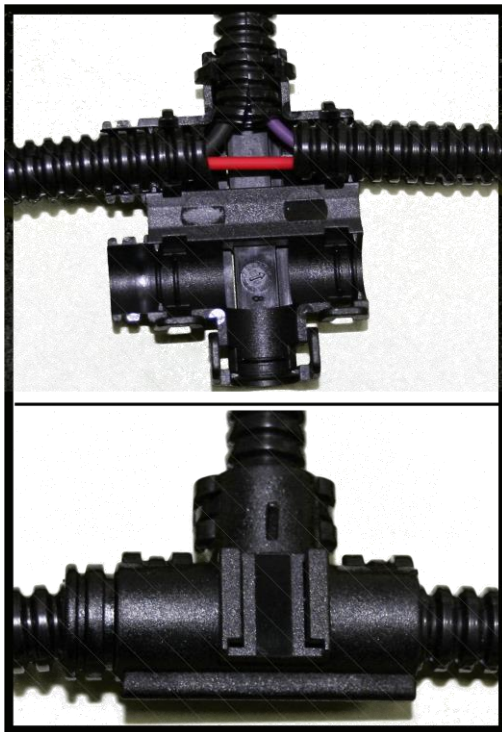

WIRING DIAGRAM with OVER SPEED ELECTRONICS (1036701)

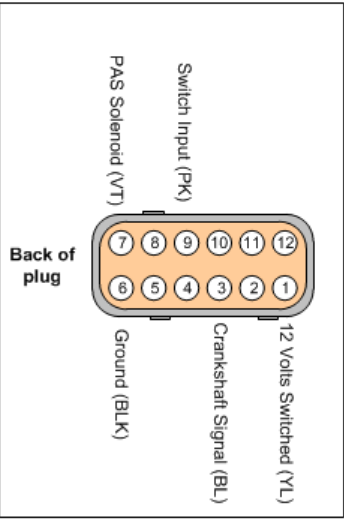
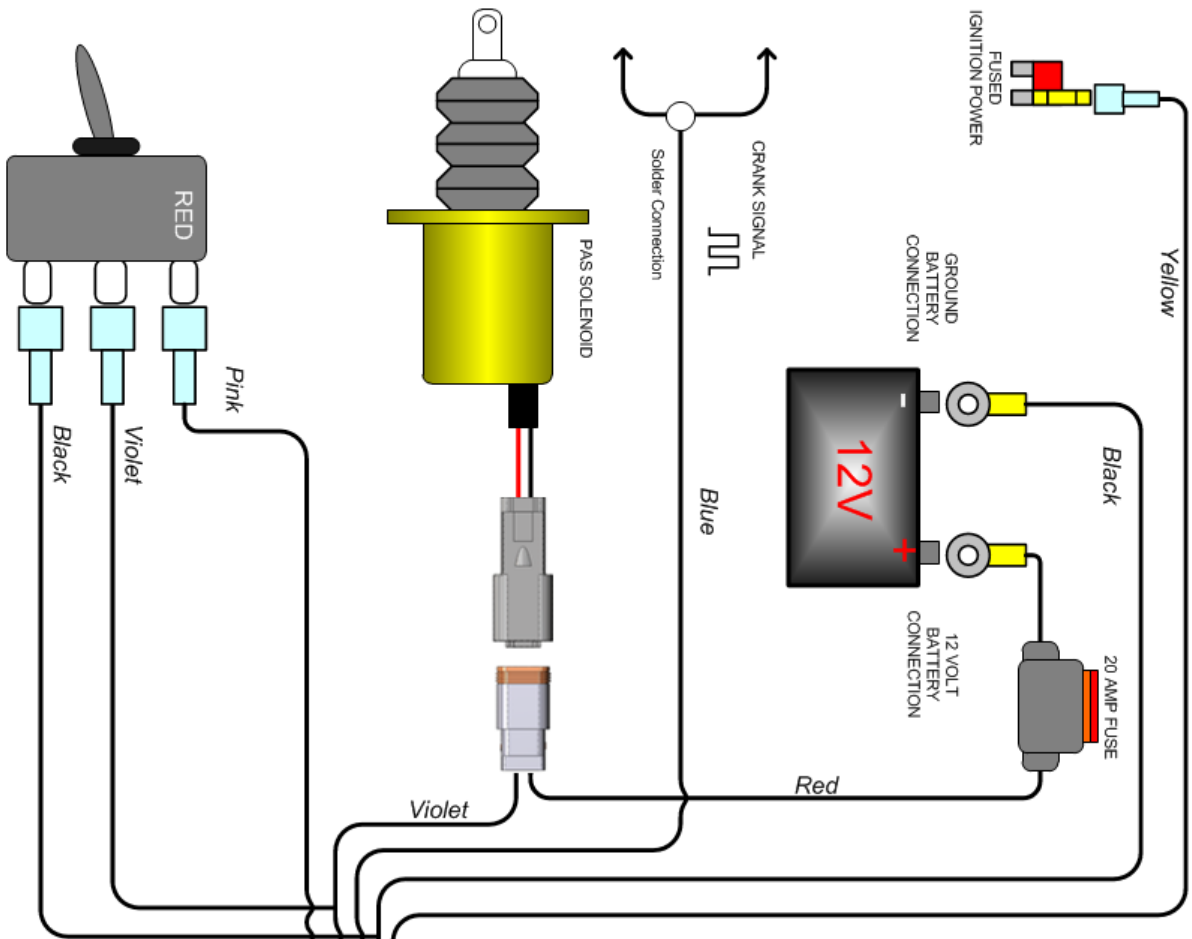

- POSITION 1 = Pre Programmed Automatic Mode (Vehicle Specific)
- POSITION 2 = Pre Programmed Test Mode
- POSITION 3 = Full Manual Mode (User must set)

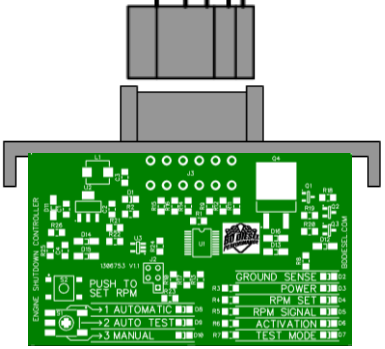

Application	Cutout RPM	Cutout Freq. (Hz)	Idle Freq. (Hz)
Dodge Cummins 1985-92	4200	4200	375
Dodge Cummins 2003-2013	5000	4800	675
Ford 6.7L Powerstroke	5000	5000	750
Ford 6.0L Powerstroke	4900	5000	750
Ford 7.3L Powerstroke	4900	880	150
Daimler 6.6L	4800	4800	750

WIRING DIAGRAM without OVER SPEED ELECTRONICS (1036701-M)

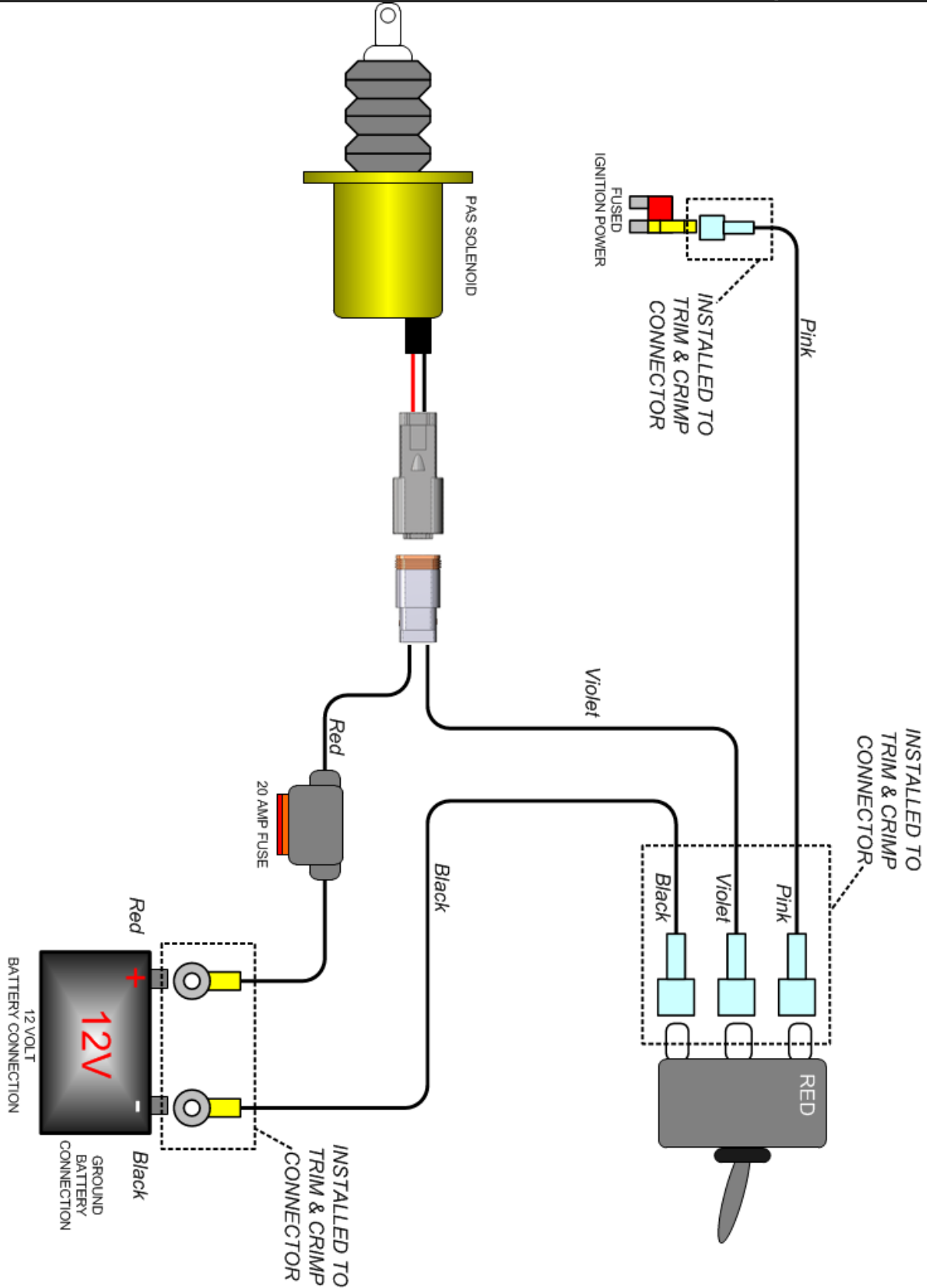

BD ENGINE BRAKE, INC.

Plant Address: A10-33733 King Rd, Abbotsford, BC, Canada V2S 7M9

US Shipping Address: 1124 Fir Avenue, Blaine, WA 98230 US Mailing Address: PO Box 231, Sumas, WA 98295

Phone: 604-853-6096 Fax: 604-853-8749 Internet: www.bddiesel.com

RESETTING THE VALVE

Valve Activated (Closed)

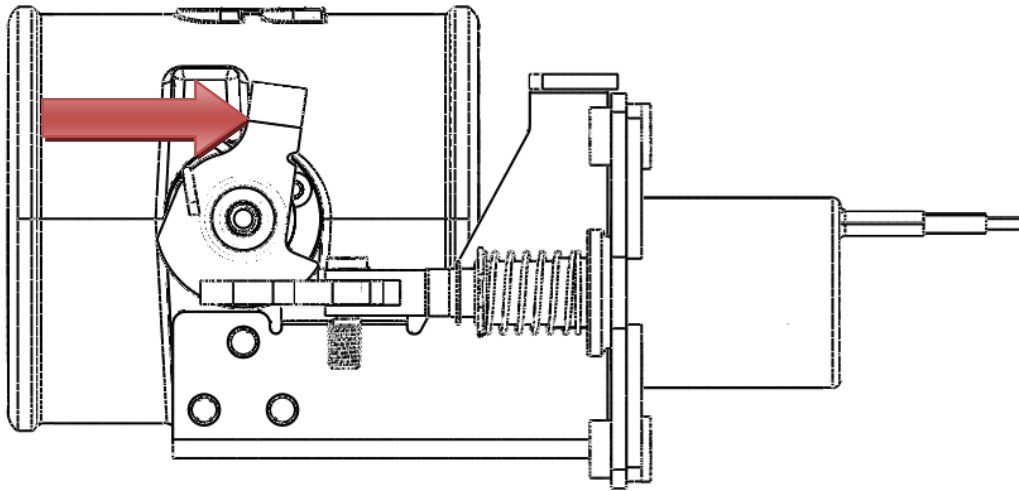

Valve Reset (Open)

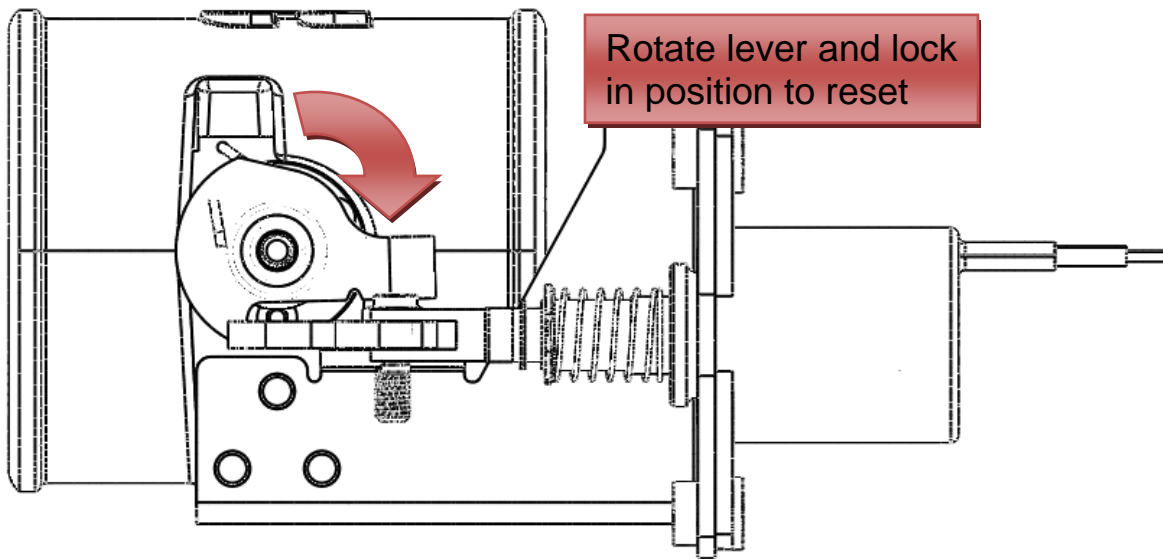

BD ENGINE BRAKE, INC.

Plant Address: A10-33733 King Rd, Abbotsford, BC, Canada V2S 7M9

US Shipping Address: 1124 Fir Avenue, Blaine, WA 98230 US Mailing Address: PO Box 231, Sumas, WA 98295

Phone: 604-853-6096 Fax: 604-853-8749 Internet: www.bddiesel.com

SETUP, TESTING AND VERIFICATION with OVER SPEED ELECTRONICS

Each unit is specifically configured for each model of truck. As in the case of different model years and makes the engine RPM frequency is different.	Engine Idle Speed Frequency
	2003-07 Ford 6.0L 600-800 Hz (1:1) ratio

2003-2007 Ford Powerstroke	Activation RPM	Activation Freq. (Hz)
PAS Switch Position #1 (Automatic Mode)	5000	5000
PAS Switch Position #2 (Test Mode)	1200	1200
PAS Switch Position #3 (Manual Mode)	User Configured	User Configured

Automatic Mode (Pre Configured RPM)	
Action	Failure/Fix/Notes
1. Start the engine. You should see the RED light illuminate on the toggle switch.	If the LED does not illuminate, check the wiring to the back of the switch first. Then check entire circuit.
2. With the engine idling, activate the toggle switch. You should hear the solenoid activate and the valve close. The engine should die. Once the engine dies the switch should flicker ON and OFF indicating a trip condition.	If the engine does not die, check to make sure the valve actuated. If the valve did not actuate check switch and ground wiring. If valve did actuate but the engine is still running, ensure nothing has contacted the valve mechanism
3. You can now reset the valve, by rotating the upper lever and engaging the solenoid stop.	

BD ENGINE BRAKE, INC.

Plant Address: A10-33733 King Rd, Abbotsford, BC, Canada V2S 7M9

US Shipping Address: 1124 Fir Avenue, Blaine, WA 98230 US Mailing Address: PO Box 231, Sumas, WA 98295

Phone: 604-853-6096 Fax: 604-853-8749 Internet: www.bddiesel.com

4. With the valve reset, remove the outer enclosure from the control module. There are two locking tabs on the sides of the enclosure.

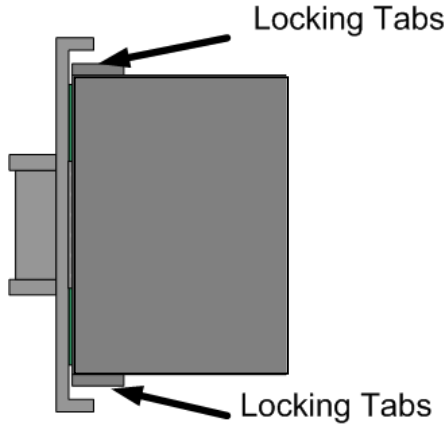

5. Change the position selection switch to position #2 (Auto Test). Slide enclosure cover over circuit board.

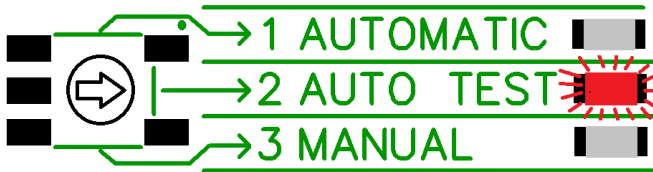
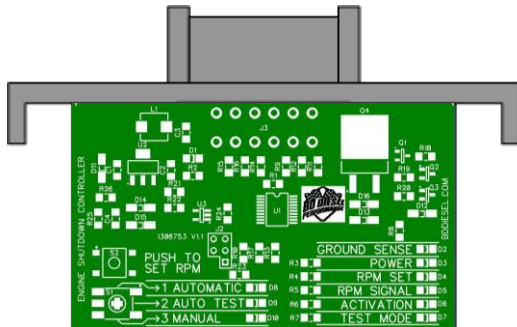

6. Start the vehicle, with the vehicle in park step on the throttle increasing the engine RPM. At 1200RPM the PAS should engage itself

If the engine did not stall, check to make sure the valve actuated. If the valve did not actuated, double check the engine RPM electrical

<p>automatically, and the engine should stall. Like with all activations the toggle switch should flash.</p>	<p>connection. Check the RPM Signal LED on the circuit board, it should flash proportionally to the engine RPM.</p>
<p>7. Reset the valve and reset the mode position switch to position #1</p>	
<p>You are now complete and the unit should function correctly. This test cycle should be completed once a year.</p>	

Manual Mode (User Configured RPM)

Setup

With the control unit, the user/installer has the ability to set their own activation RPM. It is necessary that you chose a low activation RPM first to test the units is operating correctly. Once it has, you will need to set the high limit RPM activation.

Note: When you press the Set button the module will add 25% to the set speed.

1. Open electronic enclosure, by releasing the two locking tabs on the side of the unit.

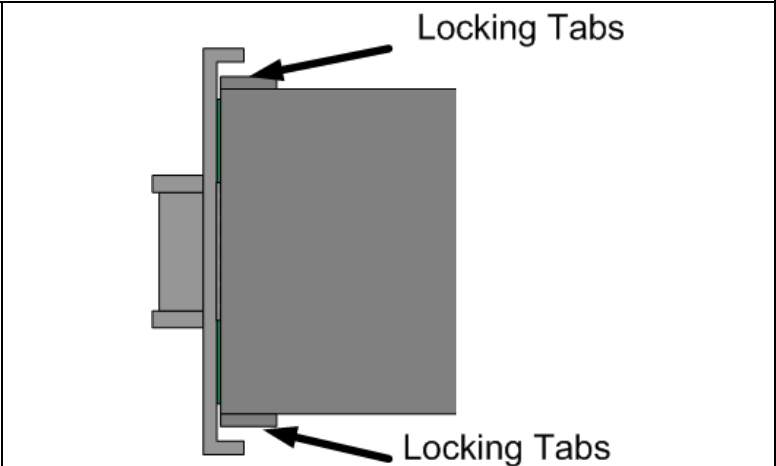

2. Adjust the position switch to Position #3.

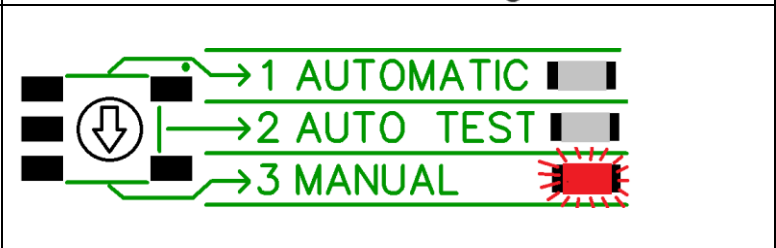

3. Start the engine.

4. Press and hold the RPM SET button.

When you push the SET RPM button will see the "RPM Set" LED illuminate.

5. With another person helping you, have them step on the accelerator with the vehicle in park. Raise the engine RPM to 1200 RPM.

6. Release the SET RPM button.

Upon releasing the button the unit will store the RPM + 25%. So for this example the unit has stored 1200RPM + 25% = 1500RPM.

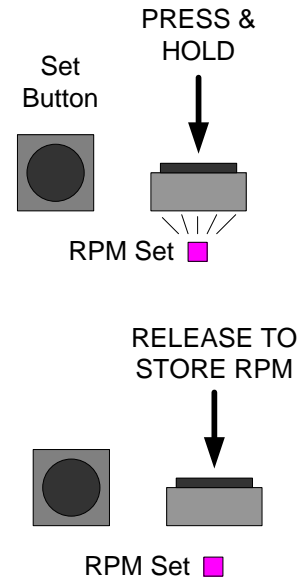

You should see the RPM signal flash proportionally to engine RPM.

7. Now increase the RPM of the engine to test the activation circuit is working correctly. As in this example the valve should activate at 1500RPM.

You should see the ACTIVATION LED flash ON/OFF on activation.

If the valve does not activate check the wiring.

If the valve activates but the engine does not stall, ensure nothing has contacted the valve linkage.

8. With the valve activated the engine should die. Reset the valve and restart the engine.

9. Press and hold the RPM SET button.

When you push the SET RPM button will see the "RPM Set" LED illuminate.

10. With another person helping you, have

BD ENGINE BRAKE, INC.

Plant Address: A10-33733 King Rd, Abbotsford, BC, Canada V2S 7M9

US Shipping Address: 1124 Fir Avenue, Blaine, WA 98230 US Mailing Address: PO Box 231, Sumas, WA 98295

Phone: 604-853-6096 Fax: 604-853-8749 Internet: www.bddiesel.com

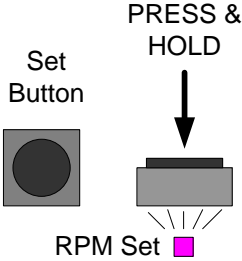
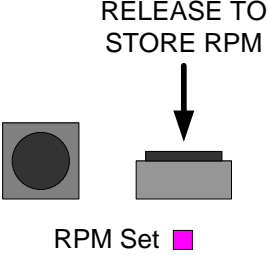
<p>them step on the accelerator with the vehicle in park. Raise the engine RPM to MAXIMUM engine RPM.</p> <p>11. Release the SET RPM button.</p> <p>Upon releasing the button the unit will store the RPM + 25%. So for this example the unit has stored MAXIMUM engine RPM + 25%.</p>	 
<p>12. You can now put the electronic enclosure back together and secure it the fuse box.</p>	
<p>13. With the engine running you will need to test to make sure the manual activation switch is functioning correctly.</p> <p>14. With the engine running, lift the activation switch and the engine should die.</p> <p>15. Reset the valve and you are now complete.</p>	<p>If valve does not activate check the wiring.</p> <p>If the valve activates and the engine does not die ensure nothing has contacted the linkage.</p>
<p>You are now complete the installation, please be sure to complete the test once a year to make sure the unit is functioning correctly.</p>	

TESTING FLOW CHART with OVER SPEED ELECTRONICS

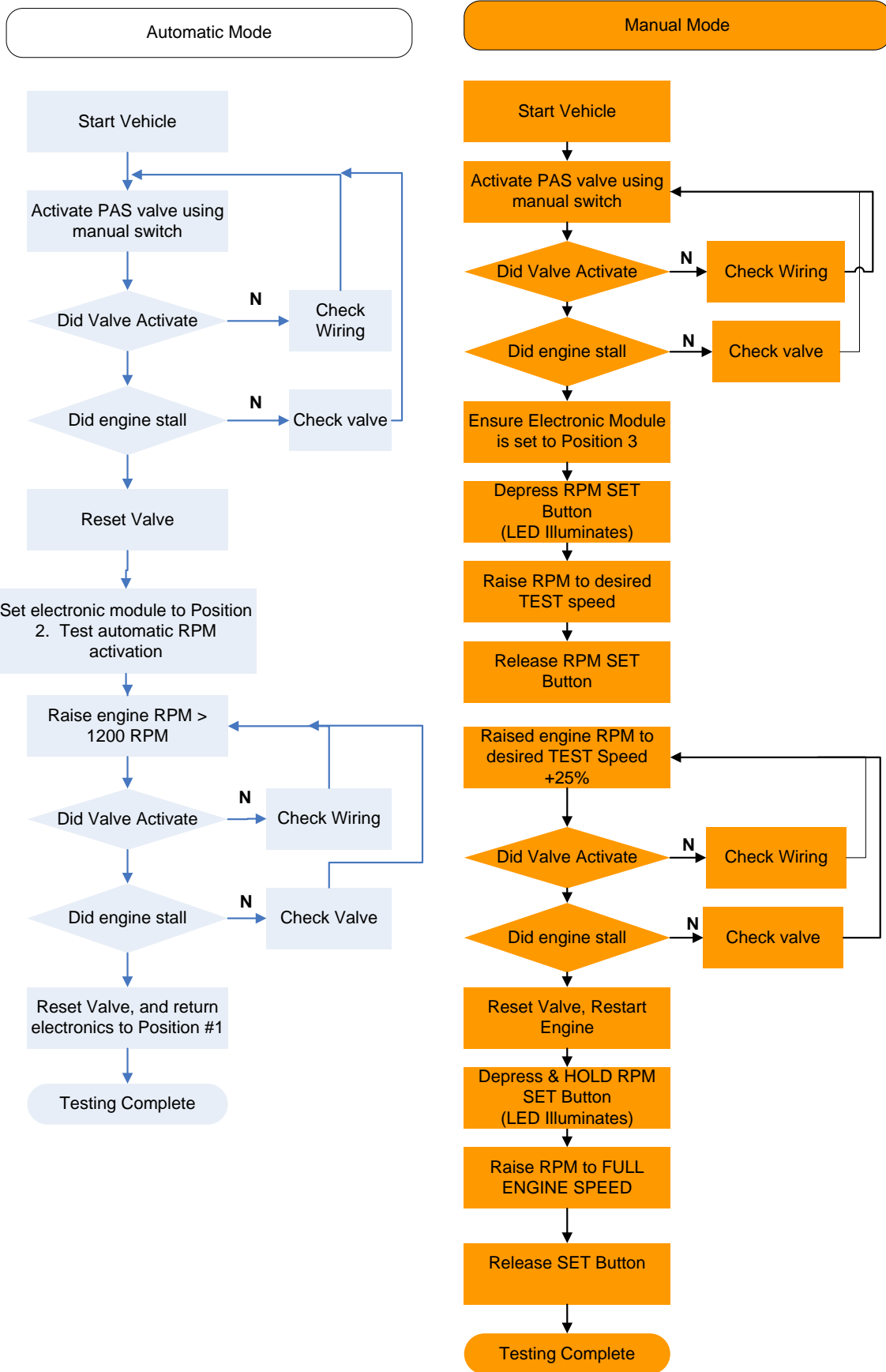

BD ENGINE BRAKE, INC.

Plant Address: A10-33733 King Rd, Abbotsford, BC, Canada V2S 7M9

US Shipping Address: 1124 Fir Avenue, Blaine, WA 98230 US Mailing Address: PO Box 231, Sumas, WA 98295

Phone: 604-853-6096 Fax: 604-853-8749 Internet: www.bddiesel.com

TESTING FLOW CHART *without OVER SPEED ELECTRONICS*

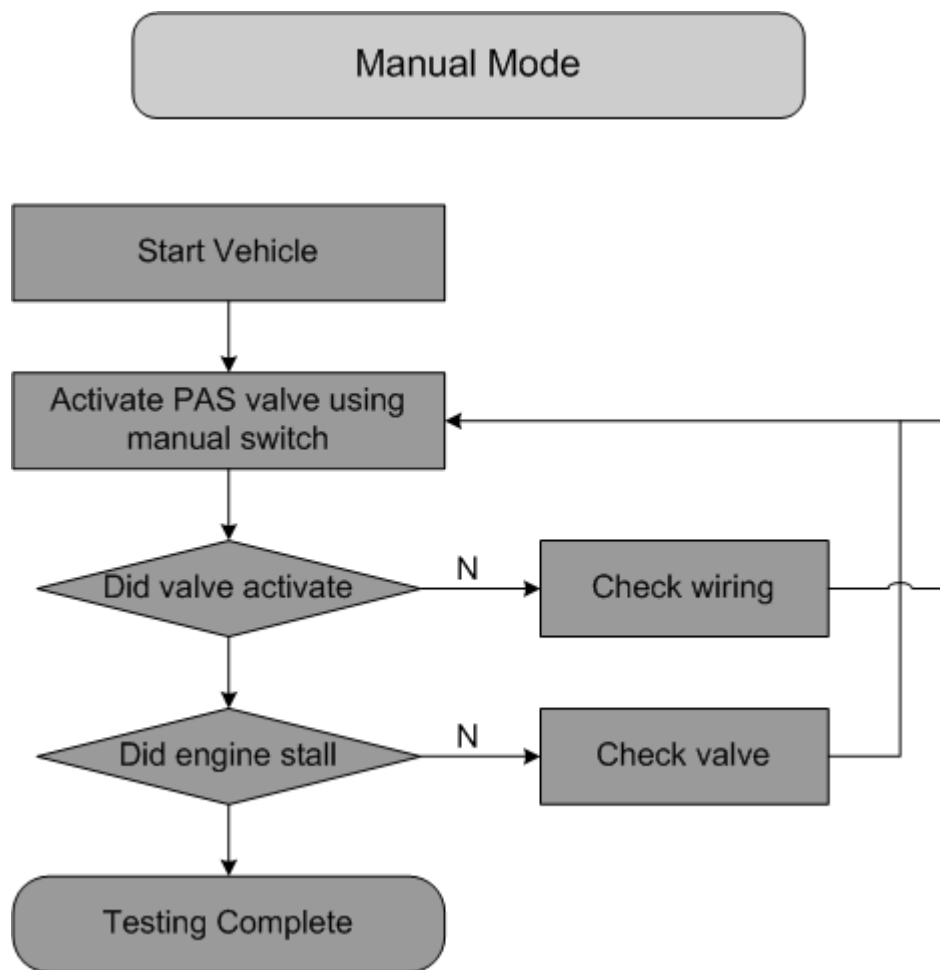

PCB LED Operation

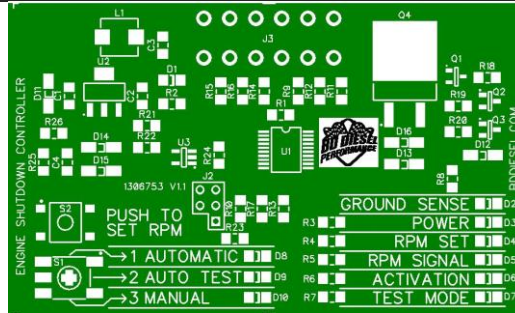

GROUND SENSE	Illuminates when PAS solenoid ground wire is grounded (activated). Normally off. Will light when shutdown switch triggered or module triggers the solenoid.
POWER	Illuminated when the module is powered (switched ignition).
RPM SET	Lights up while the SET RPM button is held down.
RPM SIGNAL	Flashes proportional to engine RPM signal.
ACTIVATION	Flashes when the PAS solenoid has been activated.
1 AUTOMATIC 2 AUTO TEST 3 MANUAL	These LEDs simply confirm the switch position.

If you have any technical difficulties, concerns, comments, or complaints, please phone our Technical Support hotline at (800) 887-5030 between 8:30am-5:00pm PST (Pacific Standard Time) Monday to Friday.

BD ENGINE BRAKE, INC.

Plant Address: A10-33733 King Rd, Abbotsford, BC, Canada V2S 7M9

US Shipping Address: 1124 Fir Avenue, Blaine, WA 98230 US Mailing Address: PO Box 231, Sumas, WA 98295

Phone: 604-853-6096 Fax: 604-853-8749 Internet: www.bddiesel.com