

# <THESE INSTRUCTIONS MUST BE GIVEN TO THE END USER>



**B&W Trailer Hitches**  
 1216 Hawaii Rd / PO Box 186  
 Humboldt, KS 66748  
 P:800.248.6564  
 F:620.869.9031

Call or Email us for  
 Installation Support  
 hitches@turnoverball.com  
 bwtrailerhitches.com

## Custom 5th Wheel Hitch Mounting Rail Installation Instructions

# MODEL 2600

2003-2012 Dodge RAM 2500 & 3500 Trucks

See Limited Lifetime Warranty at  
[bwtrailerhitches.com/warranty](http://bwtrailerhitches.com/warranty)

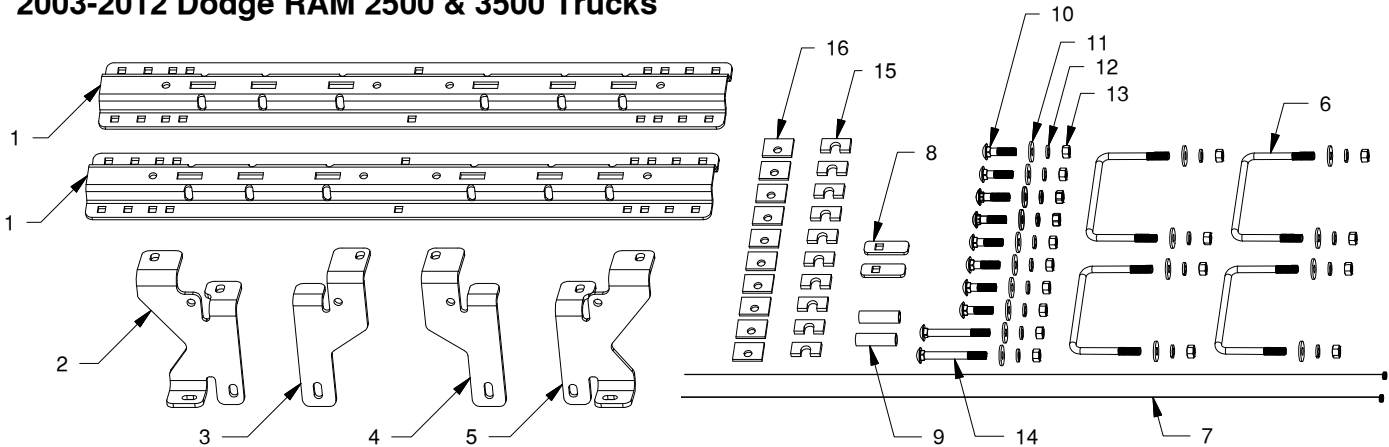

Patriot Rail Box (RVR3210)		
ITEM	DESCRIPTION	QTY
1	Mounting Rail	2

Bracket Set Box (RVR2600)		
ITEM	DESCRIPTION	QTY
2	Driver Side Rear Bracket	1
3	Passenger Side Front Bracket	1
4	Driver Side Front Bracket	1
5	Passenger Side Rear Bracket	1
6	1/2" X 6-3/4" X 4" U-Bolt	4
7	1/2 X 48" Fish Wire	2

Bracket Set Bolt Bag #1		
ITEM	DESCRIPTION	QTY
8	Locking Strap	2
9	Tube Spacer	2
10	1/2" X 2" Carriage Bolt	10
11	1/2" Flat Washer	20
12	1/2" Split Lockwasher	20
13	1/2" Finish Nut	20
14	1/2" X 4-1/2" Carriage Bolt	2

Bracket Set Bolt Bag #2		
ITEM	DESCRIPTION	QTY
15	5/16" U-Shaped Spacer	10
16	Offset Rectangle Washer	10

## **⚠ WARNING** Failure to comply with the safety information in these instructions could result in serious injury or death.

- ⚠** Read all installation and operating instructions along with all labels before using this product.
- ⚠** Adding components to the chassis of any vehicle can be hazardous. There is potential for damage to vehicle, injury from tool usage and many other hazards. This installation must be completed by someone who is aware of the hazards involved. This person must be knowledgeable of proper safety procedures for a vehicle installation of this nature, and for usage of the equipment required to perform the installation.
- ⚠** Without proper knowledge, towing can be a dangerous activity. Understand all the risks involved with towing before proceeding. For information on towing safety, see **"The Trailer Handbook: A guide to Understanding Trailer and Towing Safety"** from the **National Association of Trailer Manufacturers**, [www.NATM.com](http://www.NATM.com) and your trailer manufacturer's owner's manual.
- ⚠** Do not exceed tow or tongue rating of coupler, tow or tongue rating of hitch, or tow or weight ratings of truck or trailer. See vehicle and trailer manufacturer information for ratings. Exceeding these ratings may cause damage to towing components or loss of attachment between the trailer and truck.
- ⚠** Additional caution must be used when towing a wedge car trailer. Towing stability greatly depends on keeping the center of gravity as low as possible. Load heavy cars over the axles. Never tow with a single car on the front of the trailer. When towing a wedge car trailer, never exceed speeds that are reasonable for the roadway conditions (e.g. turns, going around a curve, etc.). Failure to account for proper trailer center of gravity and speeds that are reasonable for the roadway conditions may cause damage to the truck, trailer, towing components, and loss of attachment between the truck and trailer.
- ⚠** Do not modify this product in any manner. Doing so could alter its integrity and lead to a loss of attachment between the trailer and the tow vehicle.
- ⚠** Regularly check that all bolted connections are at the correct torque specification. A visual inspection should be performed before each time you tow.

# PREPARING TO INSTALL

**NOTICE:** It may be necessary to remove the spare tire and/or heat shield before installation.

**NOTICE:** If truck is equipped with a removable bed liner or mat, it should be removed or it must be cut to allow the mounting rails to connect directly with the bed. It is acceptable to install the mounting rails over a spray in bed liner.

**NOTE:** Remove all parts from the packaging and familiarize yourself with all the parts and tools required. Use the parts list on the front page to verify that all parts and hardware are present.

**⚠ WARNING:** Do not install frame brackets or U-bolts over wiring or brake lines. Always place the hitch components directly against the frame of the truck. Failure to move such components can lead to property damage or serious injury.

Installation of the mounting rails requires several common tools and a few specialized tools. Below is a listing of equipment used during a typical installation.

- Impact wrench or ratchet with a 3/4" socket
- 3/4" box end wrench
- A drill and 1/8", 9/16" and 7/8" Drill bits
- Patriot 5th wheel or Slider Base
- Hammer
- Flashlight
- Tape Measure
- Eye Protection
- Ear Protection
- Torque Wrench
- Center Punch Tool

## DRILL REAR MOUNTING HOLES

1. **Layout the rear mounting rail.** Place a mounting rail onto the bed of the truck. Hook a tape measure over the rear edge of the bed (not on any part of the tailgate), measure the location for the mounting rail as shown in Figure A1. Next, center the mounting rail in the bed by measuring the distance on either side from the edge of the rail to the sides of the bed. The rail will be centered when both measurements on either side of the rail are the same.

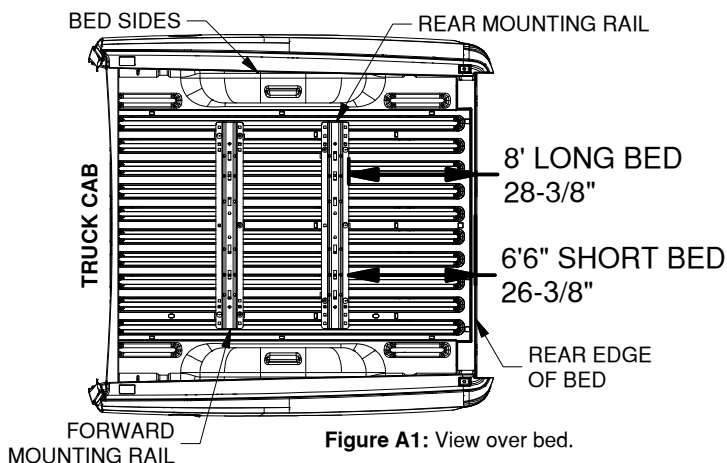

Figure A1: View over bed.

**IMPORTANT:** The mounting rail is designed to install only at the described location. Failure to place the mounting rail precisely may result in added difficulty during installation and/or property damage.

2. **Mark hole locations.** While carefully ensuring the mounting rail does not move, use a center punch tool to mark the 5 drill locations on the rear rail. See Figure A2 for hole marking locations for this installation (forward rails will install on a later step). Once all 5 rear rail locations are clearly marked, move the bed rail out of the way and drill each location with an 1/8" drill.

**NOTE:** The two forward drill locations on the rear rail are directly above a bed cross member. The drill must pass through both the bed and the cross member and should be as straight as possible when drilled.

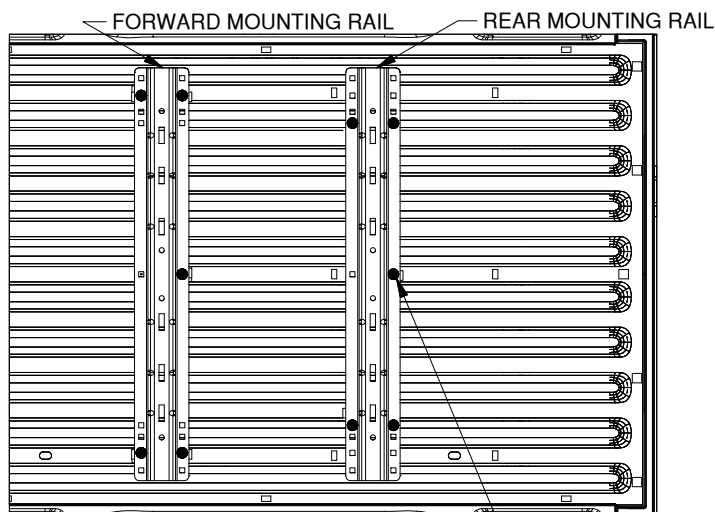

Figure A2: Detail view over bed, showing drill locations for the forward and rear bed rails. DRILL LOCATIONS HIGHLIGHTED BY BLACK DOTS

- ⚠ WARNING:** The fuel tank of the truck may be directly below the area of the bed which needs to be drilled. Always carefully examine the area under the truck where modification will occur. Make certain that the tank, or other equipment, is not damaged during drilling. Damage to the tank may result in property damage, serious injury or death.

3. **Check hole locations.** Locate the driver side rear frame bracket and a U-bolt. Position and hold the bracket flat against the inside of the frame where it will be installed, see Figure A3. Pass the U-bolt from the outside of the frame through the corresponding holes in the bracket. Check that the 1/8" pilot holes are centered within the slots in the frame brackets. If the 1/8" drilled holes are not centered within the slots, re-drill the 1/8" holes until the brackets and the drilled holes are aligned. Repeat the process for the passenger side using the passenger side rear bracket and a U-bolt, see Figure A4.

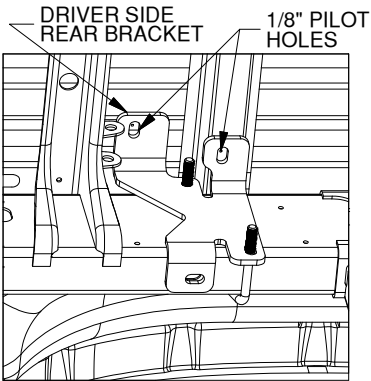

Figure A3: View looking up at the inside of driver side frame.

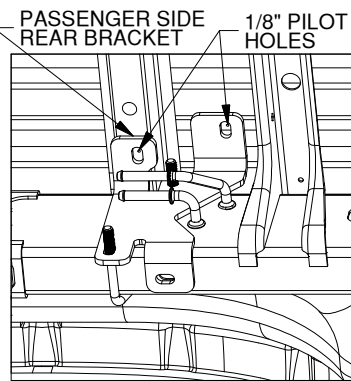

Figure A4: View looking up at the inside of passenger side frame.

4. **Enlarge the holes.** The 1/8" holes will be used as pilots on top of the bed. With a 9/16" drill bit, carefully drill the five rear mounting rail holes, drill through both the bed and the cross member for the two forward holes. Use 7/8" drill bit to enlarge the two holes positioned above the cross member. Only enlarge the 7/8" holes in the bed and avoid drilling through the bed cross member, as shown in Figure A5.

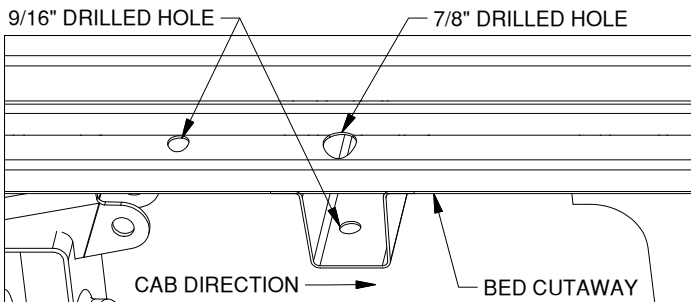

Figure A5: Cutaway view looking at top of driver side bed.

## INSTALL REAR MOUNTING RAIL

**NOTICE:** Due to the corrugation of the truck bed, U-shaped spacers are provided to function as space fillers between the mounting rails and the kit attachment hardware. Always place a U-shaped spacer in the gap either above the bed (between the mounting rail and the bed) or below the bed (between the bed and the side mounting brackets). Failure to use U-shaped spacers will result in property damage when hardware is tightened.

1. **Install the rear mounting rail.** Place the two tube spacers into the the 7/8" holes. Re-position the rear mounting rail over the drilled holes in the bed. Install two 1/2" X 4 1/2" carriage bolts into the two forward drilled positions (holes over the cross member) and install three 1/2" X 2" carriage bolts through the three rear drilled positions, as shown in Figure B1. Place U-shaped spacers between the bed and the mounting rail. Two spacers (as near as possible) by the 4-1/2" carriage bolts, and one spacer around middle carriage bolt.

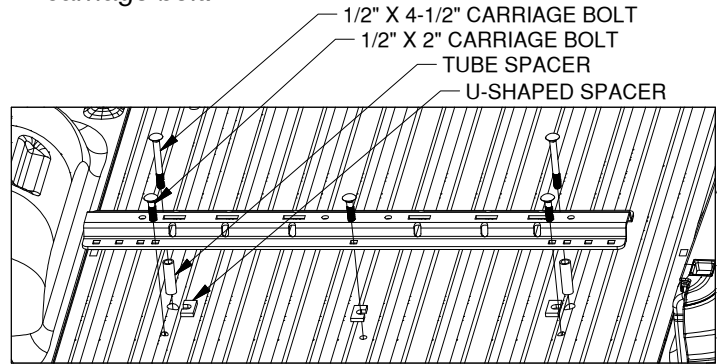

Figure B1: View looking into truck bed from rear of truck.

2. **Install frame carriage bolt.** The installation of the frame brackets requires a 1/2" x 2" carriage bolt to be installed inside the frame. First, locate two 1/2" x 2" carriage bolts, two locking straps, and the two fish wires. Locate the 1-1/2" hole in the bottom of the frame; it is located roughly 14 inches from the end of the frame. The hole in which the carriage bolt will be installed is forward of the 1-1/2" hole another 14 inches. Start by attaching a carriage bolt onto a fish wire, as shown in Figure B2. Next, position a locking strap into the 1-1/2" hole and thread the fish wire through the square hole in the locking strap and into the frame, see Figure B3. Continue to feed the fish wire into the frame until it becomes visible through the forward hole. Retrieve the end of the fish wire through the forward hole. Push the locking strap completely into the frame, see Figure B4. Pull the fish wire and pass the carriage bolt into the frame. Pull the end of the fish wire and maneuver the carriage bolt into the square hole in the locking strap. Pull the carriage bolt out through the frame and remove the fish wire. Repeat this process for both sides of the frame.

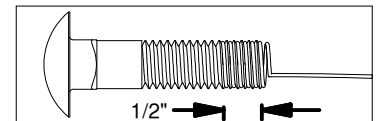
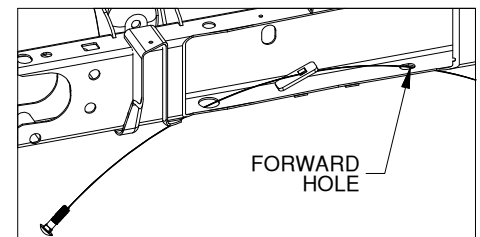
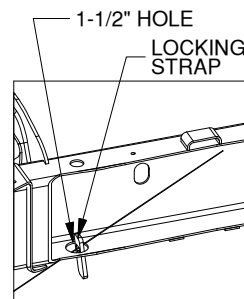

Figure B2



Figures B3 & B4: Cutaway view of the inside of the driver side frame.

3. **Install the rear frame brackets.** Position each rear frame bracket as described in "Check hole locations" step in the last section. Place a U-shaped spacer around the carriage bolt passed down through the bed as the frame brackets are lifted into place. Fasten the U-bolts and carriage bolt (under the frame) to the rear brackets with three 1/2" flat washers, 1/2" lock washers, and 1/2" finish nuts, see Figures B5 and B6. Install an offset rectangle washer, 1/2" flat washer, 1/2" lock washer and 1/2" nut on each of the carriage bolts passing down through the bed, as shown in Figure B7. Hand tighten each nut.

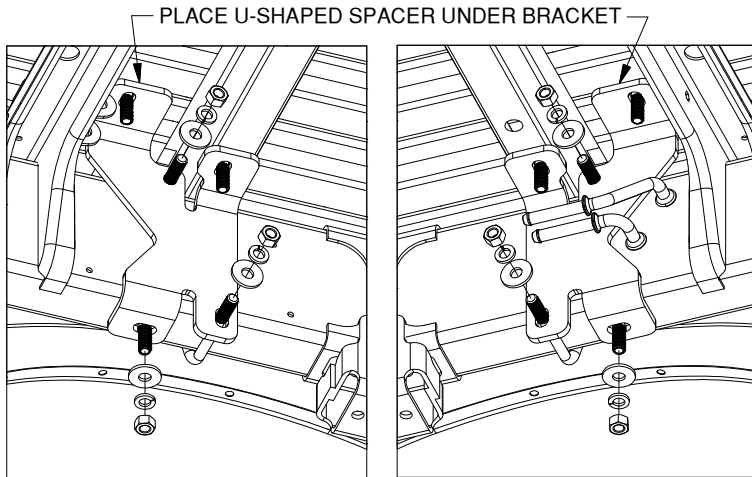

FIGURE B5: View looking up at the inside of driver side frame.

FIGURE B6: View looking up at the inside of passenger side frame.

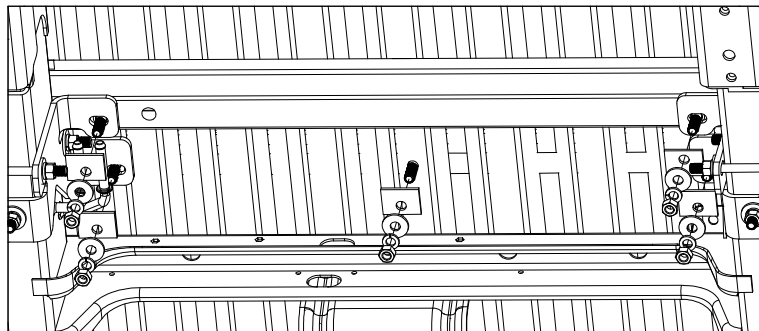

FIGURE B7: View looking up at the bottom of the truck bed.

## INSTALL FORWARD MOUNTING RAIL

1. **Position the forward mounting rail.** For this step the base which will be used in the mounting rails is required. Place a mounting rail into the truck bed in front of the rear mounting rail. Place the base over the rail attachment points and carefully lower it until the pin tabs pass through the attachment points on the rear mounting rail. Attach the forward mounting rail to the forward mounting points on the base. The base should rest flat against the top of the rails, see Figure C1. With the base still attached ensure that the forward rail is centered in the truck bed.

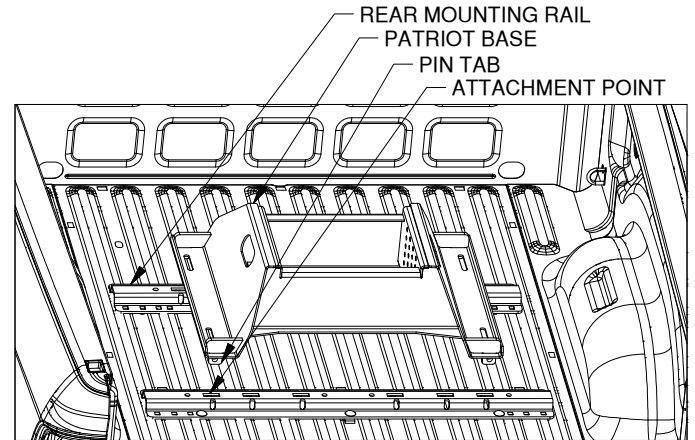

Figure C1: View into truck bed looking toward tailgate.

2. **IMPORTANT:** Before drilling forward mounting holes pull the RV base toward the rear of the truck and push the forward rail toward the cab of the truck to correctly space the mounting rails, see Figure C2.

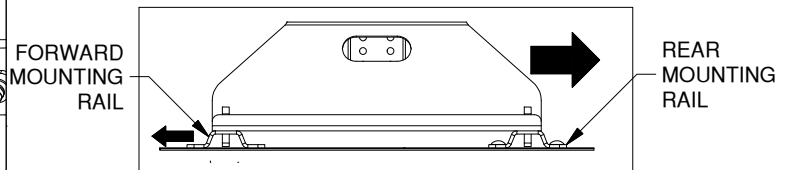

Figure C2: Side view of RV base and mounting rails.

3. **Drill forward mounting holes.** Using the same methods as used for the rear mounting rail, mark and drill the 1/8" holes for the forward mounting rail. Refer to "DRILL REAR MOUNTING HOLES" section, Step 2, on a previous page. Notice that the hole locations are slightly different than the rear rail, see Figure A2 (on the second page).
4. **Enlarge the holes.** Remove the base and move the forward rail out of the way. Use the 1/8" holes as pilots, and drill out each hole with a 9/16" bit.

4. **Install the forward mounting rail.** Re-position the forward mounting rail over the drilled 9/16" holes in the bed. Install five 1/2" X 2" carriage bolts through the five drilled positions, as shown in Figure C3. Place a U-shaped spacer between the bed and the mounting rail at the five drilled positions.

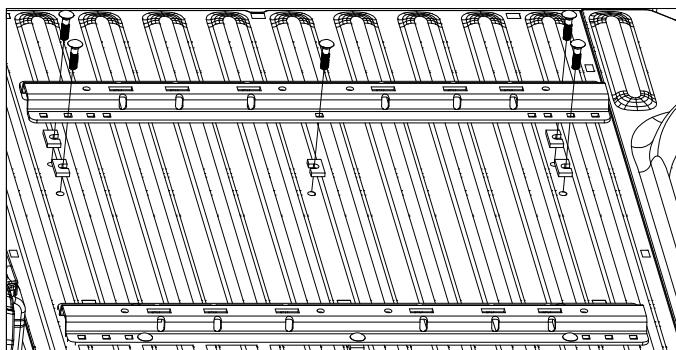

Figure C3: View looking into truck bed from rear of truck.

5. **Install front brackets.** Locate the driver side front bracket, a U-bolt, two 1/2" x 2" carriage bolts, 1/2" flat washers, 1/2" lock washers and 1/2" finish nuts. Position the bracket behind the cross member under the installation location of the forward mounting rail. Maneuver the bracket so that the 1/2" carriage bolt passes through the slot at the top of the bracket as shown in Figure C4. While holding the bracket flat against the outside of the frame pass the U-bolt over the frame and through the bracket and secure with 1/2" hardware, see Figure C5. Repeat for passenger side. Hand tighten each nut.

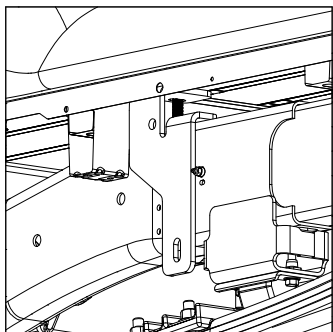

Figure C4: View looking at outside of driver side frame.

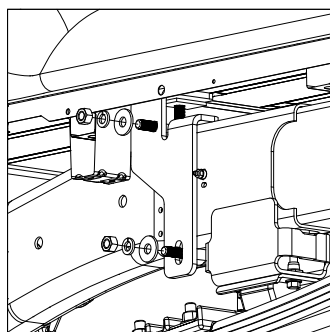

Figure C5: View looking at outside of driver side frame.

6. **Place front rail hardware.** Under the bed install an offset square washer, 1/2" flat washers, 1/2" lock washers and 1/2" finish nuts on each of the carriage bolts, see Figure C6. Hand tighten each nut.

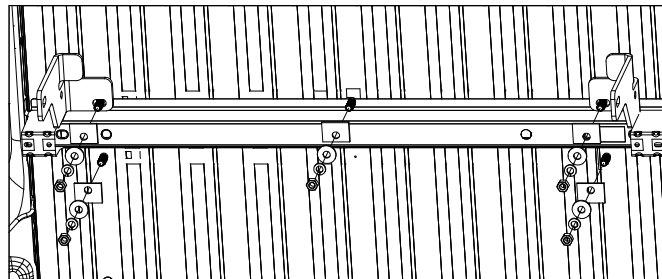

Figure C6: View under bed looking up. (Frame not shown)

7. **Tighten hardware.** Using a torque wrench, first torque all the 1/2" nuts in the mounting rails to 80 ft-lbs. Second, torque all 1/2" nuts in the frame brackets to 80 ft-lbs.
8. **Secure frame elements.** If any wiring was moved or detached during installation, check that it has been re-secured to the frame. Reinstall the heat shield and spare tire if necessary.