



DEDENBEAR®

L-STS STEPPER THROTTLE STOP SYSTEM INSTALLATION & OPERATION MANUAL

		INDEX		
Installation Instructions.....	pg 1		Starting Line Control / Super Start	pg 6
Pro/Full Feature.....	pg 2		Wiring/Power/Troubleshooting/Skip Button.....	pg 7-8
Button Use & Programming.....	pg 2-3		Throttle Stop & Nitrous Wiring	pg 8
Types of Delay Boxes	pg 3		Linkage Stop & Remote Display	pg 9
Setting Transbrake Delay.....	pg 3-4		Timed Shifter Wiring	pg 10
Setting Throttle Stop Types & Timers.....	pg 4-5		Stepper Stop/ Setting Parameters	pg 11-12
Throttle Stop Control	pg 5			

STEPPER THROTTLE STOP SYSTEM OVERVIEW

DEDENBEAR STSK IS INTENDED FOR USE ON 555CID ENGINES OR SMALLER, COMPRESSION RATIO OF 14.5:1 OR LESS, AND CARBURETORS WITH 2.125" BORE SIZE OR LESS. WHEN UNIT IS FIRST POWERED UP, THE TRANSBRAKE SWITCH INPUT MUST BE CYCLED BEFORE BACK-UP BUTTON IS USED.

Thank you for purchasing the new L-STS Stepper Throttle Stop Delay Box. This delay box, by itself contains all of the features and functions as the current Lightning and Lightning Plus delay boxes. It provides 4 modes of delay (Delay, Interface, Crosstalk, and Crossover) as well as two 4 stage timers. These timers can be configured to run throttle stops, linkage stops, shifters and nitrous oxide systems that are either electric or CO2 powered. The main new feature of the new L-STS Stepper Throttle Stop System is its ability to control the new STS-7 Base Plate Throttle Stop. This base plate stop, when coupled with the L-STS, gives you unmatched control of the throttle stop position.

What can the stepper throttle stop system do that CO2 and electric stops can't?

- Move to any position between closed and full open – 100 different positions.
- Move to different positions during the same run.
- Move at varying rates, even during the same movement.
- Is not affected by CO2 pressure, varied voltage (12 to 16 volts), temperature, etc...
- Repeatable to within 1/20th of a degree and one one-thousandth of a second – every time.
- 8 movements/stages of the stepper throttle stop.
- Pre-stage with different modes and varying positions.

The next question is: why would I want these features?

Electric stops are good because they are very consistent. They move nearly the same every time as the only variation is the change of the magnetic field and the pull strength of the spring – two things that don't change much over time, temperature, etc... Electric stops, however, only give you 1 position and one rate – fast. You risk spinning your tires when the stop re-opens and you can't control the movement rate.

CO2 stops solved the tire spin issue by allowing one to slow the bleed rate through a needle valve. This allowed the racer to control movement rate of the throttle STOP BLADES to allow a smooth transition back into wide open throttle and helped control wheel spin. CO2 has the major disadvantage of being inconsistent. CO2 is a gas and its qualities vary with temperature, pressure, system volume, flow rate, etc... If you change any of the following parameters, the performance of your system will be affected:

- Change the volume of your CO2 plumbing (add a new system or change the line length)
- Replace your line with new, un-aged line that has stiffer walls
- CO2 gas temperature variations (hot vs. cold day, car in the sun, hot engine compartment, etc...)
- CO2 bottle full vs. low – affects regulator fill rate.
- Barometric pressure affects needle valve performance.
- Debris, dirt, etc... in needle valves, actuators, etc...
- Temperature of the CO2 actuators affects sealing grease viscosity and movement rate.
- Carburetor throttle position has a large affect on the aerodynamic load on the throttle STOPBlades, affecting the movement rate of the blades, as does barometric pressure and air density.

By combining several CO2 cylinders (or electrical actuators) some racers have been able to develop stops that were capable of moving to two different positions at differing rates. This gave the racer the ability to launch on one stop position, transition to another stop position, and then open both. These resulted in complex systems that were more prone to failure.

The Stepper Stop solves all of these issues.

- First, it is very consistent. It is digitally controlled and will be in the same position every time, whether moving from one position to another or holding still. It is not affected by varied battery voltage as 12 to 16 volts are available. It is not affected by temperature, carburetor throttle position, CO2 bottle pressure, air density, etc.
- Second, it can move at varying rates. It has 9 different movement rates – anywhere from 40° per second to 1,100° per second. This equates to full travel in anywhere from .08 to 2 seconds-full closed to full open. This allows you to select how fast the throttle stop opens or closes to optimize how fast your engine transitions from low to high and back to low power.

- Third, the stop can STOP AT any of 100 positions from full closed to full open. This allows you to tune your car to launch at a desired RPM, close the throttle stop to limit your ET, then re-open to a nearly full open position allowing you to override with your skip switch to regain full power to run down your opponent.
- It also will allow some racers to do away with their linkage stop, two step and other starting line aids as the Stepper Throttle Stop can provide the racer with a new set of options that enhance the performance of the vehicle with one component as opposed to several.

Setup of the Stepper Throttle Stop is relatively straight-forward, but requires some forethought before jumping in. It is a new technology that must be understood before you are ready to install & race with it. Follow the instructions carefully.

INSTALLATION

Using #8 screws through the rubber grommets in the base, mount the **L-STTS** away from heat, vibration and the ignition system. Make sure the driver can reach the buttons when strapped in and angle the unit, if needed, so the display can be read straight on. Wire the **L-STTS** as shown on pages 7-10. Make sure the power lead comes straight from the master switch and the ground goes to a solid chassis ground, not sheet metal pan.

QUICK BUTTON REFERENCE

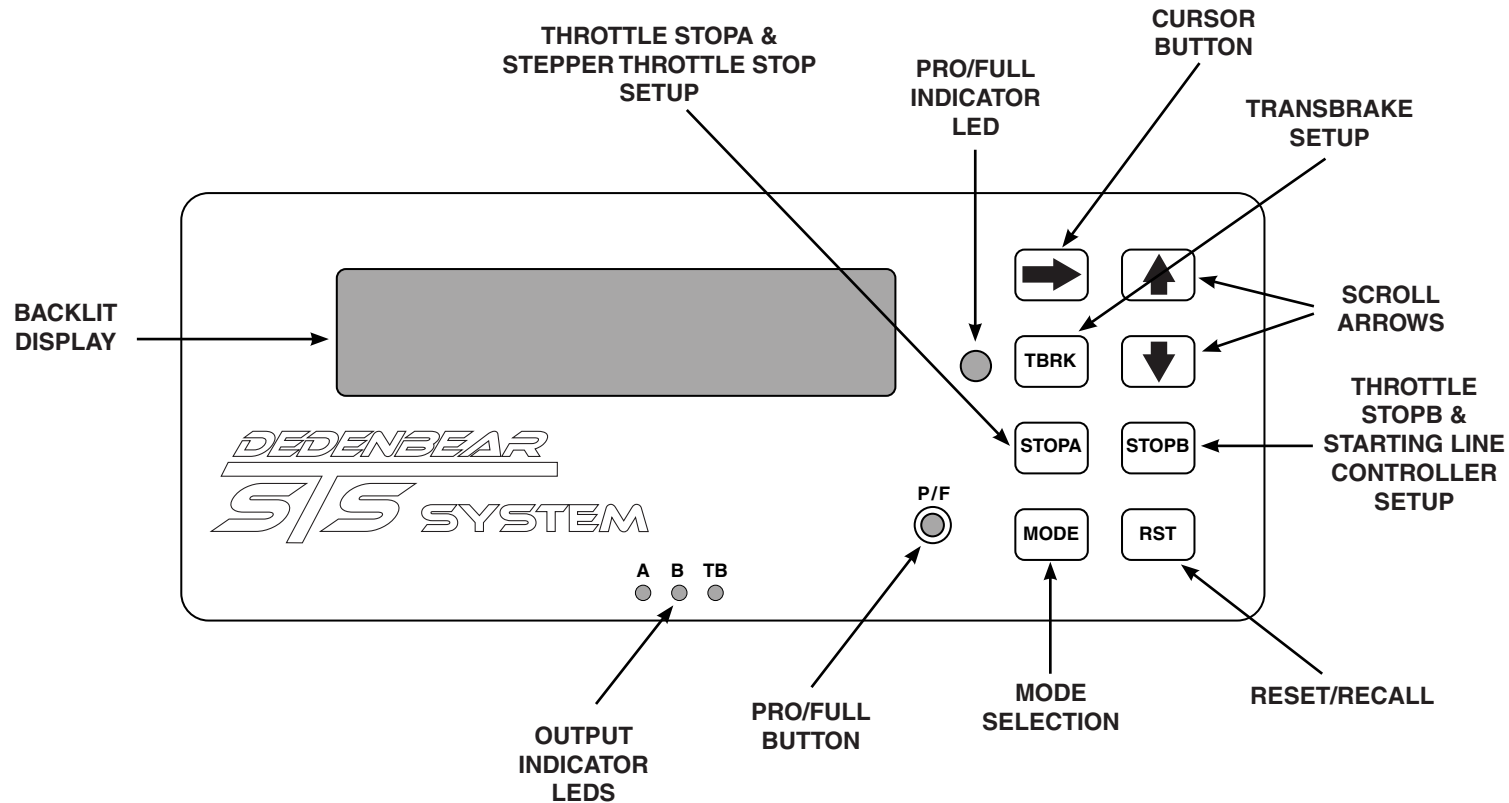

BUTTON USE & SETTINGS

The **L-STTS** has many selections that can be programmed for each setting. Each time you push the button for the particular setting you are adjusting, it will step you to the next prompt screen. The **L-STTS** will only ask for the settings needed for the particular mode you are in. For example, when adjusting settings for throttle STOPA, the **L-STTS** will not ask for the settings for your transbrake delay. At each prompt screen you can change a setting by using the scroll buttons or the cursor. If no adjustment is needed for a setting, press the button again to step to the next screen. After your adjustments are made, the **L-STTS** automatically returns to the run mode after 8 seconds.

PRO/FULL BUTTON

The **L-STTS's** PRO/FULL feature allows you to switch between two complete setting groups for the delay box and throttle stop features. This enables you to program the box for your "Super" class settings in **PRO**, and then program your bracket race settings in **FULL**. Now when you switch between classes, you no longer need to reprogram the **L-STTS**, just push and hold the **PRO/FULL**

button to switch between groups of settings. The red LED indicator light to the left side of the keypad will indicate which setting group you are in. When you are in the **PRO** group, the **PRO/FULL LED** will turn on and stay on. When you are in the **FULL** group, the **LED** will be off.

P/F



REMEMBER: It is extremely important when you change a setting that you are in the setting group (PRO or FULL) in which you want the change to occur since each group has it's own complete set of settings.

PROGRAMMING BUTTONS



Arrow (scroll) Buttons: These buttons are used for making small changes to your settings. You can add to a setting by pressing the up arrow, or subtract with the down. If you push and hold an arrow key, the setting will continue to change faster and faster.



Cursor Button: This button allows you to change each digit individually. This makes large number changes much quicker than just using the scroll. When you push the cursor button the first time, a cursor appears under the left most digit. Each press of the cursor button thereafter moves the cursor one digit to the right. Stop the cursor under the digit you wish to change and use the arrow (scroll) buttons to change that digit up or down. Pressing the cursor button one more time after the cursor is under the right most digit will remove the cursor from the screen and return the arrow buttons to regular scrolling action.

On pages with multiple settings – the Stepper Stop Menus-keep pressing the cursor button to move on to each of the settings available on that page.



TBRK Button: This button accesses your Transbrake settings. Each time you press the TBRK button, different set-up screens come up & allow you to make changes to your Delay, Delay 2, your ET, their ET, Bottom Delay, Cross Comp, Skip Up/Down, TB Pause, & TB Lockout settings.



STOPA Button: This button accesses your Stepper Throttle Stop settings or your Throttle Stop Controller A settings. Each time you press the STOPA button, different set-up screens come up and allow you to make changes to your Stepper Throttle Stop settings or your 4 Timer setting (time A1 to A4.)



STOPB Button: This button accesses your Throttle Stop settings or your Starting Line Controller settings. Each time you press the STOPB button, different set-up screens come up and allow you to make changes to your Throttle Stop settings or your 4 Timer setting (time B1 to B4.)



MODE Button: This button selects which of the 4 delay box modes you wish to run; Delay, Crossover, Interface or Cross Talk.



RSET Button: Reset/Recall Button: This button is used for setting the box for the type of equipment it will be running, i.e., Throttle Stop Type, Starting Line Control, etc. Press and hold the RSET button to make the change. This button also can be used to cancel the throttle stop timers during the pass and recalls information about the run after the pass has been made.

DELAY BOX TYPES

The **L-STTS** has four different types of delay boxes built in. They are:

1. **DELAY:** A simple delay box used for pro tree classes and leaving off your top amber for full tree classes. The box simply delays for the time set and releases the transbrake.
2. **CROSSOVER:** Used in full tree bracket racing for launching off your opponents top bulb when you are the faster car. The box calculates the handicap and adds it to your delay time.
3. **INTERFACE:** This is used the same as crossover except it allows you to take two hits at the tree. You leave off the opponent's top bulb, press the transbrake button again, then release off your own top bulb. The box will release the transbrake on the quicker of the two releases. This means if your release on the opponent's top bulb gives you a .520 light and the release on your top bulb gives you a .505 light, the box will launch the car on the .505 light. Remember, the interface always chooses the quicker light and will choose a .490 over a .500.
4. **CROSS TALK:** Used for the cross talk bracket tree, this mode functions the same as the Interface mode except it allows you to take two hits at your tree, one off your top amber, and one off your second amber. Like the Interface, the box will choose the quicker of the two reaction times. To change between the delay box types, press the MODE button. Continue until the mode you want appears.

SETTING TRANSBRAKE DELAY

To set your transbrake delay you must first choose which delay box type you wish to run by pressing the MODE button. The **L-STTS** will only ask for the settings required for that particular mode.

Example: When you are in RUN (DELAY) it will not ask you for THEIR ET setting since you are not crossing over. All of the shared settings between these modes will transfer when you change to a different mode. Example: Your delay setting will transfer over to all four different delay box modes along with your SKIP, TB PAUSE, and TB LOCK OUT settings.

THEIR ET YOUR ET DELAY

RUN 9.00 1.00
INTERFACE 10.00

RUN SCREEN: This is the screen the **L-STTS** will display when it is “ready to run”. It will always display **your** ET and **your** DELAY. When in Crossover, Interface and Cross Talk modes it will also display **their** ET.

NOTE: If you are not using the remote display dial-in board (part# RD-1) the YOUR ET setting is not important when in the DELAY mode. This setting will not effect your delay time.

TBRK

Press the **TBRK** button to enter the transbrake adjust settings menu. Each time you press this button it will advance to the next set-up screen. Once you have advanced through all of the screens, the box returns back to run mode. When you are through making adjustments to the settings, the box will automatically return to the run mode in 8 seconds.

SETUP MODE
DELAY 1.000

DELAY: When you first press the TBRK button, the delay setting will appear. Use the scroll arrows or the cursor button to change this setting. For leaving off the top bulb on a full tree, this setting is typically around 1.000 second.

SETUP MODE
DELAY2 .500

DELAY2: This screen will appear next only in Cross Talk mode (not needed in Delay, Crossover or Interface). Delay 2 is the amount of delay used for taking a 2nd hit at the 2nd amber bulb on a Cross Talk bracket tree. Typical 2nd amber delay setting is around .500 second. Use the scroll arrows or cursor button to change this setting.

SETUP MODE
THEIR ET 10.00

THEIR ET: This is the next screen that will appear in Interface, Crossover and Cross Talk modes (not needed in Delay mode). Use the scroll arrows or cursor button to change this setting to your opponent’s dial-in.

SETUP MODE
YOUR ET 09.00

YOUR ET: This is where you enter your own vehicle’s dial-in. Use the scroll arrows or cursor button to make changes. If you run a Remote Display dial-in board, this is the setting that will be displayed upon return to run mode.

SETUP MODE
BOT DELAY 100

BOT DELAY: Bottom bulb delay time is the amount of delay you need for a bottom bulb release on a full tree when using the “Last Chance” feature while in Interface and Cross Talk modes. Adjust with scroll or cursor button.

SETUP MODE
CROSS COMP .015

CROSS COMP: Crossover compensation time is used to compensate for late lights when crossing over. When you cross over and leave off your opponent’s tree, you get an indirect view of his top bulb instead of a direct view like on your side. This results in a reaction time that is about .010 to .020 seconds slower. Crossover compensation automatically subtracts this time from your delay setting whenever you crossover. Use the scroll arrows or cursor button to change this setting. **NOTE: Cross comp should be set for 0.000 when running on a Cross Talk bracket tree.**

SETUP MODE
SKIP DOWN -015

SKIP DOWN or SKIP UP: This is the amount of time you want to add (Skip UP) or subtract (Skip Down) from your delay time after you have released the transbrake button. If you feel you “missed” the tree, every time you push the skip button the box will add or subtract this amount from your delay time. Use the scroll arrows to change this setting.

SETUP MODE
TB PAUSE 100

TB PAUSE: This is the amount of time the box pauses from when the transbrake button is depressed until the transbrake sets. This prevents transbrake application if the button is accidentally bumped or brushed while driving down the return road or in the staging lanes.

SETUP MODE
TB LOCKOUT 03

TB LOCKOUT: This is the amount of time the box will lock out the transbrake so the driver can not re-apply the transbrake during the pass. Use the scroll arrows or cursor button to change the lock out in increments of whole seconds.

NOT USING A STEPPER STOP

STOP A TYPE
STEPPER STOP

If you are not going to be using a Stepper Throttle Stop with the L-STTS delay box, you need to configure STOPA to a baseplate (non-stepper) or linkage style stop. This is done by pressing the STOPA button until you get to the STOPA TYPE: screen as shown below.

Press and hold RSET until the type of stop that you are using is selected – See page 10 for further instruction on setting up this type of stop.

THROTTLE STOP STEPPER SCREEN

STOP A TYPE
STEPPER STOP

This screen is used to configure your L-STTS to the types of stops that you have connected. Press and hold the RESET button while this screen is up to change from “BASE PLATE STYLE” to “LINKAGE / DISC” to “STEPPER STOP”. The difference between “BASE PLATE STYLE” and “LINKAGE / DISC” is the polarity of the output signal. “BASE PLATE STYLE” will turn power off at timer 1 and turn power back on at timer 2. “LINKAGE / DISC” will turn power on at timer 1 and turn power off at timer 2.

- Under the carb “Butterfly” throttle stops use BASE PLATE STYLE
- Under the carb “Disc” throttle stops use LINKAGE / DISC
- In-line linkage stops use LINKAGE / DISC
- Nitrous Oxide systems use LINKAGE / DISC
- Dedenbear Solenoid Shifter Hold type use BASE PLATE STYLE
- CO2 or “Air” shifters us: LINKAGE / DISC

CONVENTIONAL SETUP SCREEN

T STOP B
TIME 1: 1.000

The conventional setup screen will be active when a conventional stop is used. Use the scroll arrows or the cursor button to make changes to the actuation time of the timer. All timing for the timers starts at the release of the TransBrake solenoid. So, if you had 1.000 in timer 1, 2.000 in timer 2, 3.000 in timer 3 and 3.000 in timer 4, the car would launch with the stop not actuated for 1.000 seconds, the timer would actuate at 1.000 seconds until 2.000 seconds, then de-actuate and remain open for the remainder of the run. Timer 3 and timer 4 cancel out each other as they are set for the same time. Effectively, timer 3 is called, but prior to re-actuating the stop, timer 4 is called to de-actuate the stop. Please note that all timers are adjustable to the thousandth of a second, unlike the L1 and L2.

THROTTLE STOP TIMERS

The **L-STTS** has 2 separate throttle stop controller outputs, the STOPA / Stepper and the STOPB / SLC output. The STOPA output functions as either simply a timer or as the Stepper Throttle Stop controller, while STOPB output is both a timer and a starting line control (SLC). Both outputs work independently from one another allowing control over two separate devices. The STOPA output can be used either to run the Stepper Throttle Stop or as a 2 or 4-stage timer. The STOPB / SLC output can be used as a 2 or 4 stage timer and / or a starting line control. It can be used as a combined 2 or 4-stage timer and starting line output for using the same throttle stop for starting line control and down track use. To use the STOPB / SLC output for down track timing only (no starting line control) you must turn the start line control setting to Off. See page 6 for details. Either of the throttle stop outputs can be used to time just about any 12 volt device. Besides throttle stops, common uses are timed shifts, nitrous systems, ignition retards, lean outs, etc. The STOPA and STOPB / SLC outputs are rated at 15 amps each.

STOPA STOPB

To set your throttle stop timers, press the STOPA or STOPB button to enter each of the respective timer menus. Each time you press the button it will advance to the next set-up screen. The procedure is the same for changing settings as in the TBRK menu. After advancing through all the screens, or after 8 seconds without making a change, the box returns to run mode.

A1: 0100
A2: 1100

Summary Screen

The first screen that will be displayed is a summary screen that shows you the throttle stop timer setting for quick reference. 2 stages will be displayed at a time. If the Throttle Stop Control is turned OFF, no summary screen will be displayed. Note that the timers are preceded with a letter. A1 represents STOPA, timer 1. B3 represents STOPB, timer 3. Like all other prompt screens, this screen will disappear and return to run mode after 8 seconds.

A3: 2.500
A4: 2.550 ERROR

Each of the timer values must be greater than or equal to the preceding timer value. A2 must be greater than or equal to A1 & A3 must be greater than or equal to A2, etc... If two timers are set to the same time on conventional stops, neither will have an effect and will cancel each other out. With the Stepper Throttle Stop, the L-STTS computes the time it takes for the Stop to move from one position to the next. This is dependant on how far it must move (how many steps) and how fast you programmed the movement to be (rate.) If you set another movement to occur prior to the completion of the previous move, an error will be displayed on this page as shown to the left for A4. A4 is programmed to occur too soon after A3. If there is an error in the way a set of timers is configured, you will get a STOPA SET WRONG or STOPB SET WRONG displayed on the run screen notifying you that you should correct the error.

NUMBER OF STAGES SCREEN

Reset/Recall Button: Used to change the settings for the type of equipment on your car. For example, the type of throttle stop, how you want the starting line controller set up, etc. To use it for these applications, go to the set-up screen for the feature you wish to change, press & hold the RSET button until the box changes its set up. If pressed during a pass, the RSET button will cancel the throttle stop timers & return to a ready to run condition. If pressed after the run, the RSET button will recall the “How Late” information and how many times you “Skipped”.

ARP (Accidental Release Protection): Occasionally you may anticipate the lights & release the button too early. ARP lets you recover from this situation. In Delay and Crossover modes, you simply press the transbrake button again before the car launches & the **L-STTS** will instantly reset itself. In Interface & Cross Talk modes this does not work because the **L-STTS** is

NUMBER OF STAGES SCREEN cont,

expecting a second hit. To avoid a red light you can use the Last Chance feature.

Last Chance: This feature works only in Interface and Cross Talk modes. If you think either or both of your releases were too quick, press the transbrake button down a third time to cancel the first two hits, then release the button off your bottom bulb to launch the car. If your car red lights off the bottom bulb, add some time to the Bottom Bulb delay and the Last Chance feature will use the delay from that setting.

How Late: In the Interface and Cross Talk modes where you can take two hits at the tree, the How Late feature tells you which of the hits was faster and by how much. In Interface mode the How Late timer will display "THEIR TREE .XXX" or "YOUR TREE .XXX" or "LAST CHANCE ACTIVATED". As an example, if you were in Cross Talk mode, the display might read "FIRST HIT .023". This means that you were quicker leaving off your top bulb than your second bulb and that you were .023 seconds quicker. The **L-STs** released the transbrake off the top bulb hit in this example. If you had cancelled the first two hits by pressing the button a third time, the display would read "LAST CHANCE ACTIVATED". After a run is made, the How Late information is recalled by pressing and holding the RSET button. The display will show both the How Late information and the number of Skips.

Skip Recall: Skip Recall tells you the number of times you pressed the Skip button during the delay box time out. By checking the set up menu you can determine how much time each Skip was & whether it added or subtracted time to the delay setting. By multiplying the Skip time by the number of Skips, you can calculate the total amount of time that was added or subtracted from your delay time. The number of Skips used can be recalled after the run by pressing & holding the RSET button. The display will show both the How Late information and the number of Skips.

Throttle Stop Settings Incorrect: If a throttle stop timer is accidentally set lower than the preceding set timers (timer 2 set lower than timer 1 or timer 3 set lower than timer 2, etc.) this message will appear. Change the timers to correct the problem. If the run is made without fixing the problem, the affected timer will not execute the conflicting timers. If STOPA is configured as a Stepper Stop, it will execute the Stages in order and as early as as commanded. Correct the error condition as the results may not be as expected

Dial-ins Incorrect: If the Their E.T. setting is accidentally set lower than Your E.T. this message will be displayed. If you make a pass without fixing the problem, the **L-STs** will assume the handicap is zero and will only use the delay setting.

Line Lock Output: The Line Lock Output is exactly the same as the Transbrake Output except that it is diode protected. This means that if wired in (see page 7) the delay box will operate the line lock on the starting line, but the line lock will not back feed to the transbrake solenoid while doing a burnout.

Leaving Set Up Menus, Four Ways To Leave:

1. Do nothing and the unit will return to the run mode automatically after 8 seconds.
2. Press the Transbrake button and the unit will instantly return to run mode.
3. Clock through the set up menu by repeatedly pushing the setting button until you get back to run mode.
4. Change set up modes (i.e. in the Transbrake set up, you can press the STOPA button and jump directly to the set up menu for STOPA, etc.)

Memory: The microprocessor in the **L-STs** will remember all of your settings, even after turning off the power. There are no internal batteries to die, so the unit will keep your last settings forever.

Battery Chargers: It is important to make sure to have your master disconnect switch off while hooking up your charger between rounds. When the first contact is made between the charger and the battery there may be a voltage spike that could damage electronics. After the charger is hooked up, the master switch can be turned back on to run the water pump, fan, etc.

Temperature: If the **L-STs** ever gets over 140° F, the display will get dark and unreadable. This does not damage the unit, simply cool it off and the display will return to normal.

STARTING LINE CONTROL & SUPER START SYSTEM

STOPB

Starting Line Control (SLC) is a shared output with STOPB. This output can be used to control a single throttle STOPAs a down track stop to control the E.T., a starting line control to control the staging RPM, or both. To use the STOPB / SLC output as just a starting line control, simply change the STOPB CONTROL setting to OFF. To use the STOPB / SLC output as just a down track control, simply change the START LINE CONTROL setting to OFF.

The starting line control settings are accessed through the STOPA menu. There are 4 different SLC options(see below for individual descriptions). This output is wired to a linkage style throttle stop to control your staging RPM in various ways. Press & hold the RSET button to flip through these options.

The Super Start System is a feature that allows you to activate your Starting Line Control BEFORE you stage the vehicle by momentarily pressing the skip switch allowing you to stage with your foot on the floor. The optional skip switch must be wired in to use this feature. The Super Start works differently in each of the SLC modes, see below for specific functions.

START LINE CNTRL TBRAKE RELEASE

SLC Transbrake Release functions as follows: At application of the transbrake (when you press the transbrake button) the linkage stop will close your throttle. At transbrake solenoid release (launch) the linkage stop will pull the throttle wide open. If you wish, the Super Start can be used in this mode also. Momentarily press the Skip Button prior to staging the car and the linkage stop will close right then so you can stage the car with your foot on the floor. The linkage stop will still pull wide open at transbrake release.

START LINE CNTRL TIMED 1.000

SLC Timed functions as follows: At application of the transbrake (when you press the transbrake button) the linkage stop will close your throttle. At the predetermined time (whatever is set in this set-up screen) BEFORE transbrake solenoid release (launch) the linkage stop will pull the throttle wide open. Using this feature will allow you to have the car come up against the converter or 2-step for exactly the same amount of time every pass whether you are crossing over or launching off your tree. If you wish, the Super Start can be used in this mode also. Momentarily press the Skip Button prior to staging the car and the linkage stop will close right then so you can stage the car with your foot on the floor. The linkage stop will still pull wide open at the predetermined time before transbrake release.

START LINE CNTRL PRESTAGE

SLC Prestage functions as follows: In this mode you must activate the Super Start System prior to staging by momentarily pressing the Skip Button to have the linkage stop close your throttle. At activation of the transbrake solenoid (when you press the transbrake button) the throttle will immediately pull to wide open so the motor will come up against the converter or 2-step for the entire staging duration. This mode is primarily used in pro-tree classes with short staging durations but it can be used with a full tree if desired.

START LINE CNTRL TURNED OFF

SLC Turned Off: If you wish to run without the aid of your Starting Line Control you can simply turn the output off. In this mode the SLC will do nothing. The off setting is also used when the STOPA / SLC output terminal is to be used to control a down track throttle stop only.

WIRING THE POWER FEED, TRANSBRAKE BUTTON & SKIP BUTTON

1. Wire the 12v power supply wire directly to the master on-off switch at the back of the car. Use at least 10 gauge wire. Do not wire the power supply to the starter solenoid, Ford style solenoid, switch panels or existing fuse blocks. Install a 15 amp fuse or circuit breaker to protect the **L-STs** from short circuits.
2. Install a 14 gauge wire from the ground terminal to a solid chassis ground, do not use the same ground that the ignition box uses and do not use aluminum or sheet metal panels as these are not reliable grounds.
3. Wire the transbrake solenoid directly to the Transbrake terminal using 14 gauge wire.
4. If you are going to use a rev limiter on the starting line, tie the rev limiter activation wire in with the transbrake wire.
5. Run a 14 gauge wire from the **L-STs**'s +12 volt terminal to one side of the transbrake button used to launch the car. Run the other side of the button back to the TB Switch terminal on the **L-STs**. If the button is mounted on the steering wheel, make sure the stretch cord is at least 14 gauge wire.
6. If you wish to use the optional Skip button, supply power to one side of the button from the **L-STs**'s +12 volt terminal using 18 gauge wire. Run a wire from the other side of the skip button to the Skip Switch terminal on the **L-STs** using 18 gauge wire.
7. If you wish to use the optional line lock output on the **L-STs** to simultaneously hold the line lock and transbrake on the starting line, run a 14 gauge wire from the Line Lock terminal on the **L-STs** to the line lock solenoid.

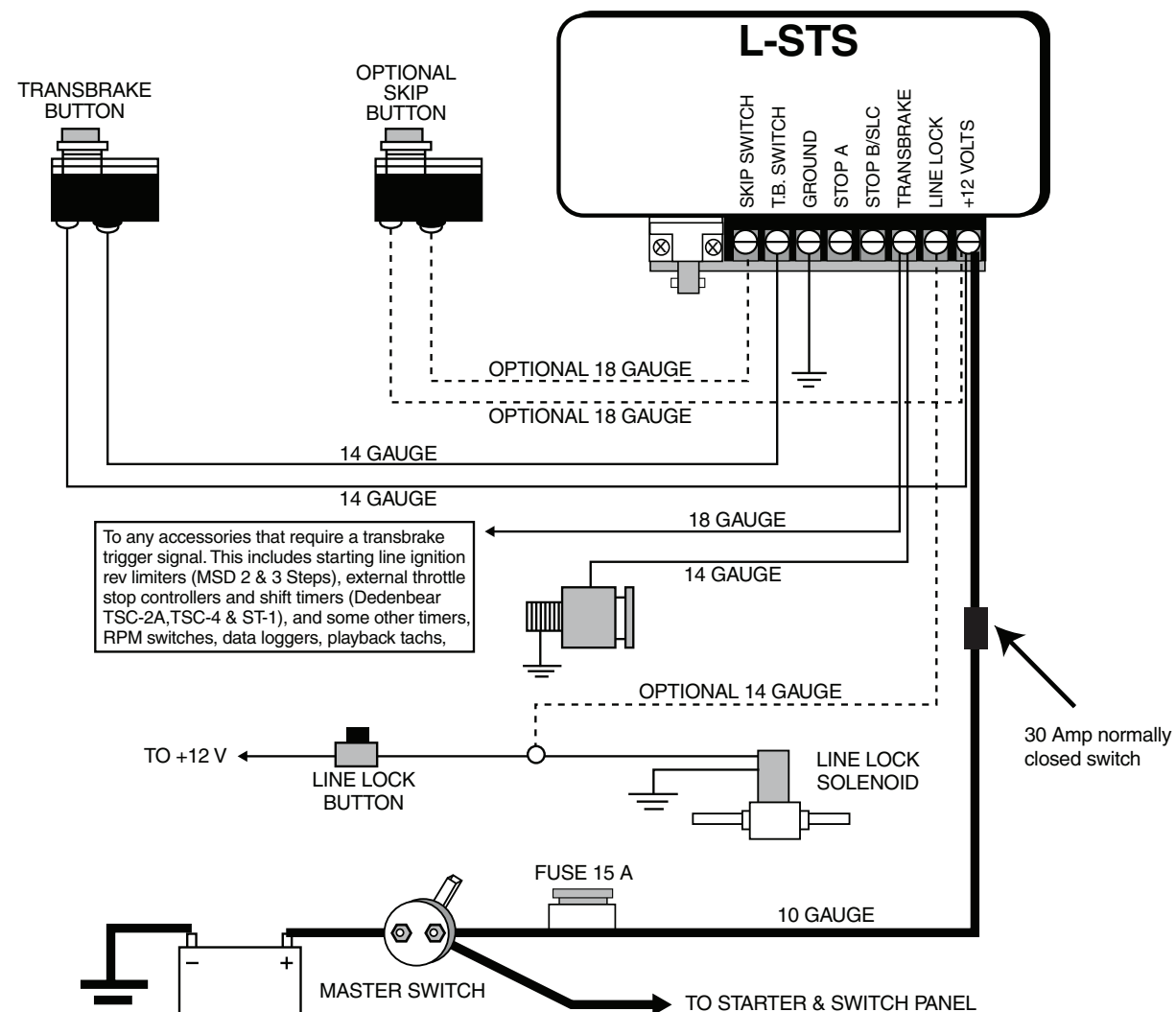

WIRING FOR BASEPLATE STYLE THROTTLE STOP

For electric "butterfly" throttle stops, set Stop A or B to "BASEPLATE TYPE".

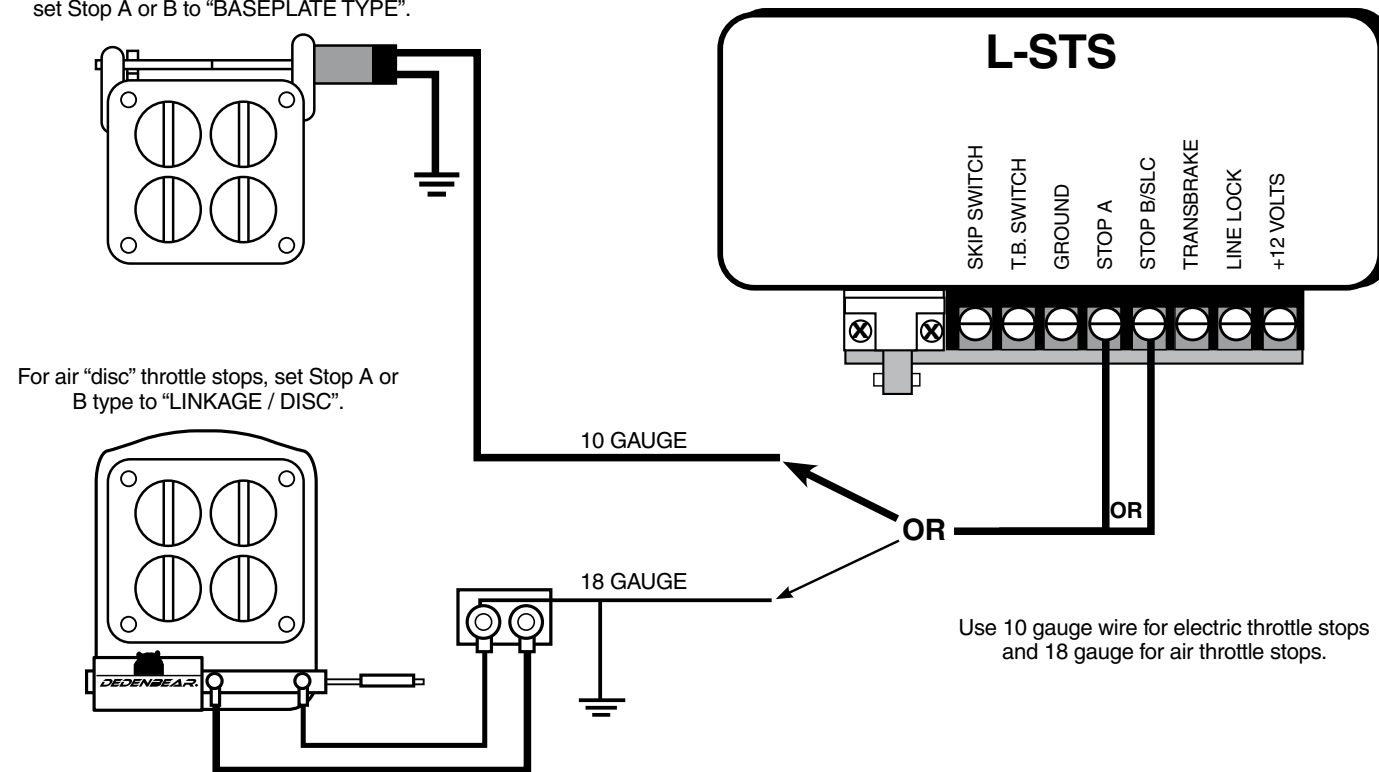

WIRING FOR 2-STAGE NITROUS SYSTEM

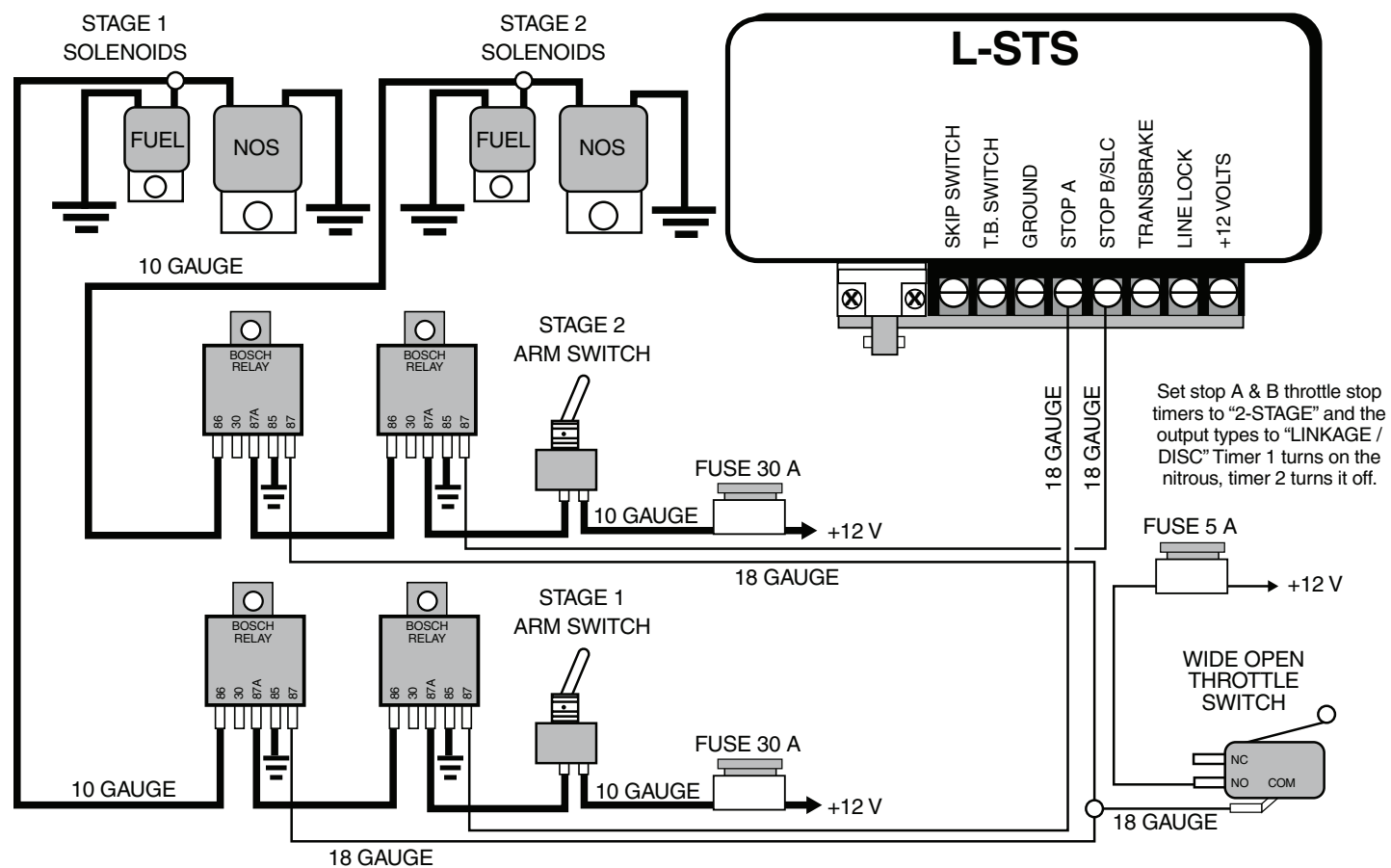

WIRING FOR LINKAGE STYLE THROTTLE STOP

There are 3 different ways to use a linkage style throttle stop. They are wired the same.

1. Starting Line Control: In this application the linkage stop closes on the starting line when the transbrake is applied (or prior to staging if the pre-stage feature is activated). This is to control the staging RPM of the engine. See page 6 for a complete description of starting line control options. To use the STOPB/SLC output only as a Starting Line Control, turn the T-STOPA Control to OFF (see page 5).
2. Down Track E.T. Control: In this application the linkage stop is used only during the pass to control the vehicle's elapsed time. Typically racers will close the throttle STOPA fraction of a second into the pass and reopen the throttle a few seconds later to slow a car for a particular index. To use the STOPB/SLC output only as a Down Track E.T. Control, turn the Start Line Control to OFF (see page 6).
3. Both Starting Line & Down Track Control: This last application allows a racer to use the linkage stop for controlling staging RPM and again during the pass to control the E.T.

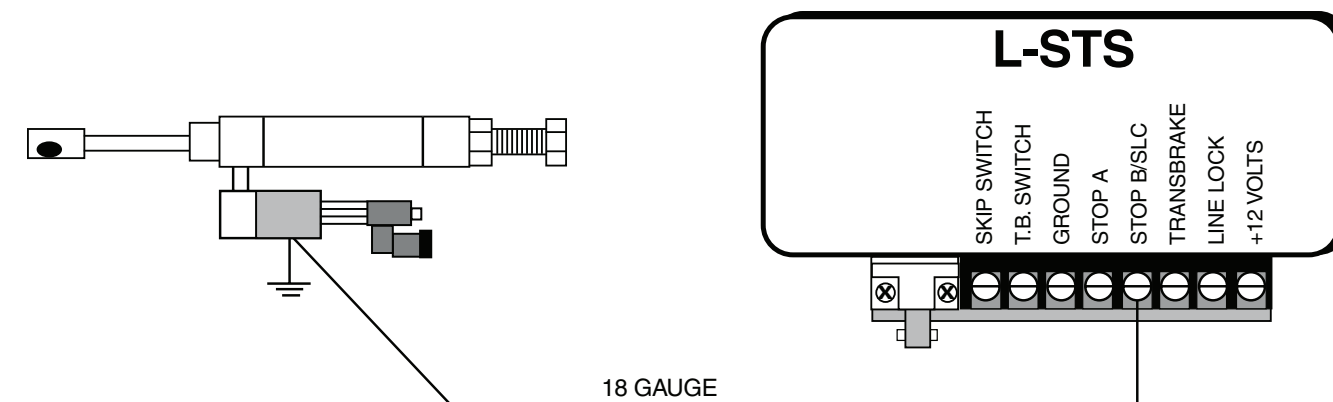

WIRING FOR REMOTE DISPLAY

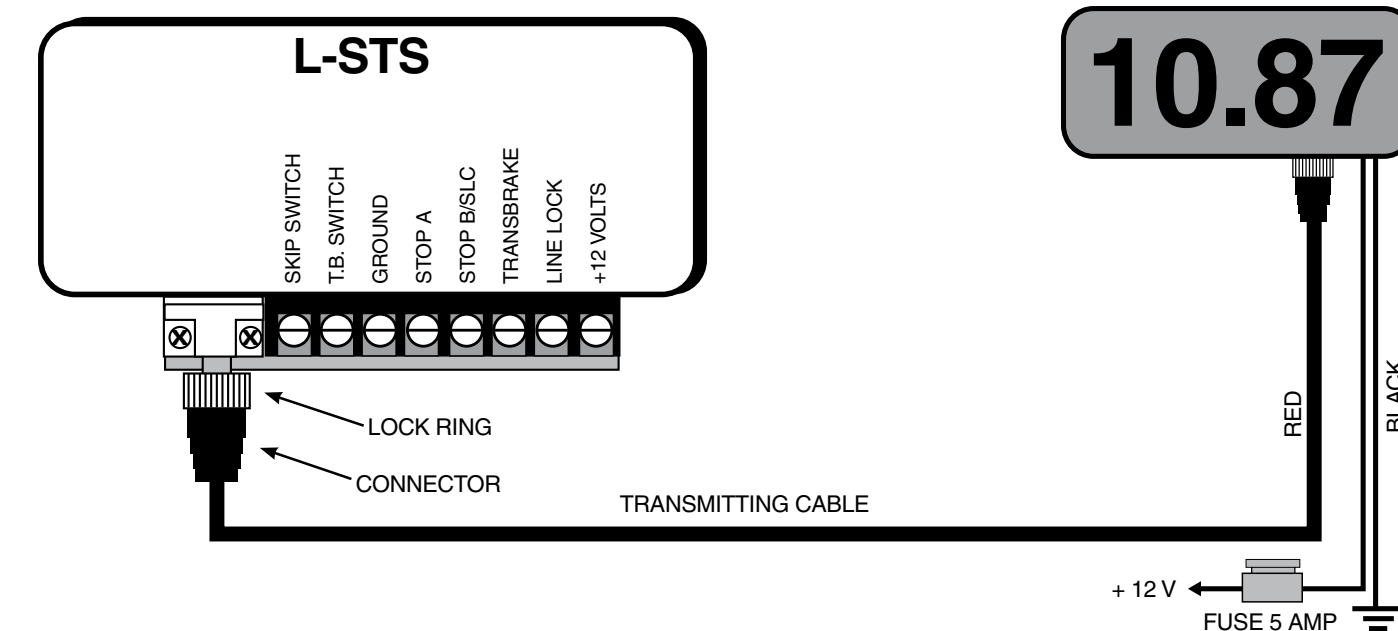

Wire the Remote Display unit as shown. Use at least 18 gauge wire connecting the black wire to a solid chassis ground & the red to + 12 volts. Use a 5 amp fuse in the red wire to protect the Remote Display from damage. Connect the display to your **L-STS** using the transmitting cable included with the display unit. Slip the connectors into the jacks & turn the lock ring clockwise to lock in place.

The display unit needs no set up, just power both units up & the Remote Display will show whatever is dialed in to "YOUR E.T." setting of the **L-STS**. When you make a change to "YOUR E.T." setting in the **L-STS** and the box returns to the run mode, the Remote Display will change accordingly.

WIRING FOR TIMED SHIFTING

The STOPA or B output can be wired to an automated shifter for timing your shift. The following are 3 different types of automated shifters commonly used in drag racing.

1. **CO2 or "Air" Shifter:** Air shifters require +12 volts to be applied to fire the shifter and make the gear change.
Set STOP TYPE to "2-STAGE" and the type to "LINKAGE / DISC"
2. **"Hold" Type Electric Shifter:** Hold type shifters such as Dedenbear models SS-2,3,4,5&6 require a constant +12v to hold the plunger back. At the shift point +12v is removed and the spring pushes the shifter forward.
Set STOP TYPE to "2-STAGE" and the type to "BASEPLATE"
3. **"Push" Type Electric Shifter:** Push style shifters use a large high amperage solenoid that requires the use of a relay or a starter style solenoid to handle the load. These style solenoids use voltage to push the shift lever and make the gear change. You MUST use a relay or starter solenoid to avoid damage to the L-STs.
Set STOP TYPE to "2-STAGE" and the type to "LINKAGE / DISC"

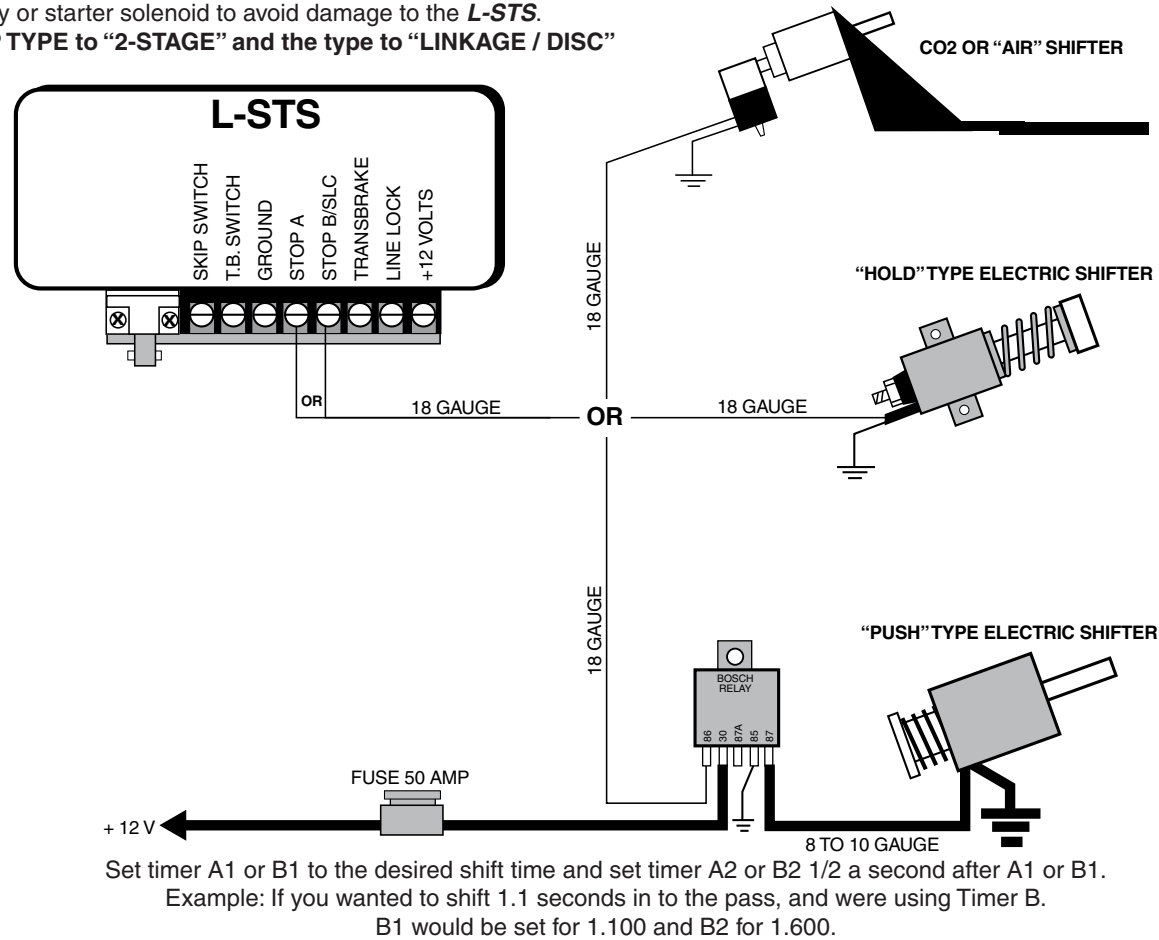

USING A STEPPER STOP

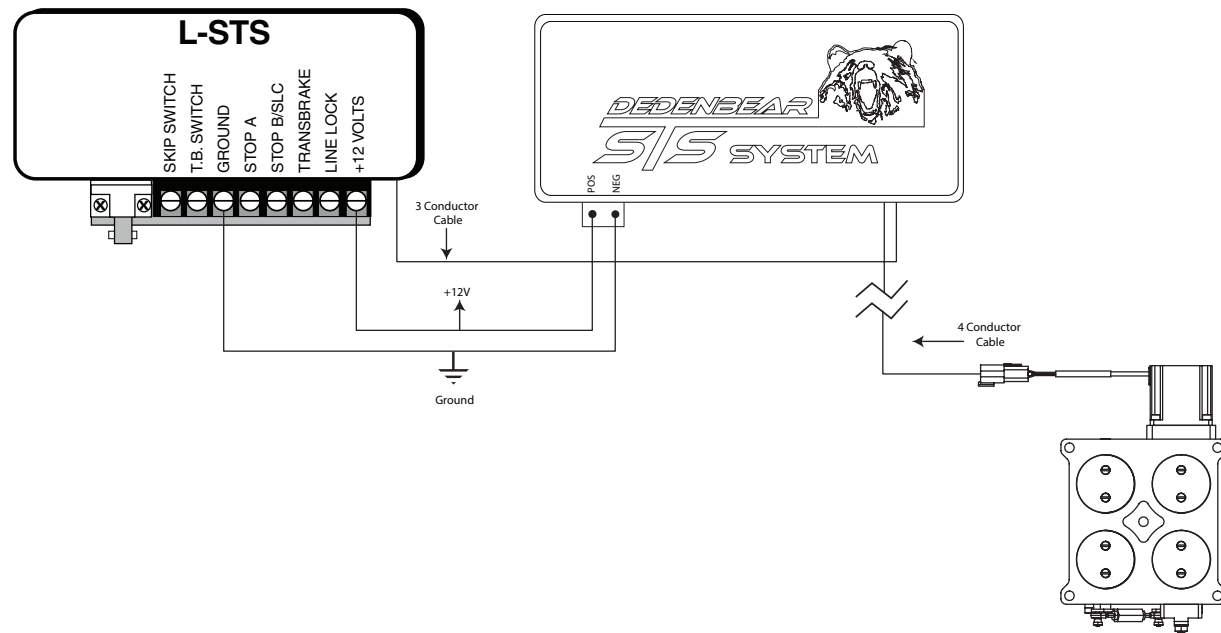

STEPPER SET UP SCREEN

This screen is only displayed when a Stepper Stop is connected and configured.

A1: TIME = 0100
POS: 80 RATE: 1

The stepper setup screen displays the three parameters needed for setting up each stepper stop movement. 3 parameters are required: the time that you want the movement to begin, the position that you want it to move to, and the rate that you want it to move at. The setting that you are adjusting will be capitalized & have an equal sign – the other two will be lower case and have a colon. To move among settings, press the cursor key (right arrow.) When you press the cursor key, the first change you will note is the cursor under the first digit of the time. This allows you to increment each digit by itself making large changes quickly. After you move to the right-most digit of the time, one more press will take you to the position. Here you can adjust position from 0 to 99. Press the cursor button until Rate becomes capitalized then you can adjust the rate from 1 – slowest to 9 – fastest. Press it another time & it will return to adjusting time. You will notice that when the underscore is shown under a digit, that digit can quickly be adjusted up and down.

A2: TIME = 1100
POS: 60 RATE 1

The next feature on this page is the Follow mode. Follow mode allows one to have a movement of the stepper stop immediately follow the previous move. This would be useful when you want to move the stop slowly at first, then quickly. To configure the follow mode, set up your slow movement as desired. For example, say the stop is closed to position 80 by A1 and we want to begin opening it slowly. Set A2 as shown on the left – time to 1.1 seconds - or whatever time you want to begin opening; position 60, or however far you want the stop to move at the slow rate, and rate to your slow rate desired – in this case. Rate: 1

A3 FOLLOW STEP 2
POS = 0 RATE 7

Set movement A3 as follows: Press & hold the RSET key until you see the FOLLOW mode displayed. Now, as soon as A2 has completed making the slow opening to position 60, A3 will begin. A3 will then command the stop to move to position 0 at rate 7, if you've set it up the same as is shown here. If you press & hold the RSET button again, the system will remove the follow mode from A3 & the time displayed will be the time that A3 would have begun in follow mode. It is best to use follow mode & not try to set the times manually if you want them to follow. The reason is that if you change any of the settings of the previous movement, you may introduce an overlap of the movements & cause an error. Using the follow mode also allows you to change the time of this two step (slow, then quick) movement by only changing the time for A2. A3 will shift accordingly when A2 is adjusted.

A4ERRTIME = 2.550
POS: 40 RATE 3

If you set an invalid time, position, or rate, an ERR will be displayed immediately before the word TIME. This notifies you that you are commanding this movement to begin prior to the end of the previous movement or, if this is the last movement, it is not set to 0. Correct these conditions.

NUMBER OF STAGES SCREEN

SET NUMBER OF A
STAGES: 7

This screen is used for configuring the number of stages for both the Stepper and the conventional stops. The Stepper Stop can be configured for anywhere from 1 to 8 stages or disabled – the conventional stop can only be configured for 2 or 4 stages or be disabled.

For the Stepper Stop, the following applies:

Disabled: The stepper stop will not move down track, however the Stepper Stop will still make its starting line control movement / movements.

Any number of stages 0 – 8: The Stepper Throttle Stop will make the programmed movements as configured on the Stepper Setup Screen.

For a conventional stop, the following applies:

Disabled: In the disabled position, the throttle stop output will not cycle. This setting is used when a wide open pass is to be made, or when the Starting Line Control feature is to be used without the throttle stop functioning down track.

2-Stage: A Two Stage timer allows you to cycle the throttle stop one time down track. It will close at A1 or B1 and re-open at A2 or B2. This can also be used to trigger a shift timer or other timed output.

4-Stage: A Four stage timer allows you to cycle the throttle stop twice down track. It will close at A1 and A3 or B1 and B3 and re-open at A2 and A4 or B2 and B4. this can be used for a three speed transmission with timed shifts or other features requiring two full actuation / de-actuation cycles.

STEPPER SLC SCREEN

SLC T BRAKE
POSITION = 40

SLC TIMED = 0100
POS: 60 POS2: 0

SLC T BRAKE
POSITION = 40

The Stepper Throttle Stop has three Starting Line Control modes: TBRAKE SET, TIMED, & PRESTAGE. These modes allow moving the Stepper Stop during staging prior to the start of the race. All movements in Starting Line Control are done at rate 9 – maximum speed. These three modes function as follows:

SLC TBRAKE is used when you want to set the Stepper Stop to a position when the TransBrake is set. This mode simply closes the throttle stop when the TransBrake is set and leaves it at the desired position until A1. This allows you to launch with the stop partially closed to limit power and control tire spin. Use A1 to fully open the STOPAfter launch to regain full power or to close the stop further to increase ET. Set to 0 to disable Starting Line Control for the Stepper Stop.

SLC TIMED works similar to a conventional timed starting line control. When either the Skip Switch is pressed or the TransBrake is set, the stop will close to position

1 (Pos1.) At the set time before TransBrake release the stop will move to Position
2. In the case to the left, the stop will close to position 60 when the Skip Switch is pressed or the TransBrake is set and remain there until 0.100 seconds before the TransBrake is released. This is useful in place of a two step rev limiter. The stop can be programmed to limit your RPM until just prior to the start of the race. Remember however, that the stop takes approximately 0.100 seconds to travel from fully closed to fully open. In the above case, the stop would not be fully opened until approximately 0.040 seconds before TransBrake release. The Delay box will allow you to set this time to 0 and have the STOPBegin moving at TransBrake release. It will automatically handle any conflicts with movement A1. A1 will occur at the time it is programmed and simply change the parameters that the Stepper Throttle Stop is moving to. It is recommended to have a minimum time of about 0.100 seconds here to ensure that the stop is fully opened by TransBrake release. The computation to ensure it is fully opened is as follows:

Time to fully open = POS2 × 0.001

SLC PRESTAGE functions similar to a conventional prestage stop. The throttle stop will close to Position 1 when the Skip Switch is pressed. When the TransBrake is set, it will then move to position 2. This has several uses. It can be configured to allow a driver to stage with his foot on the floor at low RPM (2500) then open to limit RPM to a mid range RPM (4500) once staged. It remains in position 2 until the A1 movement.

STATIC STALL SCREEN

STATIC STALL: 0
UPARROW TO STALL

STATIC STALL: 17
SET 0 TO RESET

Static Stall is used to determine the stall RPM based on the throttle stop position. This mode is designed to require a couple of steps to ensure that you don't set the delay box into this mode on the starting line. This mode is used for setting the stop up in the pits. Ensure that there is no chance of the vehicle moving, tires rotating, or any other vehicle movement that could cause injury. To enter Static Stall, Press the up arrow to increase the Static Stall value above 0. Set your TransBrake and ensure that the vehicle can not / will not move.

Now, press RSET to close the Stop to the set position. The display will now appear as to the left. Start with an intermediate value – somewhere in the 60's or 70's. Remember that as you increase the value, the stop will close. If the engine begins to stumble, decreasing the value will open the throttle STOPBlades. Slowly depress the accelerator pedal and ensure that the tires are not rotating and that the vehicle is not moving. When you reach full throttle, record the RPM that corresponds to the Stepper Stop throttle position. Do this for several values in the range of RPM that you'd like to control your engine. These values are a baseline based on the weather, engine temperature, etc... that will vary. Also, expect that your actual RPM on track will be roughly 200 RPM greater due to the TransBrake not being set.

To exit this mode, release the accelerator pedal & allow the engine to return to idle. Use the down arrow to set the Stop position to 0, then press RSET to return to normal operation. Once you know how your engine responds to Stepper throttle Stop position, you'll be better equipped to tune your vehicle for optimum performance.