

COMMAND CENTER 3 INSTALLATION & OPERATION MANUAL

INDEX

Installation Instructions.....	pg 1	RPM Switch & Throttle Stop C.....	pg 6
Pro-Full Feature.....	pg 2	Digital Tachometer.....	pg 6
Button Use & Programming.....	pg 2	General Info / Definitions.....	pg 7
Types of Delay Boxes.....	pg 3	Transbrake Wiring.....	pg 8
Setting Transbrake Delay.....	pg 3-4	Throttle Stop & Nitrous Wiring.....	pg 9
Setting Throttle Stop Types & Timers...	pg 4-5	Linkage Style Stop Wiring.....	pg 10
Starting Line Control.....	pg 5	RPM Switch & Remote Display Wiring.	pg 11
Super Start System.....	pg 5	Setting Parameters.....	pg 12

INSTALLATION

Using #8 screws through the rubber grommets in the base, mount the Command Center away from heat, vibration and the ignition system.
 Make sure the driver can reach the buttons when strapped in and angle the unit if needed so the display can be read straight on. If the box is mounted so the display is viewed more than 10 degrees off center, it will be hard to read.
 Wire the Command Center as shown on pages 8-11. Make sure the power lead comes straight from the master switch and the ground goes to a solid chassis ground, not sheet metal panels.

BUTTON QUICK REFERENCE

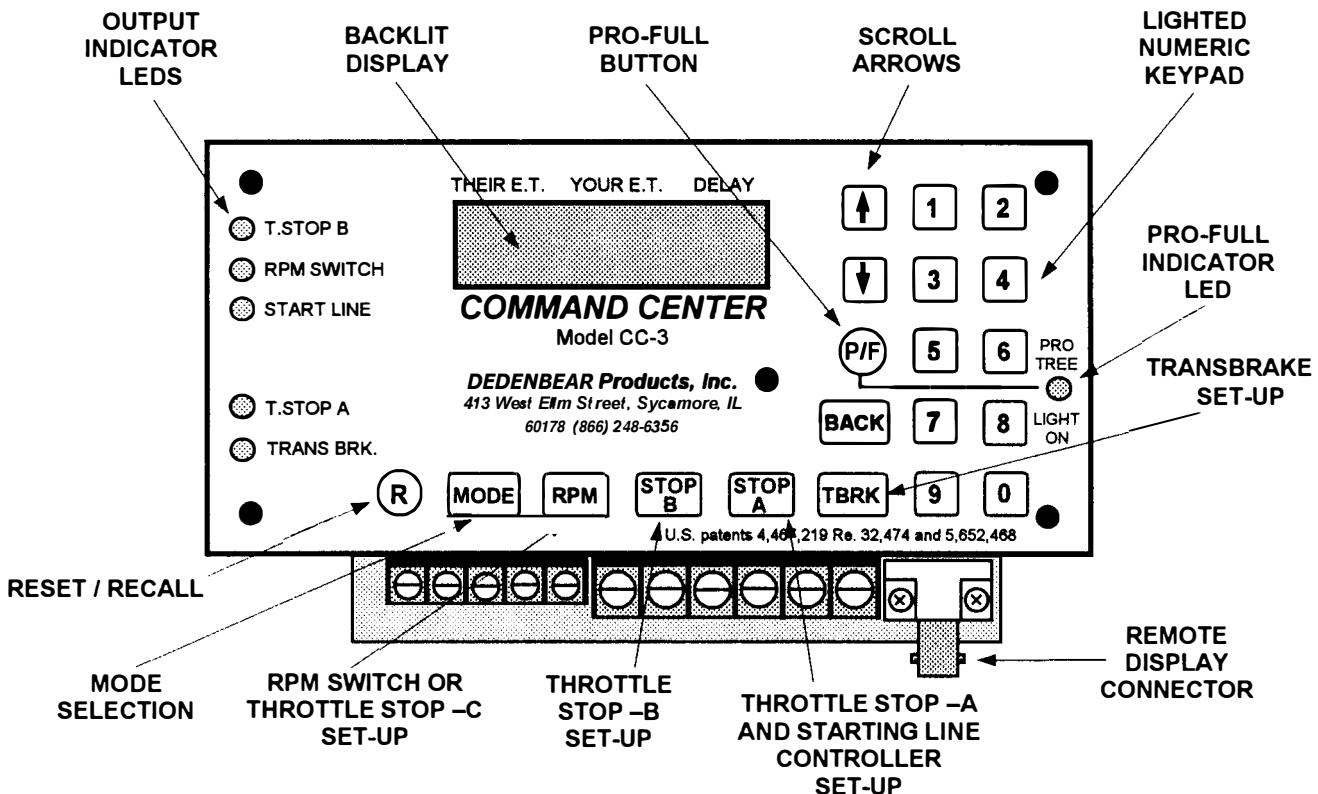

BUTTON USE AND SETTINGS

The CC-3 has many selections that can be programmed for each setting. Each time you push the button for the particular setting you are adjusting, it will step you to the next prompt screen. The CC-3 will only ask for the settings needed for the particular mode you are in, for example when adjusting settings for throttle stop A, the CC-3 will not ask for the settings for your transbrake delay. At each prompt screen you can change a setting by using the scroll buttons or the number keys. If no adjustment is needed for a setting, press the button again to step to the next screen. After your adjustments are made, the CC-3 automatically returns to the run mode after 8 seconds.

PRO-FULL BUTTON

The CC-3's **PRO-FULL** feature allows you to switch between two complete setting groups for the delay box, throttle stop and RPM features. This enables you to program the box for your "Super" class settings in **PRO**, and then program your bracket race settings in **FULL**. Now when you switch between classes you no longer need to re-program the CC-3, just push and hold the PRO-FULL button to switch between groups of settings. The red LED indicator light on the right side of the box will indicate which setting group you are in. When you are in the **PRO** group, the **PRO-FULL** LED will turn on and stay on. When you are in the **FULL** group, the LED will be off except for momentary flashing while making adjustments which is normal.

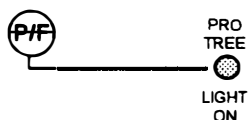

REMEMBER: It is extremely important when you change a setting that you are in the setting group (PRO or FULL) in which you want the change to occur since each group has it's own complete set of settings.

PROGRAMMING BUTTONS



TBRK Button: This button accesses your Transbrake settings. Each time you press the TBRK button, different set-up screens come up and allow you to make changes to your Delay, Delay 2, Your ET, Their ET, Bottom Delay, Cross Comp, Skip Up/Down, TB Pause, & TB Lockout settings.



STOP A Button: This button accesses your Throttle Stop Controller A and the Starting Line Controller settings. Each time you press the STOP A button, different set-up screens come up and allow you to make changes to your 4 Timer settings (timer A1 to A4) and your Starting Line Controller settings.



STOP B Button: This button accesses your Throttle Stop Controller B settings. Each time you press the STOP B button, different prompt screens come up and allow you to make changes to your 4 Timer settings (timer B1 to B4).



RPM Button: This button accesses your RPM Activated Switch OR Throttle Stop Controller C settings. Each time you press the RPM button, different set-up screens come up and allow you to make changes to your Shift Point (Time or RPM), Disable Time, Shifter Type, and Number Of Cylinders OR switch to STOP C and change your 4 Timer settings (timer C1 to C4).



Arrow (scroll) Buttons: These buttons are used for making small changes to your settings. You can add to a setting by pressing the up arrow, or subtract with the down. If you push and hold an arrow key, the setting will continue to change faster and faster.



Number Buttons: These buttons are used for making large changes to your settings. Simply type in the number you want. For example, if you wanted to change an E.T. to 12.73, you would press 1273.



BACK Button: This button is used if when stepping through the set-up screens you accidentally pass the screen you wanted. Press the Back button to move back one set-up screen.



Reset/Recall Button: This button is used for setting the box for the type of equipment it will be running like Throttle Stop Type, Shifter Type, Number of Cylinders, etc. Press and hold the R button to make the change. This button also can be used to cancel the throttle stop timers during the pass and recalls information about the run after the pass has been made.



MODE Button: This button selects which of the 4 delay box modes you wish to run. They are Delay, Crossover, Interface and Cross Talk.

DELAY BOX TYPES

The CC-3 has four different types of delay boxes built in. They are:

1. **DELAY:** A simple 4 digit delay box used for pro tree classes and leaving off your top amber for full tree classes. The box simply delays for the time set and releases the transbrake.
2. **CROSSOVER:** Used in full tree bracket racing for launching off your opponents top bulb when you are the faster car. The box calculates the handicap and adds it to your delay time.
3. **INTERFACE:** This is used the same as crossover except it allows you to take two hits at the tree. You leave off the opponent's top bulb, press the transbrake button again, then release off your own top bulb. The box will release the transbrake on the *quicker* of the two releases. This means if your release on the opponent's top bulb gives you a .520 light and the release on your top bulb gives you a .505 light, the box will launch the car on the .505 light. Remember, the interface always chooses the *quicker* light and will choose a .490 over a .500.
4. **CROSS TALK:** Used for the cross talk bracket tree, this mode functions the same as the Interface mode except it allows you to take two hits at your tree, one off your top amber, and one off your second amber. Like the interface the box will choose the *quicker* of the two reaction times.

To change between the delay box types, press the MODE button. Continue until the mode you want appears.

SETTING TRANSBRAKE DELAY

To set your transbrake delay you must first choose which delay box type you wish to run by pressing the MODE button. The CC-3 will only ask you for the settings required for that particular mode. Example: When you are in RUN (DELAY) it will not ask you for THEIR ET setting since you are not crossing over. All of the shared settings between these modes will transfer when you change to a different mode. Example: Your delay setting will transfer over to all four different delay box modes along with your SKIP, TB PAUSE, and TB LOCK OUT settings.

THEIR ET YOUR ET DELAY

10.00 9.00 1.000
RUN (INTERFACE)

RUN SCREEN: This is the screen the CC-3 will display when it is "ready to run". It will always display YOUR ET and your DELAY. When in Crossover, Interface and Cross Talk modes it will also display THEIR ET.

NOTE: If you are not using the remote display dial-in board (part# RD-1) the YOUR ET setting is not important when in the DELAY mode. This setting will not effect your delay time whatsoever.

TBRK

Press the TBRK button to enter the transbrake adjust settings menu. Each time you press this button it will advance to the next set-up screen. Once you have advanced through all of the screens, the box returns back to run mode. If you happen to go too fast and pass the set up screen you want, you can use the BACK button to back up. When you are through making adjustments to the settings, the box will automatically return to the run mode in 8 seconds.

SETUP MODE
DELAY 1.000

DELAY: When you first press the TBRK button, the delay setting will appear. Use the scroll arrows or the number buttons to change this setting. For leaving off the top bulb on a full tree, this setting is typically around 1.000 second.

SETUP MODE
DELAY 2 .500

DELAY 2: This screen will appear next only in Cross Talk mode (not needed in Delay, Crossover or Interface). Delay 2 is the amount of delay used for taking a 2nd hit at the 2nd amber bulb on a cross talk bracket tree. Typical 2nd amber delay setting is around .500 second. Use the scroll arrows or number buttons to change this setting.

SETUP MODE
THEIR ET 10.00

THEIR ET: This is the next screen that will appear in Interface, Crossover and Cross Talk modes (not needed in Delay mode). Use the scroll arrows or number buttons to change this setting to your opponent's dial-in.

SETUP MODE
YOUR ET 09.00

YOUR ET: This is where you enter you own vehicle's dial-in. Use the scroll arrows or number buttons to make changes. If you run a Remote Display dial-in board, this is the setting that will be displayed upon return to run mode.

SETTING TRANSBRAKE DELAY (continued)

SETUP MODE
BOT DELAY .100

BOT DELAY: Bottom bulb delay time is the amount of delay you need for a bottom bulb release on a full tree. This is the delay for the "Last Chance" feature while in Interface and Cross Talk modes. Adjust with scroll or number buttons.

SETUP MODE
CROSS COMP .015

CROSS COMP: Crossover compensation time is used to compensate for late lights when crossing over. When you cross over and leave off your opponent's tree you get an indirect view of his top bulb instead of a direct view like on your side. This results in a reaction time that is about .010 to .020 seconds slower. Crossover compensation automatically subtracts this time from your delay setting whenever you crossover. Use the scroll arrows or number buttons to change this setting.

SETUP MODE
SKIP DOWN -.015

SKIP DOWN or SKIP UP: This is the amount of time you want to add (Skip UP) or subtract (Skip Down) from your delay time *after* you have released the transbrake button. If you feel you "missed" the tree, every time you push the skip button the box will add or subtract this amount from your delay time. Use the scroll arrows to change this setting.

SETUP MODE
TB PAUSE .100

TB PAUSE: This is the amount of time the box pauses from when the transbrake button is depressed until the transbrake sets. This prevents transbrake application if the button is accidentally bumped or brushed while driving down the return road or in the staging lanes.

SETUP MODE
TB LOCKOUT 03

TB LOCK OUT: This is the amount of time the box will lock out the transbrake so the driver can not re-apply the transbrake during the pass. Use the scroll arrows or number buttons to change the lock out in increments of whole seconds.

THROTTLE STOP

The CC-3 has 2 separate 4 stage throttle stop controllers (a 3rd controller is available if the RPM output is not used. See the RPM switch section for details) plus an independent Starting Line Control (SLC) output. The throttle stop outputs can be used to time just about any 12 volt device. Besides throttle stops, common uses are timed shifts, nitrous systems, ignition retards, lean outs, etc. The Stop A and Stop B outputs are rated at 30 amps each, while the RPM and SLC outputs are rated at 10 amps each.

STOP
B

STOP
A

To set your throttle stop timers, press the STOP A or STOP B button to enter each of the respective timer menus. Each time you press the button it will advance to the next set-up screen. The procedure is the same for changing settings as in the TBRK menu. After advancing through all the screens, or after 8 seconds without making a change the box returns to run mode. If you happen to go too fast and pass the set-up screen you wished to change, you may use the BACK button to back up.

A1: 1.000 A3 3.00
A2: 2.000 A4 3.00

The first screen that will be displayed is a summary screen that shows you all 4 of your throttle stop timer settings for quick reference. Note that timers 1,2,3 & 4 are preceded with a letter. A1 represents Stop A timer 1, B3 would be Stop B timer 3. Like all the other prompt screens, this screen will disappear and return to run mode

after 8 seconds.

In this example notice how timer A2 is set higher than A1, and A3 & A4 are set the same. All the timers must be set sequentially larger meaning timer 2 must be equal to or larger than timer 1, timer 3 must be equal to or larger than timer 2 and timer 4 must be set equal to or larger than timer 3. If you accidentally set a timer lower than the previous timer the "STOP A SET WRONG" error message will appear. Reset the timers in proper sequence to eliminate the error. Also know that when timer 1 & 2 or timer 3 & 4 are set the same as one another they will cancel each other out and the output will not change.

THROTTLE STOP TIMERS (continued)

SETUP THROTL STP A1: 1.000 SECONDS

The four set-up screens following the summary screen are where you change your throttle stop timers. Use the scroll arrows or the number buttons to make changes. All four timers start timing at release of the transbrake solenoid so if you had 1.000 in timer 1, 2.000 in timer 2, 3.00 in timer 3 and 3.00 in timer 4 the car would launch

at wide open for 1 second, the throttle stop would close for 1 second (duration = timer 2 minus timer 1) and then go wide open for the remainder of the pass (timer 3 & 4 cancel each other out). **Please note that timers 1 & 2 are adjustable to the thousandth of a second and timers 3 & 4 are adjustable to the hundredth.**

THRTTL STP TYP A BASE PLATE STYLE

The 5th set-up screen in the throttle stop menu is where you can change your throttle stop type. Press and hold the "R" button while this screen is up to change from "BASE PLATE STYLE" to "LINKAGE STYLE" or vice versa. This changes the output polarity to correctly run whatever device you've wired to the output.

Typical devices and the correct setting or "type":

- Under the carb "Butterfly" throttle stops use : BASE PLATE STYLE (power turns off at timer 1)
- Under the carb "Disc" throttle stops use: LINKAGE STYLE (power turns on at timer 1)
- In-line "Linkage" throttle stops use: LINKAGE STYLE (power turns on at timer 1)
- Nitrous Oxide systems use: LINKAGE STYLE (power turns on at timer 1)
- Dedenbear Solenoid Shifter "Hold type" use: BASE PLATE STYLE (power turns off at timer 1)
- CO2 or "Air" shifters use: LINKAGE STYLE (power turns on at timer 1)

STARTING LINE CONTROL AND SUPER START SYSTEM

STOP A

Starting Line Control (SLC) is accessed through the STOP A menu as the 6th set-up screen. There are 4 different SLC options (see below for individual descriptions) all of them control the output at the Starting Line Control terminal on the CC-3. This output is wired to a linkage style throttle stop to control your staging RPM in various ways. Press and hold the "R" button to flip through these options.

The Super Start System is a feature that allows you to activate your Starting Line Control BEFORE you stage the vehicle allowing you to stage with your foot on the floor. The Super Start works differently in each of the SLC modes, see below for specific functions.

SLC START LINE TBRAKE RELEASE

SLC Transbrake Release functions as follows: At application of the transbrake (when you press the transbrake button) the linkage stop will close your throttle. At transbrake solenoid release (launch) the linkage stop will pull the throttle wide open. If you wish, the Super Start can be used in this mode also. Momentarily press the

Skip Button prior to staging the car and the linkage stop will close right then so you can stage the car with your foot on the floor. The linkage stop will still pull wide open at transbrake release.

SLC START LINE TIMED : 1.000

SLC Timed functions as follows: At application of the transbrake (when you press the transbrake button) the linkage stop will close your throttle. At the predetermined time (whatever is set in this set-up screen) BEFORE transbrake solenoid release (launch) the linkage stop will pull the throttle wide open. Using this feature will allow

you to have the car come up against the converter or 2-step for exactly the same amount of time every pass whether you are crossing over or launching off your tree. If you wish the Super Start can be used in this mode also. Momentarily press the Skip Button prior to staging the car and the linkage stop will close right then so you can stage the car with your foot on the floor. The linkage stop will still pull wide open at the predetermined time before transbrake release.

SLC START LINE PRESTAGE

SLC Prestage functions as follows: In this mode you must activate the Super Start System prior to staging by momentarily pressing the Skip Button to have the linkage stop close your throttle. At activation of the transbrake solenoid (when you press the transbrake button) the throttle will immediately pull to wide open so the motor will

come up against the converter or 2-step for the entire staging duration. This mode is primarily used in pro-tree classes with short staging durations but can be used with a full tree if desired.

SLC START LINE TURNED OFF

SLC Turned Off: If you wish to run without the aid of your Starting Line Control you can simply turn the output off. In this mode the SLC will do nothing.

RPM ACTIVATED SWITCH / THROTTLE STOP C

The CC-3 has a built in RPM activated switch. It is compatible with all aftermarket electronic ignition systems including MSD, Mallory, Holley, Crane and Accel and can be used on 4,6 & 8 cylinder engines. It is not compatible with standard (points) or HEI type ignitions. It may also be used with a magneto ignition if a tach converter is used. The RPM switch can be used to shift by RPM, or by time, it can also shift 3 speed transmissions at two different RPM points. If the RPM switch is not being used it may also be turned into a third 4 stage throttle stop controller (Stop C) for timing another device down track.

RPM

Press the RPM button to access the RPM switch set-up screens. The first thing to do is decide if you want to use the RPM switch output for a 2 speed transmission, a 3 speed transmission, or as a third 4 stage throttle stop controller.

SET RPM OR TIMER 2 SPEED RPM

Press the RPM button until one of these set-up screens appear (5 to 7 times depending on which mode you are currently in) then press the "R" button to change from mode to mode.

- **2 SPEED RPM:** For use with 2 speed transmissions (or 3,4 & 5 speeds that wish to make all shifts at the same RPM). Every time the shift point is reached the CC-3 will output. Once the motor has dropped 200 RPM below the shift point, the switch will reset and shift again once the shift point is reached.

SET RPM OR TIMER 3 SPEED RPM

- **3 SPEED RPM:** For use with 3 speed transmissions that wish to shift at 2 different RPM points. In this mode the CC-3 will shift the 1-2 at one RPM and once the motor has dropped 200 RPM shift the 2-3 at a different RPM. Every time the transbrake is applied, the sequence is reset and the CC-3 will go back to the 1-2 shift.

SET RPM OR TIMER TIMER

- **TIMER:** In this mode the RPM output will become a third 4 stage throttle stop controller "STOP C". Stop C will function identically to the Stop A & B outputs. See page 4 for set-up instructions.

SET 1-2 SHFT RPM 7200 RPM

When in 2 Speed or 3 Speed RPM mode the first set-up screen will be your shift RPM. Use the scroll arrows or the number buttons to adjust the 1-2 shift point.

SET 2-3 SHFT RPM 7500 RPM

When in 3 Speed RPM mode (this set-up screen will not appear in the 2 Speed mode) the second set-up screen will be your 2-3 shift RPM. Use the scroll arrows or the number buttons to adjust the 2-3 shift point.

SETUP DISABL TIM .500 SECONDS

Following the shift point set-up screens you will find the Disable Time. This is the amount of time from the release of the transbrake solenoid that the RPM sensing circuit is disabled. If the car experiences tire spin or converter flash right off the starting line, this setting will prevent accidental up-shifting for the amount of time programmed in. After the disable time expires, the RPM sensing circuit will resume looking at the engine RPM and when the RPM preset is reached, it will shift the shifter. Use the scroll arrows or the number buttons to adjust your disable time.

SETUP SHFTR TYP AIR

Press and hold the "R" button in this set-up screen to change your shifter type. Set the shifter type to "AIR" (power off until shift point then turned on) when using CO2 or air shifters, or electric "push" style shifters. Set the shifter type to "ELECTRIC" (power on until shift point then turned off) when using an electric "hold" style shifter.

SETUP # OF CYLINDERS: 8

Press and hold the "R" button in this set-up screen to change the number of cylinders from 8 cylinders to 6 cylinders, again for 4 cylinders, and again to return to 8 cylinders.

TACHOMETER 3500 RPM

The CC-3 has a built in tachometer for testing the tach signal coming in to the box. It can show you if the RPM switch is receiving a good signal. Press the RPM button once to bring up the SET 1-2 SHIFT RPM set-up screen then push and hold the "R" button to display the tachometer. As long as you hold the "R" button the tachometer will stay displayed. Release the button to return to the set up menu.

GENERAL INFORMATION AND DEFINITIONS OF FEATURES

Reset/Recall Button: Used to change the settings for the type of equipment on your car. For example, the number of engine cylinders, type of throttle stop and shifter, how you want the starting line controller set up, etc. To use it for these applications, go to the set-up screen for the feature you wish to change, press and hold the "R" button until the box changes its set up. If pressed during a pass the "R" button will cancel the throttle stop timers and return to a ready to run condition. If pressed after the run the "R" button will recall the "How Late" information and how many times you "Skipped".

ARP (Accidental Release Protection): Occasionally you may anticipate the lights and release the button too early. ARP lets you recover from this situation. In Delay and Crossover modes, you simply press the transbrake button again before the car launches and the CC-3 will instantly reset itself. In Interface and Cross Talk modes this does not work because the CC-3 is expecting a second hit. To avoid a red light you can use the Last Chance feature.

Last Chance: This feature works only in Interface and Cross Talk modes. If you think either or both of your releases were too quick, press the transbrake button down a third time to cancel the first two hits, then release the button off your bottom bulb to launch the car. If your car red lights off the bottom bulb, add some time to the Bottom Bulb delay and the Last Chance feature will use the delay from that setting.

How Late: In the Interface and Cross Talk modes where you can take two hits at the tree, the How Late feature tells you which of the hits was faster and by how much. In Interface mode the How Late timer will display "THEIR TREE BY: .XXX" or "YOUR TREE BY: .XXX" or "LAST CHANCE ACTIVATED". As an example, if you were in Cross Talk mode, the display might read "FIRST HIT BY: .023". This means that you were quicker leaving off your top bulb than your second bulb and that you were .023 seconds quicker. The CC-3 released the transbrake off the top bulb hit in this example. If you had cancelled the first two hits by pressing the button a third time, the display would read "LAST CHANCE ACTIVATED". After a run is made the How Late information is recalled by pressing and holding the "R" button. The display will alternate between the How Late information and the number of Skips.

Skip Recall: Skip Recall tells you the number of times you pressed the Skip button during the delay box time out. By checking the set up menu you can determine how much time each Skip was and whether it added or subtracted time to the delay setting. By multiplying the Skip time by the number of Skips, you can calculate the total amount of time that was added or subtracted from your delay time. The number of Skips used can be recalled after the run by pressing and holding the "R" button. The display will alternate between the How Late information and the number of Skips.

Throttle Stop Settings Incorrect: If a throttle stop timer is accidentally set lower than the preceding timer (timer 2 set lower than timer 1 or timer 3 set lower than timer 2, etc.) this message will appear. Change the timers to correct the problem. If the run is made without fixing the problem, the affected timer will not cycle (if the timer is running a throttle stop the car will run wide open).

Dial-ins Incorrect: If the Their E.T. setting is accidentally set lower than the Your E.T. setting this message will be displayed. If you make a pass without fixing the problem, the CC-3 will assume the handicap is zero and will only use the delay setting.

Line Lock Output: The Line Lock Output is exactly the same as the Transbrake Output except that it is diode protected. This means that if wired in (see page 8) the delay box will operate the line lock on the starting line, but the line lock will not back feed to the transbrake solenoid while doing a burnout.

Leaving Set Up Menus, Five Ways To Leave:

- 1) Do nothing and the unit will return to the run mode automatically after 8 seconds.
 - 2) Press the Transbrake button and the unit will instantly return to run mode.
 - 3) Clock through the set up menu by repeatedly pushing the setting button until you get back to run mode.
 - 4) Go backwards through the set up menu by repeatedly pushing the BACK button.
 - 5) Change set up modes (I.e. in the Transbrake set up you can press the STOP A button and jump directly to the set up menu for STOP A, etc.)
-

Memory: The microprocessor in the CC-3 will remember all of your settings, even after turning off the power. There are no internal batteries to die, so the unit will keep your last settings forever.

Battery Chargers: It is important to make sure to have your master disconnect switch off while hooking up your charger between rounds. When the first contact is made between the charger and the battery there may be a voltage spike that could damage electronics. After the charger is hooked up the master switch can be turned back on to run the water pump, fan, etc.

Temperature: If the CC-3 ever gets over 160 degrees, the display will get dark and unreadable. This does not damage the unit, simply cool it off and the display will return to normal.

WIRING THE TRANSBRAKE BUTTON, BYPASS TOGGLE AND SKIP BUTTON

1. Wire the 12v power supply wire **directly** to the master on-off switch at the back of the car. Use at least 10 gauge wire. Do **not** wire the power supply to the starter solenoid, Ford style solenoid, switch panels or existing fuse blocks. Install the appropriate size fuse or circuit breaker (see diagram for fuse size) to protect the CC-3 from short circuits.
2. Install a 14 gauge wire from the ground terminal to a solid chassis ground, do **not** use the same ground that the ignition box uses and do **not** use aluminum or sheet metal panels as these are not reliable grounds.
3. Wire the transbrake solenoid directly to the Transbrake terminal using minimum 14 gauge wire.
4. If you are going to use a rev limiter on the starting line, tie the rev limiter activation wire in with the transbrake wire.
5. Wire one side of the transbrake button to the T.B. Switch terminal using 14 gauge wire.
6. Supply power to the other side of the transbrake button from the +12 volt terminal on the CC-3 using 14 gauge wire.
7. If you wish to use the **optional** skip button, supply power to one side of the button from the CC-3's +12 volt terminal using 18 gauge wire.
8. Run a wire from the other side of the skip button to the Skip Switch terminal on the CC-3 using 18 gauge wire.
9. If you wish to use the **optional** line lock output on the CC-3 to simultaneously hold the line lock and transbrake on the starting line, run a 14 gauge wire from the Line Lock terminal on the CC-3 to the line lock solenoid.

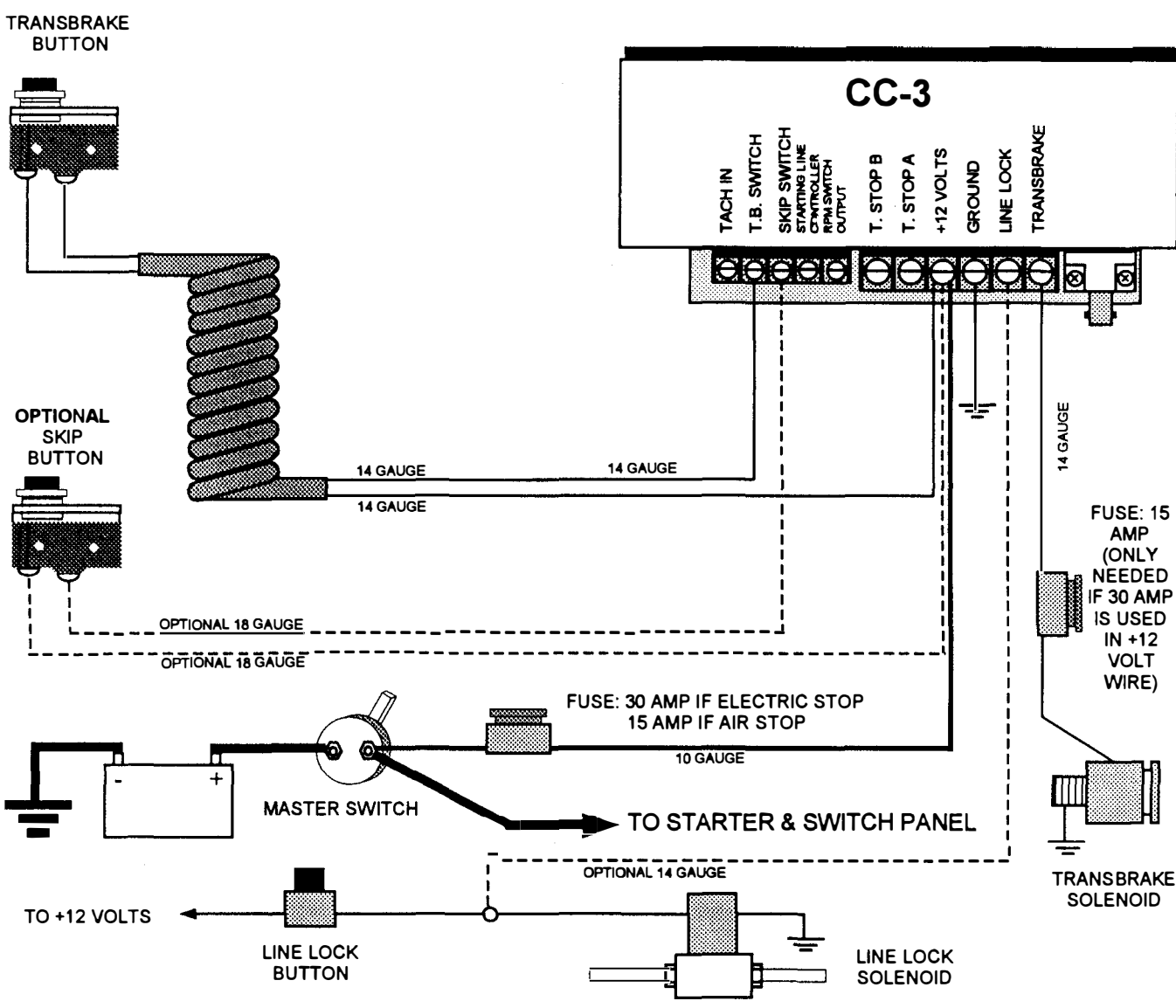

WIRING FOR BASEPLATE STYLE THROTTLE STOPS

For electric "butterfly" throttle stops set stop A to "BASEPLATE TYPE".

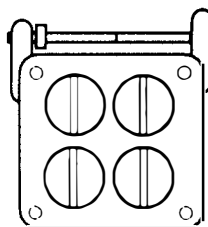

For air "disc" throttle stops set stop A to "LINKAGE TYPE".

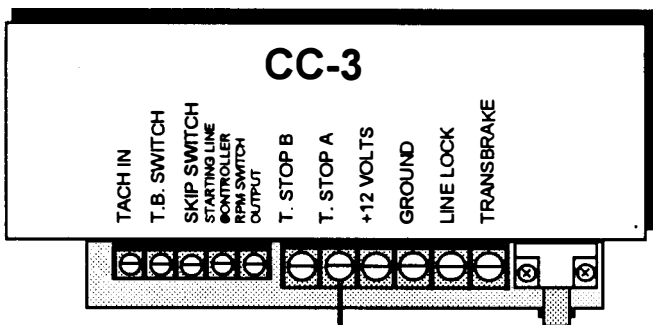
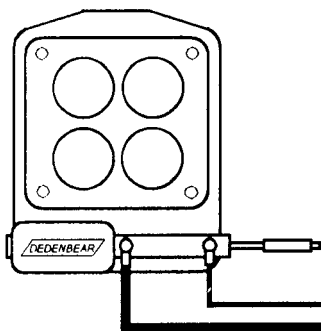

10 GAUGE

OR

18 GAUGE

Use 10 gauge wire for electric throttle stops and 18 gauge for air throttle stops.

WIRING FOR 2 STAGE NITROUS SYSTEM

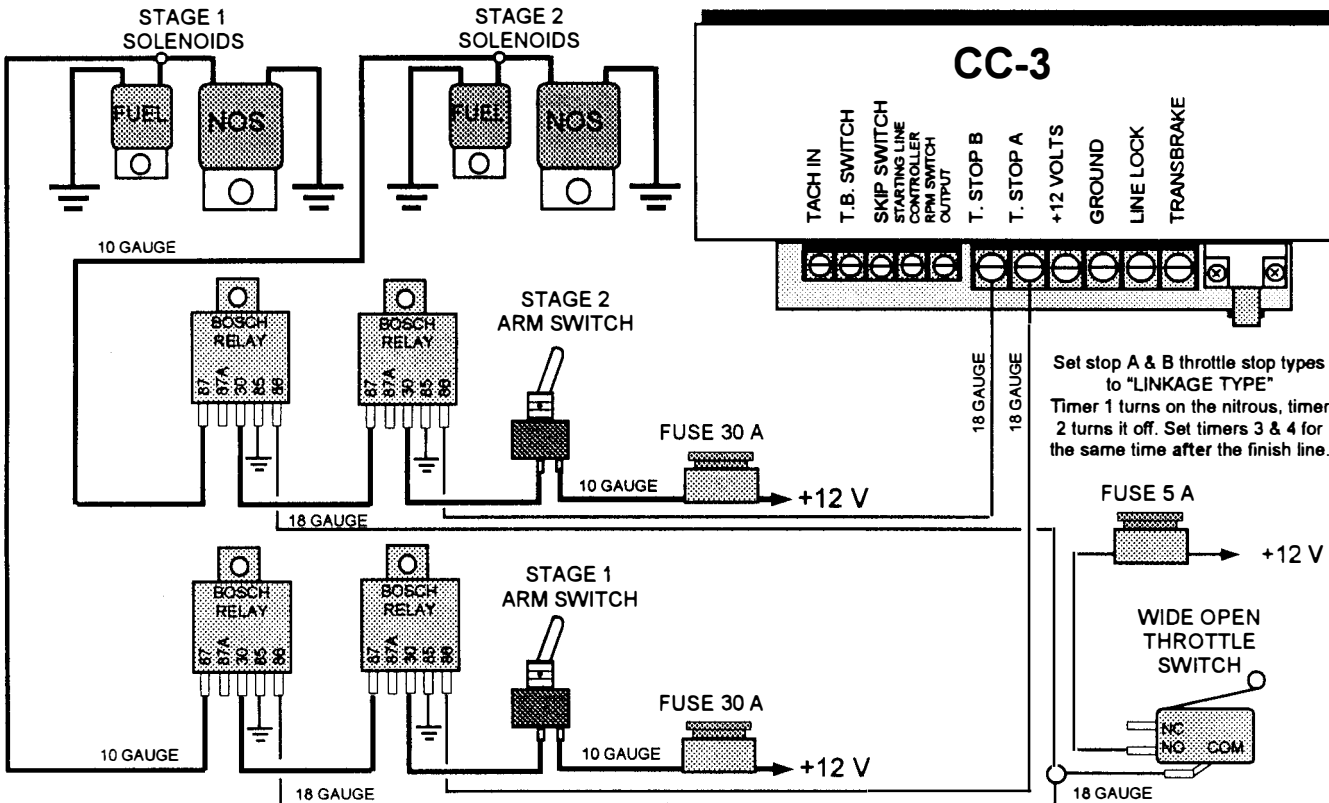

Set stop A & B throttle stop types to "LINKAGE TYPE".
Timer 1 turns on the nitrous, timer 2 turns it off. Set timers 3 & 4 for the same time after the finish line.

WIRING FOR LINKAGE STYLE THROTTLE STOP

There are 3 different ways to wire a linkage style throttle stop. They are as follows:

1. **Starting Line Control:** In this application the linkage stop closes on the starting line when the transbrake is applied (or prior to staging if the pre-stage feature is activated). This is to control the staging RPM of the engine. See page 5 for a complete description of starting line control options.
2. **Down Track E.T. Control:** In this application the linkage stop is used only during the pass to control the vehicle's elapsed time. Typically racers will close the throttle stop a fraction of a second into the pass and reopen the throttle a few seconds later to slow a car for a particular index.
3. **Both Starting Line & Down Track Control:** This last application allows a racer to use the linkage stop for controlling staging RPM and again during the pass to control the E.T.

WIRING FOR STARTING LINE CONTROL

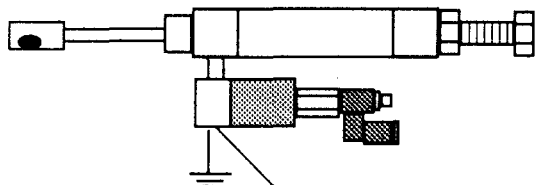

In this application simply wire your linkage type throttle stop directly to the STARTING LINE CONTROL terminal on the CC-3. You can access the SLC options by pressing the STOP A button.

18 GAUGE

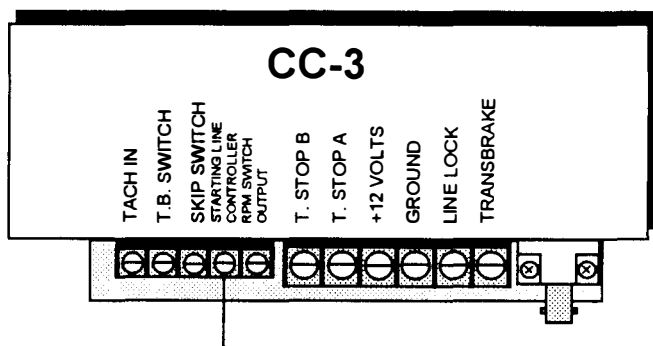

WIRING FOR DOWN TRACK E.T. CONTROL

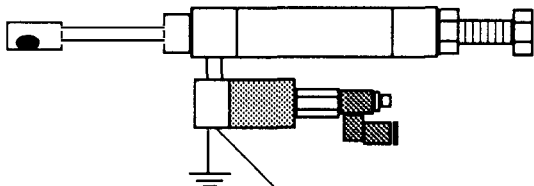

In this application simply wire your linkage type throttle stop directly to either the T.STOP-A, T.STOP-B, or RPM OUTPUT (if T. STOP C is used). You can access the throttle stop timers and SLC options by pressing the STOP A, STOP B or RPM button respectively.

18 GAUGE

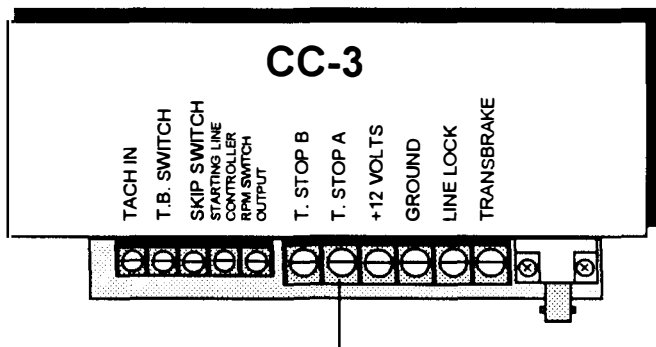

WIRING FOR STARTING LINE CONTROL & DOWN TRACK E.T. CONTROL

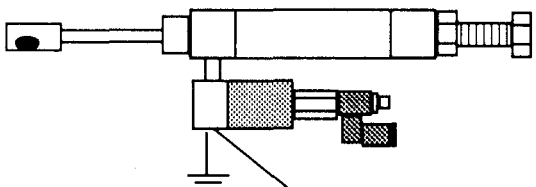

In this application simply wire your linkage type throttle stop directly to either the T.STOP-A, T.STOP-B, or RPM OUTPUT (if T. STOP C is used) then a jumper wire to the STARTING LINE CONTROL terminal. You can access the throttle stop timers and SLC options by pressing the STOP A, STOP B or RPM button respectively.

18 GAUGE

18 GAUGE

JUMPER

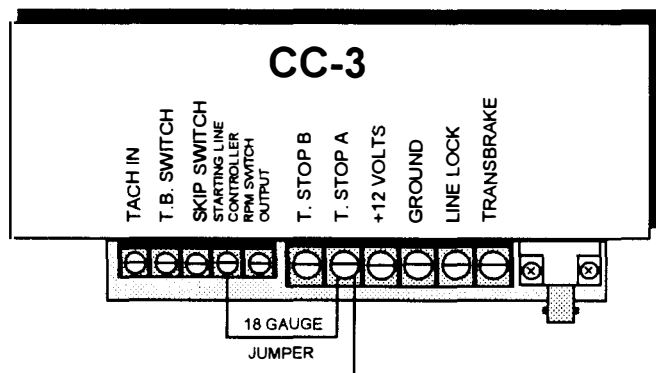

WIRING FOR AIR AND ELECTRIC SHIFTERS

There are 3 different types of automated shifters commonly used in drag racing. They are:

1. **CO2 or "Air" Shifter:** Air shifters require +12 volts to be applied to fire the shifter and make the gear change. **SET SHIFTER TYPE TO "AIR" SHIFTER**
2. **"Hold" Type Electric Shifter:** Hold type shifters such as Dedenbear models SS-2,3,4,5&6 require a constant +12v to hold the plunger back. At the shift point +12v is removed and the spring pushes the shifter forward. **SET SHIFTER TYPE TO "ELECTRIC" SHIFTER**
3. **"Push" Type Electric Shifter:** Push style shifters use a large high amperage solenoid that requires the use of a relay or a starter style solenoid to handle the load. These style solenoids use voltage to push the shift lever and make the gear change. **You MUST use a relay or starter solenoid to avoid damage to the CC-3.** **SET SHIFTER TYPE TO "AIR" SHIFTER**

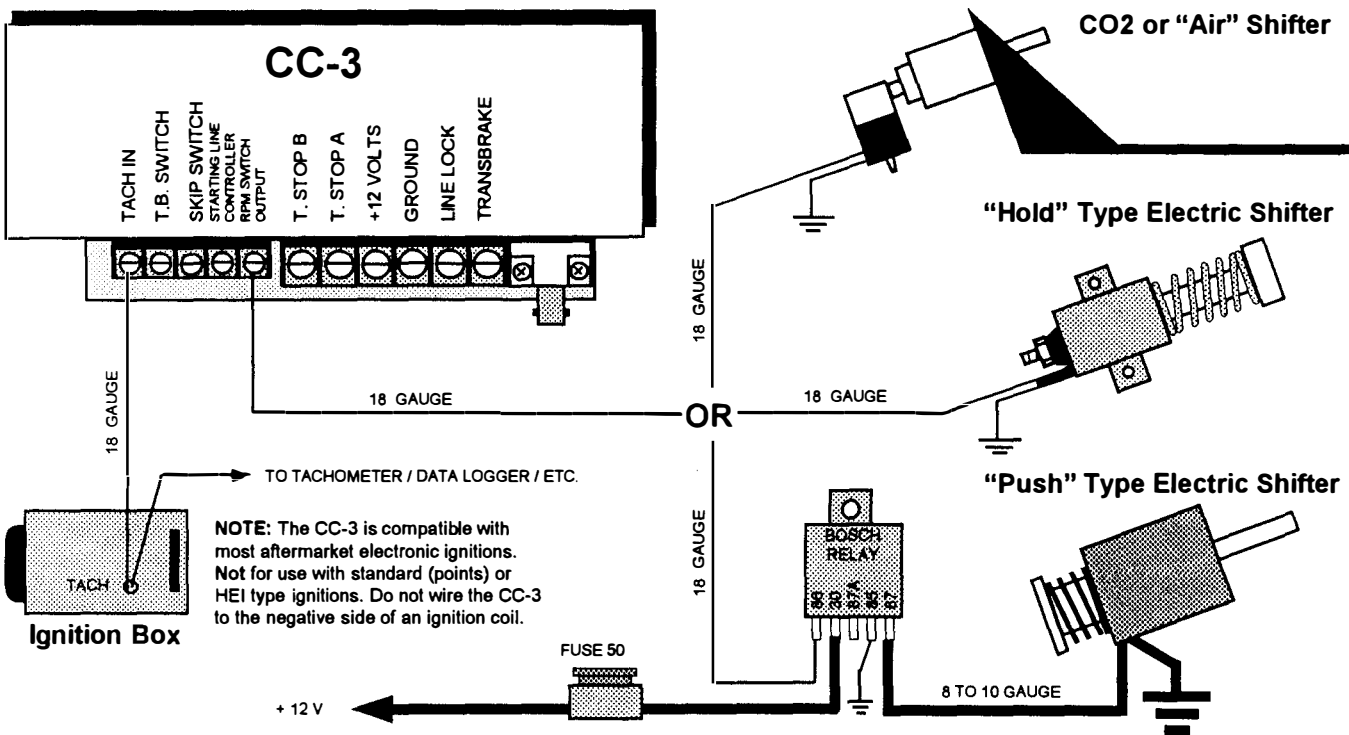

WIRING FOR REMOTE DISPLAY

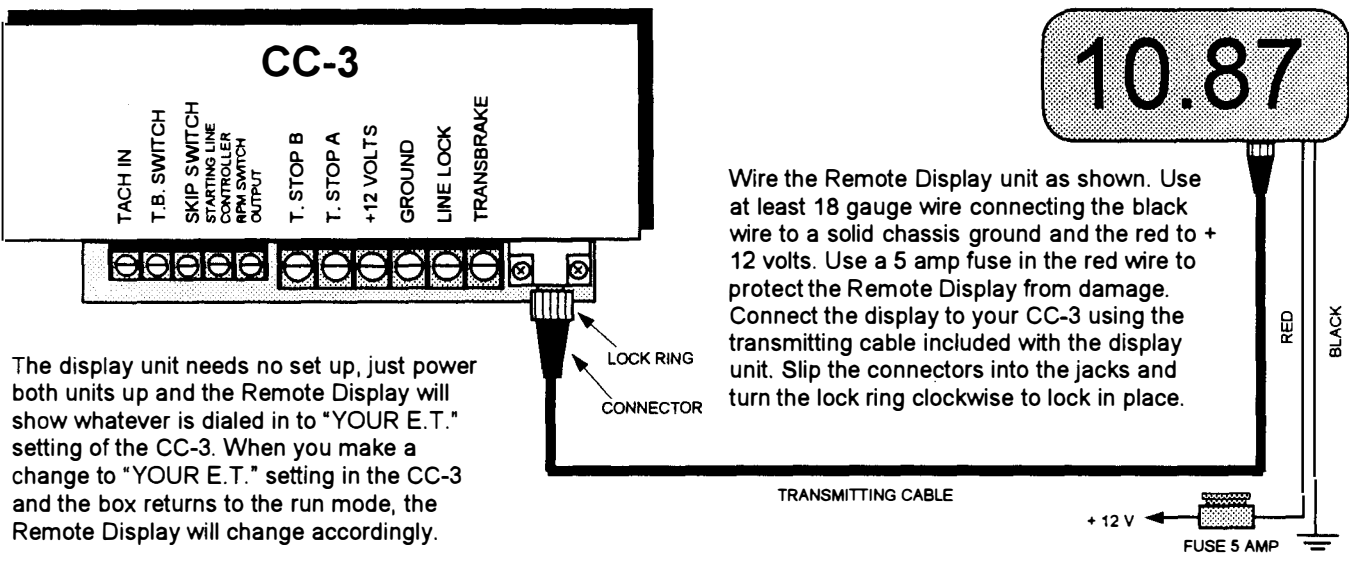

FACTORY SETTINGS AND PARAMETERS

PRO-FULL SETTING PARAMETERS: PRO MODE = P/F LIGHT ON FULL MODE = P/F LIGHT OFF			FACTORY SETTINGS	
ACCESS BUTTON	SETTING	RANGE	PRO	FULL
↑ TBRK ↓	DELAY	0.000 to 1.999 sec.	.010	1.000
	DELAY 2	0.000 to 1.999 sec.	.010	.500
	THEIR E.T.	00.00 to 19.99 sec.	10.90	10.00
	YOUR E.T.	00.00 to 19.99 sec.	9.90	9.00
	BOTTOM DELAY	0.00 to .299 sec.	.010	.100
	CROSS COMP	.000 to .099 sec.	.015	.015
	SKIP UP / SKIP DOWN	+.050 to -.050 sec.	-.010	-.010
	TB PAUSE	0.000 to 1.999 sec.	.010	.010
	TB LOCK OUT	00 to 19 seconds	01	03
	TBRK			
↑ STOP A ↓	THROTTLE STOP A, TIMER 1	0.000 to 9.999 sec.	.300	1.000
	THROTTLE STOP A, TIMER 2	0.000 to 9.999 sec.	1.500	2.000
	THROTTLE STOP A, TIMER 3	0.00 to 19.99 sec.	3.00	3.00
	THROTTLE STOP A, TIMER 4	0.00 to 19.99 sec.	3.00	3.00
	THRTTL STP TYP A	Baseplate or Linkage	BASE	BASE
STOP A	SLC START LINE CONTROL	TB Release, Timed, Prestage, Off	OFF	TIMED
↑ STOP B ↓	THROTTLE STOP B, TIMER 1	0.000 to 9.999 sec.	1.500	1.000
	THROTTLE STOP B, TIMER 2	0.000 to 9.999 sec.	2.000	2.000
	THROTTLE STOP B, TIMER 3	0.00 to 19.99 sec.	3.00	3.00
	THROTTLE STOP B, TIMER 4	0.00 to 19.99 sec.	3.00	4.00
	THRTTL STP TYP B	Baseplate or Linkage	BASE	BASE
STOP B				
↑ RPM ↓	THROTTLE STOP C, TIMER 1	0.000 to 9.999 sec.	2.000	2.000
	THROTTLE STOP C, TIMER 2	0.000 to 9.999 sec.	2.500	2.500
	THROTTLE STOP C, TIMER 3	0.00 to 19.99 sec.	5.00	5.00
	THROTTLE STOP C, TIMER 4	0.00 to 19.99 sec.	5.00	5.00
	THRTTL STP TYP C	Baseplate or Linkage	BASE	BASE
	1-2 SHIFT RPM	2000 to 9999 RPM	7500	7500
	2-3 SHIFT RPM	2000 to 9999 RPM	7500	7500
	SHIFT DISABLE TIME	0.000 to 3.999 sec.	.500	.500
	SHIFTER TYPE	Air or Electric	ELEC	ELEC
	NUMBER OF CYLINDERS	4, 6, 8 cylinders	8	8
RPM	RPM OR TIMER	2 Speed, 3 Speed, Timer	2 SPD	2 SPD

SERVICE AND WARRANTY

LIMITED 1 YEAR WARRANTY

DEDENBEAR Products, Inc. warrants to the consumer that all DEDENBEAR Products purchased from an Authorized DEDENBEAR Reseller will be free from defects in material and workmanship for a period of twelve (12) months from date of the original purchase. Products that fail within this 12 month warranty period will be repaired or replaced at DEDENBEAR's option, when determined by DEDENBEAR that the product failed due to defects in material or workmanship. This warranty is limited to the repair or replacement of parts in the DEDENBEAR Product and the necessary labor done by DEDENBEAR to effect the repair or replacement of the DEDENBEAR product. In no event shall DEDENBEAR's cost to repair or replace a DEDENBEAR under this warranty exceed the original purchase price of the DEDENBEAR Product. Nor shall DEDENBEAR Products, Inc. be responsible for special, incidental or consequential damages or costs incurred due to the failure of a DEDENBEAR Product. This warranty applies only to the original purchaser of the DEDENBEAR Product and is non-transferable. This warranty also applies only to DEDENBEAR Products purchased from an Authorized DEDENBEAR Reseller. All implied warranties shall be limited in duration to the said 12 month warranty period. Breaking the instrument seal, improper use or installation, accident, water damage, abuse, unauthorized repairs or alterations voids this warranty. DEDENBEAR disclaims any liability for consequential damages due to the breach of any written or implied warranty on all products manufactured by DEDENBEAR Products, Inc.

SERVICE

For service send your product to Dedenbear in a well packed shipping carton. Please include a note explaining what the problem is along with your phone number. If you are sending product back for Warranty adjustment, you must include a copy (or original) of your sales receipt from the place of purchase.

FOR SERVICE SEND TO: DEDENBEAR PRODUCTS, INC. 413 W. Elm St., Sycamore, IL 60178 USA (866) 248-6357

International: (815) 895-8141

Email us at service@autometer.com

<http://www.autometer.com>

2650-1346-00 Rev. B

5/10/18