

# INSTALLATION INSTRUCTIONS

2650-1319-00 Rev. A



413 West Elm Street - Sycamore IL 60178

(866)248-6357 • fax (815)895-6786

[www.autometer.com](http://www.autometer.com) • [service@autometer.com](mailto:service@autometer.com)

## Disc Style Throttle Stop Models TS-6 and TS-6B

### INSTALLATION

- 1) Remove the carburetor, gasket, and mounting studs.
- 2) Install four carb studs of an appropriate length to mount the throttle stop, carburetor, and any spacers / heat shields.
- 3) Install an open or four hole gasket on the intake, any spacers or heat shields, then the throttle stop. The throttle stop can be mounted with the air cylinder on either the driver or passenger side of the motor. If you decide to mount the stop with the cylinder on the passenger side (adjustment hex facing the front of the car), test fit the carb by gently setting the carb on the stop and checking for interference or clearance problems with the fuel lines.
- 4) Find a suitable location to mount the remote solenoid away from high heat (headers, heads, directly on intake, etc.) and mount it with the supplied hardware. The closer to the cylinder, the better. The shorter the air lines, the less volume of CO2 the solenoid has to charge and purge to open and close the throttle stop. Four (4) feet of air line is maximum with 6 inches to 1 foot being ideal. Both lines do not need to be the same length.
- 5) Plumb the air lines to the solenoid per the diagram on the reverse side by trimming to length and pushing the tubing firmly into the the quick disconnect fittings and the needle valves. The tubing can be removed by pushing in the locking ring and pulling on the tubing.
- 6) Connect one wire from each solenoid to a good chassis ground together; try to avoid grounding to aluminum and to tin work. Connect the other wire from each solenoid to the output on your throttle stop controller together, 18 gauge wire is sufficient. On early Dedenbear timers the "N.O." terminal is used, on Model TSC-2A controllers, move the "output" switches down to "OFF-ON-OFF" mode, and if a Model L1, L2, CC1 or CC3 microprocessor style unit is used change the throttle stop output to "LINKAGE/DISC STYLE".
- 7) Turn on your CO2 bottle to charge the lines, set the regulator to 60-80 psi line pressure. Check the system for leaks by turning the bottle off and watching the line pressure. If the pressure drops off more than 5 psi in 10 min., check all of your connections with soapy water for leaks. Turn the bottle back on.
- 8) Cycle the throttle stop timer by activating the transbrake. Visually watch the disc stop open and close to ensure it moves freely and that the wiring and plumbing is complete and correct.
- 9) A four hole gasket is recommended between the throttle stop and the carburetor, and any open spacers or gasket should be avoided between the carb and throttle stop.
- 10) Reinstall the carburetor, fuel lines, carb linkage and air pan / air cleaner.

### OPERATION

- 1) The disc stop's closed throttle position is adjusted by holding the long hex adjustment nut with a 1/2" wrench, breaking the locknut loose with a 7/16" wrench, and threading the adjustor hex in or out. **BE VERY CAREFUL NOT TO BEND THE SHAFT THAT THE ADJUSTMENT HEX RIDES ON.** If the shaft gets bent the throttle stop will bind, stick or jam up. Threading in (hex closer to the air cylinder) will increase the opening size (raising RPM while on the stop) and threading out (away from the air cylinder) will decrease the opening size (lowering RPM while on the stop). Make sure to tighten the locknut after adjustments.
- 2) The wide open throttle position is not adjustable. When the stop is not activated it is wide open.
- 3) For best adjustability of the needle valves, recommended air pressure from the regulator is 60-80 psi line pressure.
- 4) The air cylinder has two needle valve adjusters on it. (See diagram on back.) These are the adjustments for the opening and closing rate of the air cylinder. Carefully turn both of these all the way in (clockwise) until they bottom out, then slowly back them out about 3 to 4 turns. Opening the needle valves (counter-clockwise) increases the speed of the air cylinder and closing (clockwise) slows the speed. Once the opening and closing rates are set, lock the needle valves in position using the small locking rings.

---

NOTE: A Second Stage Kit is available for your TS-6 Disc Stop. This is a retrofit kit that will change this throttle stop into a dual stage stop, allowing 2 different "closed" throttle positions, and with the addition of a second throttle stop controller will permit progressive throttle closing and opening, i.e., launch wide open, 0.20 sec. close to 1/2 throttle, 0.40 sec. close to 1/4 throttle, 2.00 sec. back to 1/2 throttle, 2.50 sec. back to wide open. **PART # TS6SSK**

---

## AIR SOLENOID WIRING

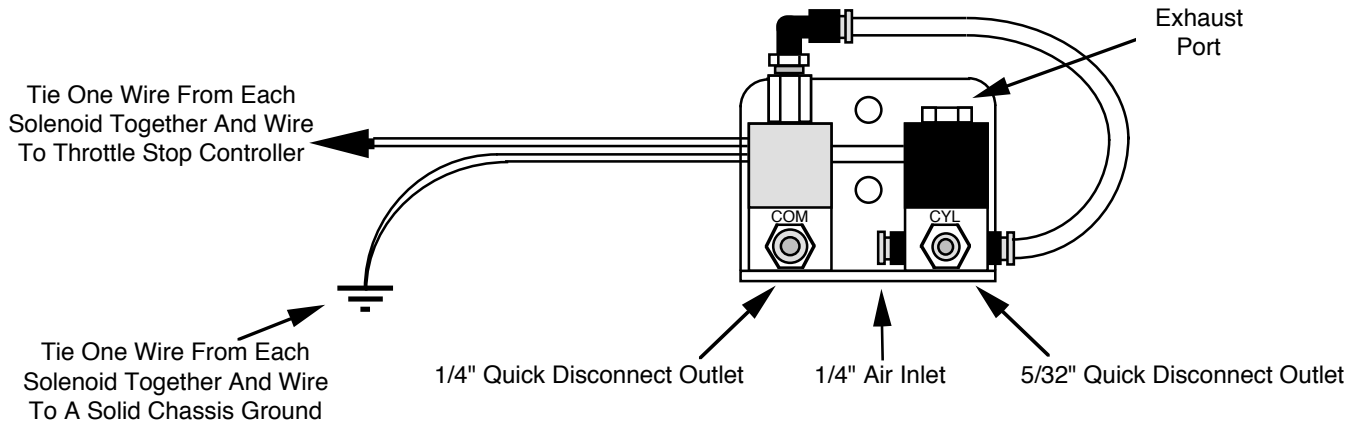

## AIR SOLENOID PLUMBING

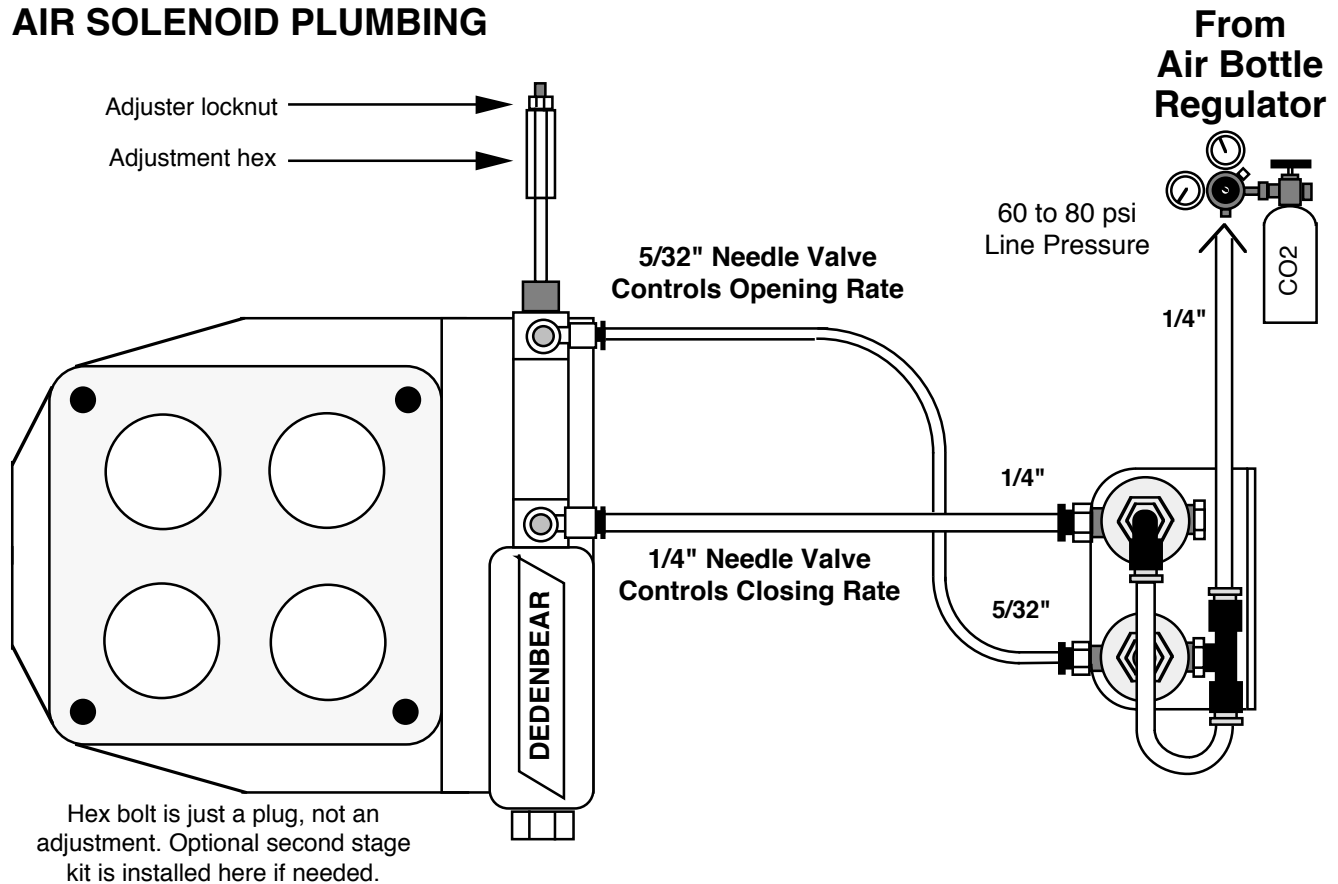

## LIMITED 1 YEAR WARRANTY

DEDENBEAR Products, Inc. warrants to the consumer that all DEDENBEAR Products purchased from an Authorized DEDENBEAR Reseller will be free from defects in material and workmanship for a period of twelve (12) months from date of the original purchase. Products that fail within this 12 month warranty period will be repaired or replaced at DEDENBEAR's option, when determined by DEDENBEAR that the product failed due to defects in material or workmanship. This warranty is limited to the repair or replacement of parts in the DEDENBEAR Product and the necessary labor done by DEDENBEAR to effect the repair or replacement of the DEDENBEAR product. In no event shall DEDENBEAR's cost to repair or replace a DEDENBEAR under this warranty exceed the original purchase price of the DEDENBEAR Product. Nor shall DEDENBEAR Products, Inc. be responsible for special, incidental or consequential damages or costs incurred due to the failure of a DEDENBEAR Product. This warranty applies only to the original purchaser of the DEDENBEAR Product and is non-transferable. This warranty also applies only to DEDENBEAR Products purchased from an Authorized DEDENBEAR Reseller. All implied warranties shall be limited in duration to the said 12 month warranty period. Breaking the instrument seal, improper use or installation, accident, water damage, abuse, unauthorized repairs or alterations voids this warranty. DEDENBEAR disclaims any liability for consequential damages due to the breach of any written or implied warranty on all products manufactured by DEDENBEAR Products, Inc.

FOR SERVICE SEND TO: **DEDENBEAR PRODUCTS, INC** 413 W. Elm St. Sycamore, IL 60178 USA (866) 248-6357

Email: [service@autometer.com](mailto:service@autometer.com)