



DEDENBEAR®

LIGHTNING and LIGHTNING PLUS
INSTALLATION & OPERATION MANUAL

INDEX

Installation Instructions	pg 1	Starting Line Control / Super Start	pg 6
Pro/Full Feature	pg 2	General Info / Definitions	pg 7
Button Use & Programming	pg 2	Transbrake Wiring	pg 8
Types of Delay Boxes	pg 3	Throttle Stop & Nitrous Wiring	pg 9
Setting Transbrake Delay	pg 3-4	Linkage Stop & Remote Display	pg 10
Setting Throttle Stop Types & Timers	pg 4-5	Timed Shifter Wiring	pg 11
Throttle Stop Control	pg 5	Setting Parameters	pg 12

INSTALLATION

Using #8 screws through the rubber grommets in the base, mount the **LIGHTNING** away from heat, vibration and the ignition system.

Make sure the driver can reach the buttons when strapped in and angle the unit, if needed, so the display can be read straight on.

Wire the **LIGHTNING** as shown on pages 8-11. Make sure the power lead comes straight from the master switch and the ground goes to a solid chassis ground, not sheet metal panels.

BUTTON QUICK REFERENCE

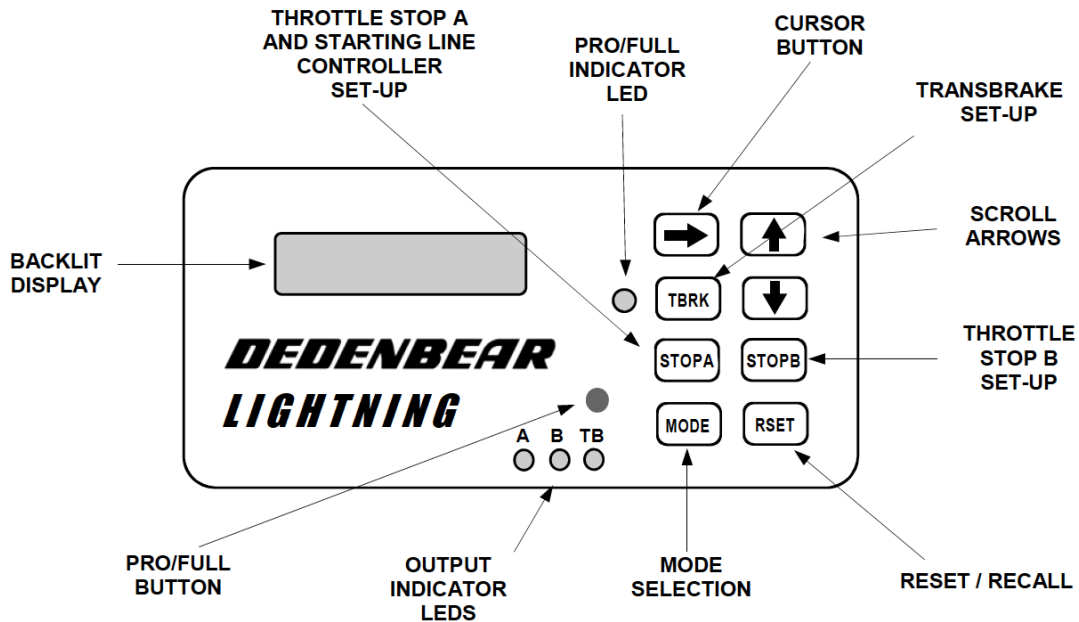

BUTTON USE AND SETTINGS

The **LIGHTNING** has many selections that can be programmed for each setting. Each time you push the button for the particular setting you are adjusting, it will step you to the next prompt screen. The **LIGHTNING** will only ask for the settings needed for the particular mode you are in. For example, when adjusting settings for throttle stop A, the **LIGHTNING** will not ask for the settings for your transbrake delay. At each prompt screen you can change a setting by using the scroll buttons or the cursor. If no adjustment is needed for a setting, press the button again to step to the next screen. After your adjustments are made, the **LIGHTNING** automatically returns to the run mode after 8 seconds.

PRO/FULL BUTTON

The **LIGHTNING**'s **PRO/FULL** feature allows you to switch between two complete setting groups for the delay box and throttle stop features. This enables you to program the box for your "Super" class settings in **PRO**, and then program your bracket race settings in **FULL**. Now when you switch between classes, you no longer need to reprogram the **LIGHTNING**, just push and hold the **PRO/FULL** button to switch between groups of settings. The red



LED indicator light to the left side of the keypad will indicate which setting group you are in. When you are in the **PRO** group, the **PRO/FULL** LED will turn on and stay on. When you are in the **FULL** group, the LED will be off.

P/F



REMEMBER: It is extremely important when you change a setting that you are in the setting group (PRO or FULL) in which you want the change to occur since each group has it's own complete set of settings

PROGRAMMING BUTTONS



Arrow (scroll) Buttons: These buttons are used for making small changes to your settings. You can add to a setting by pressing the up arrow, or subtract with the down. If you push and hold an arrow key, the setting will continue to change faster and faster.



Cursor Button: This button allows you to change each digit individually. This makes large number changes much quicker than just using the scroll. When you push the cursor button the first time, a cursor appears under the left most digit. Each press of the cursor button thereafter moves the cursor one digit to the right. Stop the cursor under the digit you wish to change and use the arrow (scroll) buttons to change that digit up or down. Pressing the cursor button one more time after the cursor is under the right most digit will remove the cursor from the screen and return the arrow buttons to regular scrolling action.



TBRK Button: This button accesses your Transbrake settings. Each time you press the TBRK button, different set-up screens come up and allow you to make changes to your Delay, Delay 2, Your ET, Their ET, Bottom Delay, Cross Comp, Skip Up/Down, TB Pause, & TB Lockout settings.



STOPA Button: This button accesses your Throttle Stop Controller A and the Starting Line Controller settings. Each time you press the STOP A button, different set-up screens come up and allow you to make changes to your 4 Timer settings (timer A1 to A4) and your Starting Line Controller settings.



STOPB Button: This button accesses your Throttle Stop Controller B settings. Each time you press the STOP B button, different prompt screens come up and allow you to make changes to your 4 Timer settings (timer B1 to B4).



MODE Button: This button selects which of the 4 delay box modes you wish to run. They are Delay, Crossover, Interface and Cross Talk.



RSET Button: This button is used for setting the box for the type of equipment it will be running, i.e., Throttle Stop Type, Starting Line Control, etc. Press and hold the RSET button to make the change. This button also can be used to cancel the throttle stop timers during the pass and recalls information about the run after the pass has been made.

DELAY BOX TYPES

The LIGHTNING has four different types of delay boxes built in. They are:

1. **DELAY:** A simple 4 digit delay box used for pro tree classes and leaving off your top amber for full tree classes. The box simply delays for the time set and releases the transbrake.
2. **CROSSOVER:** Used in full tree bracket racing for launching off your opponents top bulb when you are the faster car. The box calculates the handicap and adds it to your delay time.
3. **INTERFACE:** This is used the same as crossover except it allows you to take two hits at the tree. You leave off the opponent's top bulb, press the transbrake button again, then release off your own top bulb. The box will release the transbrake on the quicker of the two releases. This means if your release on the opponent's top bulb gives you a .520 light and the release on your top bulb gives you a .505 light, the box will launch the car on the .505 light. Remember, the interface always chooses the quicker light and will choose a .490 over a .500.
4. **CROSS TALK:** Used for the cross talk bracket tree, this mode functions the same as the Interface mode except it allows you to take two hits at your tree, one off your top amber, and one off your second amber. Like the Interface, the box will choose the quicker of the two reaction times.

To change between the delay box types, press the MODE button. Continue until the mode you want appears.

SETTING TRANSBRAKE DELAY

To set your transbrake delay you must first choose which delay box type you wish to run by pressing the MODE button. The LIGHTNING will only ask for the settings required for that particular mode. Example: When you are in RUN (DELAY) it will not ask you for THEIR ET setting since you are not crossing over. All of the shared settings between these modes will transfer when you change to a different mode. Example: Your delay setting will transfer over to all four different delay box modes along with your SKIP, TB PAUSE, and TB LOCK OUT settings.

To set your transbrake delay you must first choose which delay box type you wish to run by pressing the MODE button. The LIGHTNING will only ask for the settings required for that particular mode. Example: When you are in RUN (DELAY) it will not ask you for THEIR ET setting since you are not crossing over. All of the shared settings between these modes will transfer when you change to a different mode. Example: Your delay setting will transfer over to all four different delay box modes along with your SKIP, TB PAUSE, and TB LOCK OUT settings.

THEIR ET	YOUR ET	DELAY
10.00	9.00	1.000
RUN (INTERFACE)		

RUN SCREEN: This is the screen the **LIGHTNING** will display when it is "ready to run". It will always display YOUR ET and your DELAY. When in Crossover, Interface and Cross Talk modes it will also display THEIR ET.

NOTE: If you are not using the remote display dial-in board (part# RD-1) the YOUR ET setting is not important when in the DELAY mode. This setting will not effect your delay time whatsoever.

TBRK

Press the **TBRK** button to enter the transbrake adjust settings menu. Each time you press this button it will advance to the next set-up screen. Once you have advanced through all of the screens, the box returns back to run mode. When you are through making adjustments to the settings, the box will automatically return to the run mode in 8 seconds.

SETUP MODE
DELAY 1.000

DELAY: When you first press the TBRK button, the delay setting will appear. Use the scroll arrows or the cursor button to change this setting. For leaving off the top bulb on a full tree, this setting is typically around 1.000 second.

SETUP MODE
DELAY2 .500

DELAY2: This screen will appear next only in Cross Talk mode (not needed in Delay, Crossover or Interface). Delay 2 is the amount of delay used for taking a 2nd hit at the 2nd amber bulb on a Cross Talk bracket tree. Typical 2nd amber delay setting is around .500 second. Use the scroll arrows or cursor button to change this setting.

SETUP MODE
THEIR ET 10.00

THEIR ET: This is the next screen that will appear in Interface, Crossover and Cross Talk modes (not needed in Delay mode). Use the scroll arrows or cursor button to change this setting to your opponent's dial-in.

SETUP MODE
YOUR ET 09.00

YOUR ET: This is where you enter your own vehicle's dial-in. Use the scroll arrows or cursor button to make changes. If you run a Remote Display dial-in board, this is the setting that will be displayed upon return to run mode.

SETTING TRANSBRAKE DELAY (continued)

SETUP MODE
BOT DELAY 100

BOT DELAY: Bottom bulb delay time is the amount of delay you need for a bottom bulb release on a full tree when using the “Last Chance” feature while in Interface and Cross Talk modes. Adjust with scroll or cursor button

SETUP MODE
CROSS COMP .015

CROSS COMP: Crossover compensation time is used to compensate for late lights when crossing over. When you cross over and leave off your opponent’s tree, you get an indirect view of his top bulb instead of a direct view like on your side. This results in a reaction time that is about .010 to .020 seconds slower. Crossover compensation automatically subtracts this time from your delay setting whenever you crossover. Use the scroll arrows or cursor button to change this setting. **NOTE: Cross comp should be set for 0.000 when running on a Cross Talk bracket tree.**

SETUP MODE
SKIP DOWN :015

SKIP DOWN or SKIP UP: This is the amount of time you want to add (Skip UP) or subtract (Skip Down) from your delay time after you have released the transbrake button. If you feel you “missed” the tree, every time you push the skip button the box will add or subtract this amount from your delay time. Use the scroll arrows to change this setting.

SETUP MODE
TB PAUSE 100

TB PAUSE: This is the amount of time the box pauses from when the transbrake button is depressed until the transbrake sets. This prevents transbrake application if the button is accidentally bumped or brushed while driving down the return road or in the staging lanes.

SETUP MODE
TB LOCKOUT 03

TB LOCK OUT: This is the amount of time the box will lock out the transbrake so the driver can not re-apply the transbrake during the pass. Use the scroll arrows or cursor button to change the lock out in increments of whole seconds.

THROTTLE STOP TIMERS

The **LIGHTNING** has 2 separate throttle stop controller outputs, the **STOP A** and the **STOP B** output. The **STOP A** output has a shared starting line control (SLC) output while the **STOP B** is simply a timer. Both outputs work independently from one another allowing control over two separate devices.

The **STOP A** output can be used as a 2-stage timer, 4-stage timer or a starting line control. It can also be used as a combined 2 or 4-stage timer and starting line output for using the same throttle stop for starting line and down track use. To use the **STOP A** / SLC output for down track timing only (no starting line control) you must turn the start line control setting to **OFF**. See page 6 for details.

The **STOP B** output can be used only as a 2-stage timer or a 4-stage timer.

Either of the throttle stop outputs can be used to time just about any 12 volt device. Besides throttle stops, common uses are timed shifts, nitrous systems, ignition retards, lean outs, etc. The **STOP A** / SLC and **STOP B** outputs are rated at 15 amps each.

STOP A

STOP B

To set your throttle stop timers, press the **STOP A** or **STOP B** button to enter each of the respective timer menus. Each time you press the button it will advance to the next set-up screen. The procedure is the same for changing settings as in the TBRK menu. After advancing through all the screens, or after 8 seconds without making a change, the box returns to run mode.

THROTTLE STOP TIMERS (continued)

A1: 1.000
A2: 2.000

2-Stage summary screen

A1: 1.000 A3 3.00
A2: 2.000 A4 3.00

4-Stage summary screen

The first screen that will be displayed is a summary screen that shows you all of your throttle stop timer settings for quick reference. If you are using a 2-stage timer only two settings will appear, and if a 4-stage timer is being used all 4 timers will be displayed. If the Throttle Stop Control is turned OFF there will be no summary screen. Note that the timers are preceded with a letter. A1 represents Stop A timer 1, B3 would be Stop B timer 3. Like all the other prompt screens, this screen will disappear and return to run mode after 8 seconds.

In this example, notice how timer A2 is set higher than A1, and A3 & A4 are set the same. All the timers must be set sequentially larger, meaning timer 2 must be equal to or larger than timer 1, timer 3 must be equal to or larger than timer 2 and timer 4 must be set equal to or larger than timer 3. If you accidentally set a timer lower than the previous timer, the "STOP A SET WRONG" error message will appear. Reset the timers in proper sequence to eliminate the error. Also know that when timer 1 & 2 or timer 3 & 4 are set the same as one another, they will cancel each other out and the output will not change.

SETUP T-STOP A
A1: 1.000 SECONDS

The set-up screens following the summary screen are where you change your throttle stop timers. Use the scroll arrows or the shift button to make changes. All the throttle stop timers start timing at release of the transbrake solenoid. So if you had 1.000 in timer 1, 2.000 in timer 2, 3.00 in timer 3 and 3.00 in timer 4, the car would launch at wide open for 1 second, the throttle stop would close for 1 second (duration = timer 2 minus timer 1) and then go wide open for the remainder of the pass (timer 3 & 4 cancel each other out). Please note that timers 1 & 2 are adjustable to the thousandth of a second and timers 3 & 4 are adjustable to the hundredth.

T-STOP A TYPE
BASE PLATE STYLE

The following set-up screen in the throttle stop menu is where you can change your throttle stop type. Press and hold the **RSET** button while this screen is up to change from "BASE PLATE STYLE" to "LINKAGE / DISC" or vice versa. This changes the output polarity to correctly run whatever device you've wired to the output.

Typical devices and the correct setting or "type":

- Under the carb "Butterfly" throttle stops use : BASE PLATE STYLE (power turns off at timer 1)
- Under the carb "Disc" throttle stops use: LINKAGE / DISC (power turns on at timer 1)
- In-line "Linkage" throttle stops use: LINKAGE / DISC (power turns on at timer 1)
- Nitrous Oxide systems use: LINKAGE / DISC (power turns on at timer 1)
- Dedenbear Solenoid Shifter "Hold type" use: BASE PLATE STYLE (power turns off at timer 1)
- CO2 or "Air" shifters use: LINKAGE / DISC (power turns on at timer 1)

T-STOP A CONTROL
2-STAGE

The last prompt screen that will be displayed is the throttle stop control. To change the type of control, push and hold the **RSET** button while the screen is showing. There are three control settings:

2-STAGE: A two stage timer allows you to cycle the throttle stop once down track. Timer 1 is the time from launch until the throttle stop turns on, and timer 2 is the time from launch until the stop comes back to wide open throttle.

T-STOP A CONTROL
4-STAGE

4-STAGE: A four stage timer allows you to cycle the throttle stop twice down track. Timer 1 is the time from launch until the throttle stop turns on, and timer 2 is the time from launch until the stop comes back to wide open throttle. Timer 3 will shut the stop down a second time down track, and timer 4 will bring the throttle stop back to wide open.

T-STOP A CONTROL
TURNED OFF

OFF: In the off position the throttle stop output will not cycle. This setting is used when a wide open pass is to be made, or when the Starting Line Control feature is to be used without the throttle stop functioning down track.

STARTING LINE CONTROL & SUPER START SYSTEM

**STOP
A**

Starting Line Control (SLC) is a shared output with **STOP A**. This output can be used to control a single throttle stop as a down track to control the E.T., a starting line control to control the staging RPM, or both. If a single throttle stop is used for both starting line and down track duties the staging RPM must be the same as the down track RPM. To use the **STOP A / SLC** output as just a starting line control, simply change the **STOP A CONTROL** setting to **OFF**. To use the **STOP A / SLC** output as just a down track control, simply change the **START LINE CONTROL** setting to **OFF**. The starting line control settings are accessed through the **STOP A** menu. There are 4 different SLC options (see below for individual descriptions). This output is wired to a linkage style throttle stop to control your staging **RPM** in various ways. Press and hold the **RSET** button to flip through these options. The Super Start System is a feature that allows you to activate your Starting Line Control **BEFORE** you stage the vehicle by momentarily pressing the skip switch allowing you to stage with your foot on the floor. The optional skip switch must be wired in to use this feature. The Super Start works differently in each of the SLC modes, see below for specific functions.

START LINE CNTRL
TBRAKE RELEASE

SLC Transbrake Release functions as follows: At application of the transbrake (when you press the transbrake button) the linkage stop will close your throttle. At transbrake solenoid release (launch) the linkage stop will pull the throttle wide open. If you wish, the Super Start can be used in this mode also. Momentarily press the Skip Button prior to staging the car and the linkage stop will close right then so you can stage the car with your foot on the floor. The linkage stop will still pull wide open at transbrake release.

START LINE CNTRL
TIMED : 1.000

SLC Timed functions as follows: At application of the transbrake (when you press the transbrake button) the linkage stop will close your throttle. At the predetermined time (whatever is set in this set-up screen) **BEFORE** transbrake solenoid release (launch) the linkage stop will pull the throttle wide open. Using this feature will allow you to have the car come up against the converter or 2-step for exactly the same amount of time every pass whether you are crossing over or launching off your tree. If you wish, the Super Start can be used in this mode also. Momentarily press the Skip Button prior to staging the car and the linkage stop will close right then so you can stage the car with your foot on the floor. The linkage stop will still pull wide open at the predetermined time before transbrake release.

START LINE CNTRL
PRESTAGE

SLC Prestage functions as follows: In this mode you must activate the Super Start System prior to staging by momentarily pressing the Skip Button to have the linkage stop close your throttle. At activation of the transbrake solenoid (when you press the transbrake button) the throttle will immediately pull to wide open so the motor will come up against the converter or 2-step for the entire staging duration. This mode is primarily used in pro-tree classes with short staging durations but it can be used with a full tree if desired

START LINE CNTRL
TURNED OFF

SLC Turned Off: If you wish to run without the aid of your Starting Line Control you can simply turn the output off. In this mode the SLC will do nothing. The off setting is also used when the **STOP A / SLC** output terminal is to be used to control a down track throttle stop only.

GENERAL INFORMATION AND DEFINITIONS OF FEATURES

Reset/Recall Button: Used to change the settings for the type of equipment on your car. For example, the type of throttle stop, how you want the starting line controller set up, etc. To use it for these applications, go to the set-up screen for the feature you wish to change, press and hold the **RSET** button until the box changes its set up. If pressed during a pass, the **RSET** button will cancel the throttle stop timers and return to a ready to run condition. If pressed after the run, the **RSET** button will recall the "How Late" information and how many times you "Skipped".

ARP (Accidental Release Protection): Occasionally you may anticipate the lights and release the button too early. **ARP** lets you recover from this situation. In Delay and Crossover modes, you simply press the transbrake button again before the car launches and the **LIGHTNING** will instantly reset itself. In Interface and Cross Talk modes this does not work because the **LIGHTNING** is expecting a second hit. To avoid a red light you can use the Last Chance feature.

Last Chance: This feature works only in Interface and Cross Talk modes. If you think either or both of your releases were too quick, press the transbrake button down a third time to cancel the first two hits, then release the button off your bottom bulb to launch the car. If your car red lights off the bottom bulb, add some time to the Bottom Bulb delay and the Last Chance feature will use the delay from that setting.

How Late: In the Interface and Cross Talk modes where you can take two hits at the tree, the How Late feature tells you which of the hits was faster and by how much. In Interface mode the How Late timer will display "THEIR TREE BY: .XXX" or "YOUR TREE BY: .XXX" or "LAST CHANCE ACTIVATED". As an example, if you were in Cross Talk mode, the display might read "FIRST HIT BY: .023". This means that you were quicker leaving off your top bulb than your second bulb and that you were .023 seconds quicker. The **LIGHTNING** released the transbrake off the top bulb hit in this example. If you had cancelled the first two hits by pressing the button a third time, the display would read "LAST CHANCE ACTIVATED". After a run is made, the How Late information is recalled by pressing and holding the **RSET** button. The display will alternate between the How Late information and the number of Skips.

Skip Recall: Skip Recall tells you the number of times you pressed the **Skip** button during the delay box time out. By checking the set up menu you can determine how much time each Skip was and whether it added or subtracted time to the delay setting. By multiplying the Skip time by the number of Skips, you can calculate the total amount of time that was added or subtracted from your delay time. The number of Skips used can be recalled after the run by pressing and holding the **RSET** button. The display will alternate between the How Late information and the number of Skips.

Throttle Stop Settings Incorrect: If a throttle stop timer is accidentally set lower than the preceding timer (timer 2 set lower than timer 1 or timer 3 set lower than timer 2, etc.) this message will appear. Change the timers to correct the problem. If the run is made without fixing the problem, the affected timer will not cycle (if the timer is running a throttle stop the car will run wide open).

Dial-ins Incorrect: If the Their E.T. setting is accidentally set lower than Your E.T. this message will be displayed. If you make a pass without fixing the problem, the **LIGHTNING** will assume the handicap is zero and will only use the delay setting. Line Lock Output: The Line Lock Output is exactly the same as the Transbrake Output except that it is diode protected. This means that if wired in (see page 8) the delay box will operate the line lock on the starting line, but the line lock will not back feed to the transbrake solenoid while doing a burnout.

Leaving Set Up Menus, Four Ways To Leave:

- 1) Do nothing and the unit will return to the run mode automatically after 8 seconds.
 - 2) Press the Transbrake button and the unit will instantly return to run mode.
 - 3) Clock through the set up menu by repeatedly pushing the setting button until you get back to run mode.
 - 4) Change set up modes (i.e. in the Transbrake set up, you can press the **STOP A** button and jump directly to the set up menu for **STOP A**, etc.)
-

Memory: The microprocessor in the **LIGHTNING** will remember all of your settings, even after turning off the power. There are no internal batteries to die, so the unit will keep your last settings forever.

Battery Chargers: It is important to make sure to have your master disconnect switch off while hooking up your charger between rounds. When the first contact is made between the charger and the battery there may be a voltage spike that could damage electronics. After the charger is hooked up, the master switch can be turned back on to run the water pump, fan, etc.

Temperature: If the **LIGHTNING** ever gets over 160 degrees, the display will get dark and unreadable. This does not damage the unit, simply cool it off and the display will return to normal.

WIRING FOR BASEPLATE STYLE THROTTLE STOPS

For electric "butterfly" throttle stops, set Stop A to "BASEPLATE TYPE".

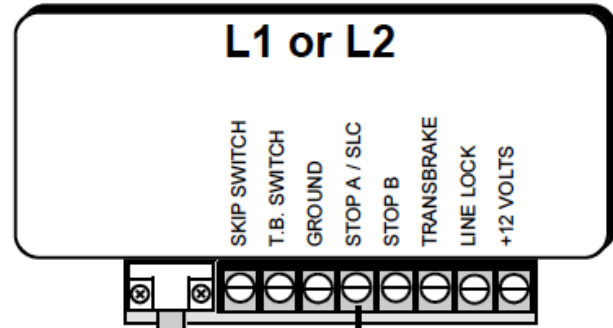
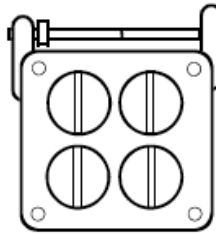

For air "disc" throttle stops, set Stop A type to "LINKAGE / DISC".

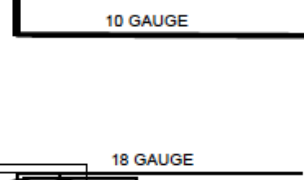
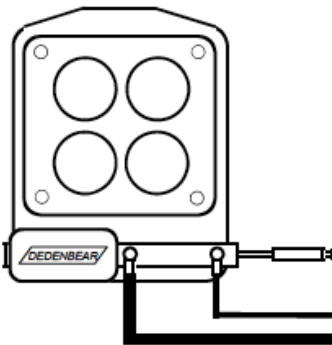

OR

Use 10 gauge wire for electric throttle stops and 18 gauge for air throttle stops.

WIRING FOR 2 STAGE NITROUS SYSTEM

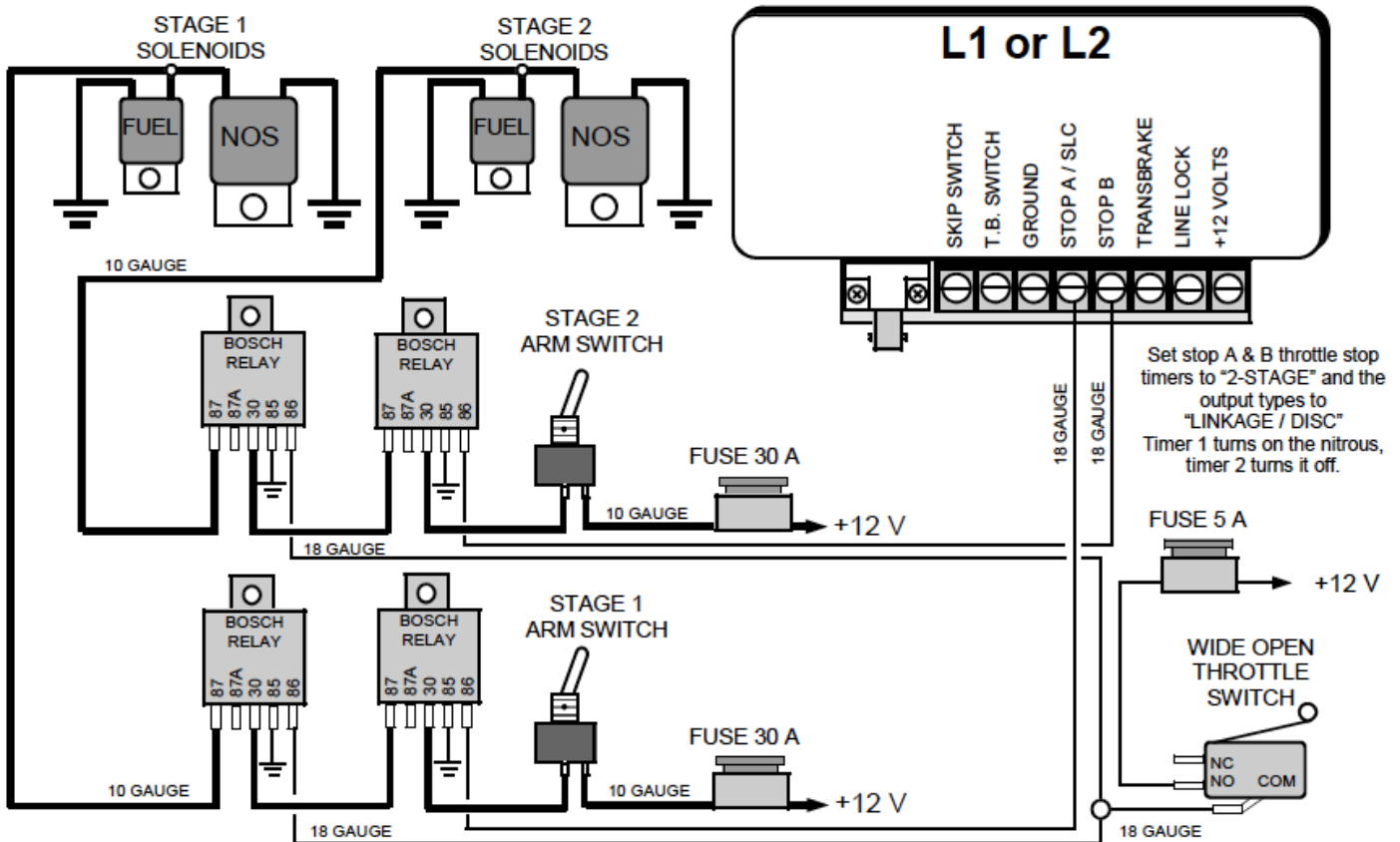

WIRING FOR 2 STAGE NITROUS SYSTEM

There are 3 different ways to use a linkage style throttle stop. They are wired the same.

1. Starting Line Control: In this application the linkage stop closes on the starting line when the transbrake is applied (or prior to staging if the pre-stage feature is activated). This is to control the staging RPM of the engine. See page 6 for a complete description of starting line control options. To use the **STOP A/SLC** output only as a Starting Line Control, turn the **T-Stop A Control** to **OFF** (see page 5).
2. Down Track E.T. Control: In this application the linkage stop is used only during the pass to control the vehicle's elapsed time. Typically racers will close the throttle stop a fraction of a second into the pass and reopen the throttle a few seconds later to slow a car for a particular index. To use the **STOP A/SLC** output only as a Down Track E.T. Control, turn the Start Line Control to OFF (see page 6).
3. Both Starting Line & Down Track Control: This last application allows a racer to use the linkage stop for controlling staging RPM and again during the pass to control the E.T

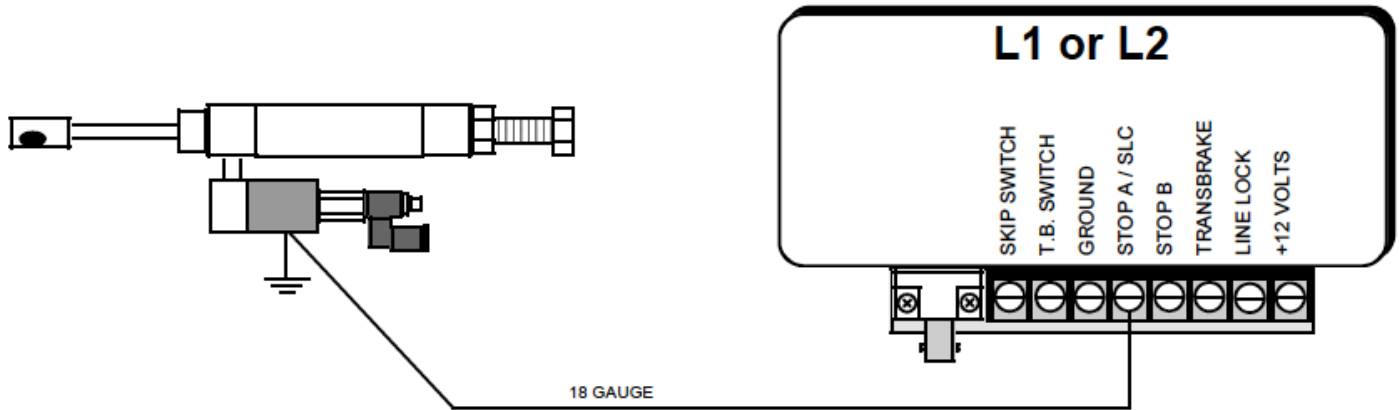

WIRING FOR REMOTE DISPLAY

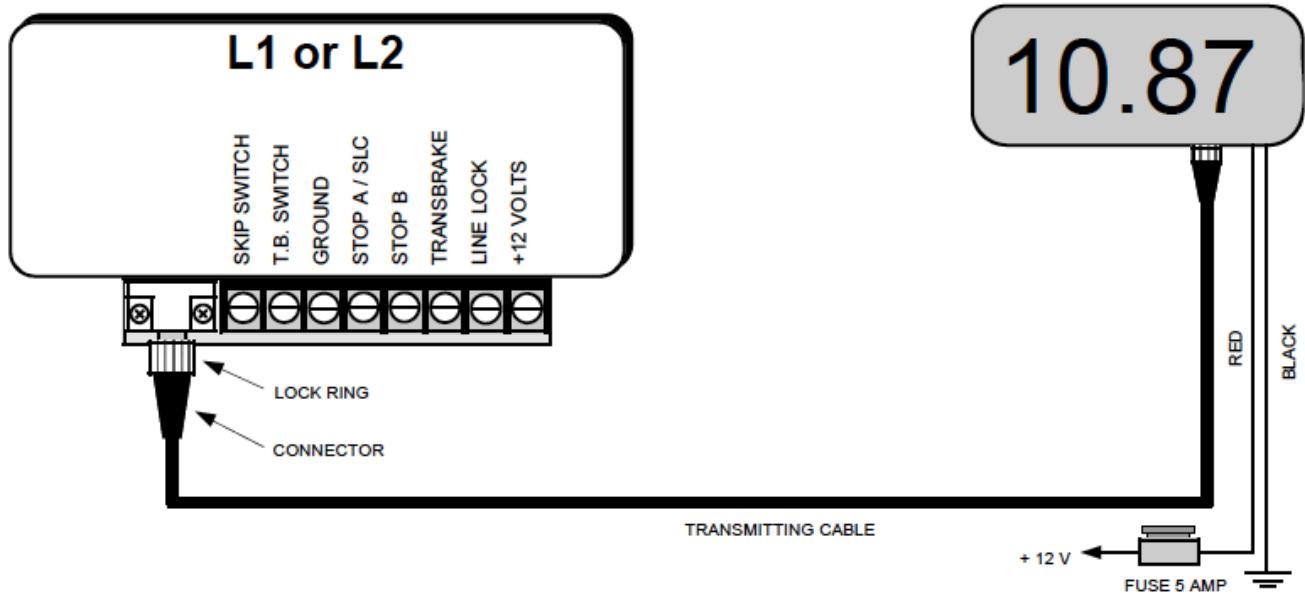

Wire the Remote Display unit as shown. Use at least 18 gauge wire connecting the black wire to a solid chassis ground and the red to + 12 volts. Use a 5 amp fuse in the red wire to protect the Remote Display from damage. Connect the display to your **LIGHTNING** using the transmitting cable included with the display unit. Slip the connectors into the jacks and turn the lock ring clockwise to lock in place. The display unit needs no set up, just power both units up and the Remote Display will show whatever is dialed in to "YOUR E.T." setting of the **LIGHTNING**. When you make a change to "YOUR E.T." setting in the **LIGHTNING** and the box returns to the run mode, the Remote Display will change accordingly.

WIRING FOR TIMED SHIFTING

The **STOP B** output can be wired to an automated shifter for timing your shift.

There are 3 different types of automated shifters commonly used in drag racing. They are:

1. **CO2 or "Air" Shifter:** Air shifters require +12 volts to be applied to fire the shifter and make the gear change. Set **STOP B** to "**2-STAGE**" and the type to "**LINKAGE / DISC**"
2. **"Hold" Type Electric Shifter:** Hold type shifters such as Dedenbear models SS-2, 3, 4, 5, & 6 require a constant +12v to hold the plunger back. At the shift point +12v is removed and the spring pushes the shifter forward. Set **STOP B** to "**2-STAGE**" and the type to "**BASEPLATE**"
3. **"Push" Type Electric Shifter:** Push style shifters use a large high amperage solenoid that requires the use of a relay or a starter style solenoid to handle the load. These style solenoids use voltage to push the shift lever and make the gear change. You **MUST** use a relay or starter solenoid to avoid damage to the **LIGHTNING**. Set **STOP B** to "**2-STAGE**" and the type to "**LINKAGE / DISC**"

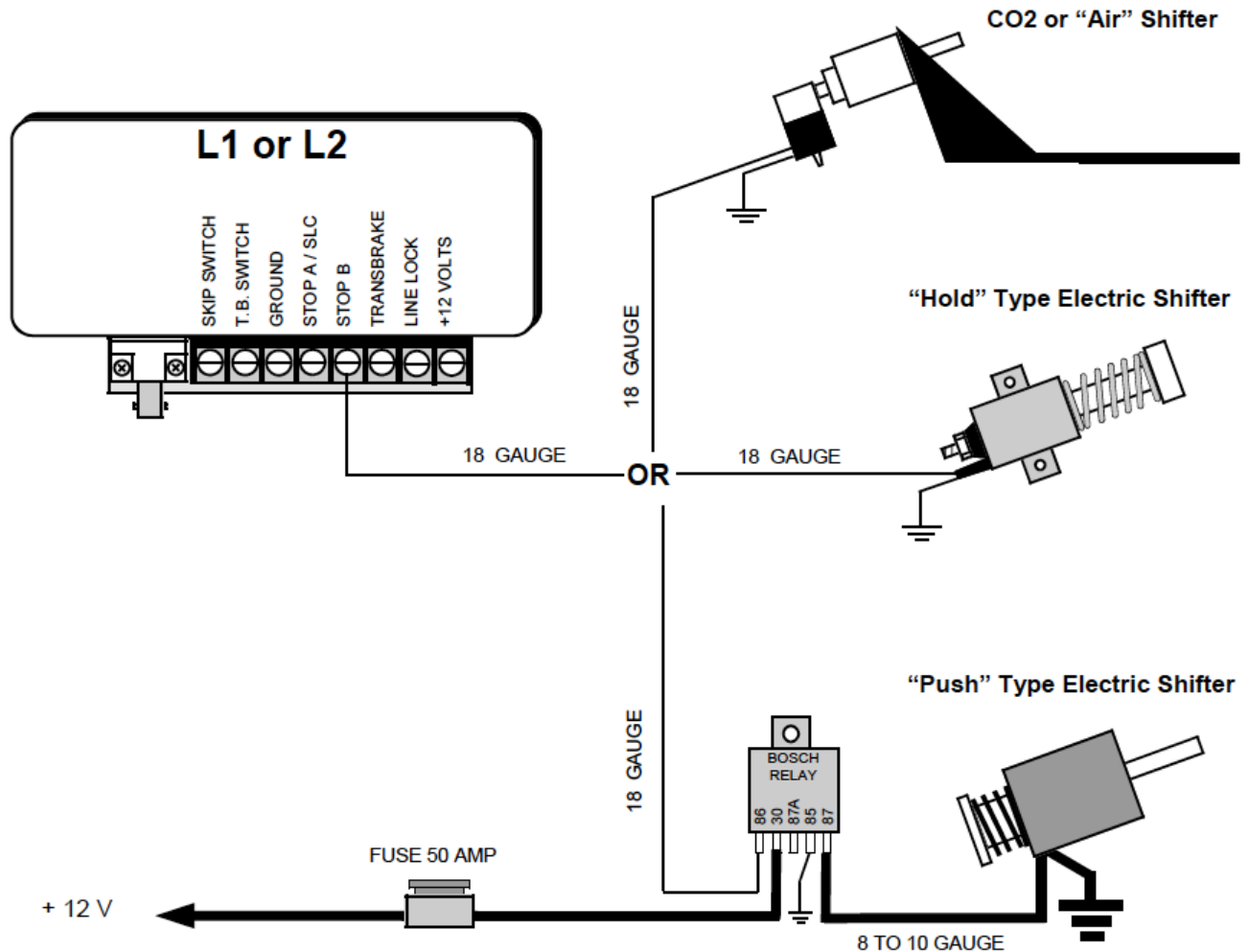

FACTORY SETTINGS AND PARAMETERS

PRO-FULL SETTING PARAMETERS: PRO MODE = P/F LIGHT ON FULL MODE = P/F LIGHT OFF			FACTORY SETTINGS	
ACCESS BUTTON	SETTING	RANGE	PRO	FULL
TBRK ↑ ↓ TBRK	DELAY DELAY 2 THEIR E.T. YOUR E.T. BOTTOM DELAY CROSS COMP SKIP UP / SKIP DOWN TB PAUSE TB LOCK OUT	0.000 to 1.999 sec. 0.000 to 1.999 sec. 00.00 to 19.99 sec. 00.00 to 19.99 sec. 0.00 to .299 sec. .000 to .099 sec. +.050 to -.050 sec. 0.000 to 1.999 sec. 00 to 19 seconds	.010 .010 10.90 9.90 .010 .015 -.010 .010 01	1.000 .500 10.00 9.00 .100 .015 -.010 .010 03
STOP A ↑ ↓ STOP A	THROTTLE STOP A, TIMER 1 THROTTLE STOP A, TIMER 2 THROTTLE STOP A, TIMER 3 THROTTLE STOP A, TIMER 4 T-STOP A TYPE T-STOP A CONTROL SLC START LINE CONTROL	0.000 to 9.999 sec. 0.000 to 9.999 sec. 0.00 to 19.99 sec. 0.00 to 19.99 sec Baseplate or Linkage/Disc 2-Stage, 4-Stage, Off TB Release, Timed, Prestage, Off	.300 1.500 3.00 3.00 LINK OFF OFF	1.000 2.000 3.00 3.00 LINK OFF TIMED
STOP B ↑ ↓ STOP B	THROTTLE STOP B, TIMER 1 THROTTLE STOP B, TIMER 2 THROTTLE STOP B, TIMER 3 THROTTLE STOP B, TIMER 4 T-STOP B TYPE T-STOP B CONTROL	0.000 to 9.999 sec. 0.000 to 9.999 sec. 0.00 to 19.99 sec. 0.00 to 19.99 sec Baseplate or Linkage/Disc 2-Stage, 4-Stage, Off	1.500 2.000 3.00 3.00 LINK 2-STG	1.000 2.000 3.00 3.00 LINK 2-STG