



413 West Elm Street • Sycamore, IL 60178
(866)248-6357 • (815)895-6786
www.autometer.com • service@autometer.com

The model ST-1 Shift Timer is designed for either applying power or removing power to devices on a drag race vehicle at a preprogrammed time into the run (0-9.99 sec). Typical applications include single CO2 or Electric shift, single stage throttle stops, single nitrous oxide, high gear retards, etc. Below are a few easy to understand wiring diagrams and output charts. Choose the diagram best suited for your particular application.

Ground= Chassis Ground: Good chassis ground (cage, frame or engine)

+12v = +12 volt power supply: Fused +12v supply from Master On-Off switch. 10 amp fuse maximum.

N.O. - Normally Open Terminal: This terminal has no power present until the timer times out. 10a max.

N.C. - Normally Closed Terminal: This terminal has +12v power present at all times until the timer times out. 10a max

TRIGGER = Trigger input: This terminal starts the timer at the launch of the car (start of race) and is tied to the transbrake

PULSE LENGTH Switches: Short = .5 second pulse Long = 17. second pulse

Under the 1/2-inch black plastic screw you'll find 2 micro switches that rock left to right. These switches control the PULSE LENGTH of the output terminals. Move both switches to the left for a SHORT 1/2 second (.5) pulse, and to the right for a LONG 17 second (17 .) pulse. After the pulse, the output will return to what it was before the pulse.

Sample Applications:

- If you are using a device such as an air/CO2 shifter, and you need a quick pulse of +12 volts to shift, and normally have no power on, use the N.O. (Normally Open) terminal and set both switches to the SHORT (left) setting.
- If you are using a device such as a Nitrous Oxide system, and you need a long pulse of +12 volts, use the N.O. (Normally Open) terminal and set both switches to the LONG (right) setting.

INSTALLATION

- Electric scoring type shifters such as the Dedenbear Solenoid Shifter require removal of +12 volts, use the N.C. (Normally Closed) terminal and only need a SHORT pulse.
 - Other brand "push" type shifter solenoids require a heavy duty relay (30amps or greater), and use the N.O. (Normally Open) terminal & SHORT pulse.
- 1) Mount the Shift Timer unit away from excessive heat, vibration, & ignition wires. Fasten with four (4) sheet metal screws, slightly compressing the rubber mounting grommets. It can be mounted in any position, even upside down or overhead locations. Mount the unit where it would be protected from fluids, such as rain, oil or brake fluid.
 - 2) Wire the unit as shown in the wiring diagrams. Use at least 14 gauge wire or larger. Install a fuse or circuit breaker to protect the box from possible damage from short circuits. Make sure you have a good ground connection, grounding to interior aluminum sheet metal is not reliable. Use a serrated washer on the chassis ground. The "Trigger" terminal should be wired to the transbrake solenoid wire after the delay box (if you're using one). This is so power is removed from the trigger when the car actually launches.

SEE REVERSE SIDE FOR WIRING DIAGRAMS

OPERATION

- 1) Set the pushbutton thumbwheels to the desired time during the run that you want the timer to operate.
- 2) Apply your transbrake on the starting line, when you launch the Shift Timer will start to time out.
- 3) When the preprogrammed time elapses, the N.O. (Normally Open) terminal will apply power and the N.C. (Normally Closed) terminal will remove power. After the pulse occurs, the output returns to its normal condition.
- 4) If you wish to make a pass without the Shift Timer operating, simply disconnect the Trigger terminal, and the unit will not know you're making a pass. (Setting the timer to 0.00 seconds will make it operate as soon as the car launches)

LIMITED 1 YEAR WARRANTY

DEDENBEAR Products, Inc. warrants to the consumer that all DEDENBEAR Products purchased from an Authorized DEDENBEAR Reseller will be free from defects in material and workmanship for a period of twelve (12) months from date of the original purchase. Products that fail within this 12 month warranty period will be repaired or replaced at DEDENBEAR's option, when determined by DEDENBEAR that the product failed due to defects in material or workmanship. This warranty is limited to the repair or replacement of parts in the DEDENBEAR Product and the necessary labor done by DEDENBEAR to effect the repair or replacement of the DEDENBEAR product. In no event shall DEDENBEAR's cost to repair or replace a DEDENBEAR Product under this warranty exceed the original purchase price of the DEDENBEAR Product. Nor shall DEDENBEAR Products, Inc. be responsible for special, incidental or consequential damages or costs incurred due to the failure of a DEDENBEAR Product. This warranty applies only to the original purchaser of the DEDENBEAR Product and is non-transferable. This warranty also applies only to DEDENBEAR Products purchased from an Authorized DEDENBEAR Reseller. All implied warranties shall be limited in duration to the said 12 month warranty period. Breaking the instrument seal, improper use or installation, accident, water damage, abuse, unauthorized repairs or alterations voids this warranty. DEDENBEAR disclaims any liability for consequential damages due to the breach of any written or implied warranty on all products manufactured by DEDENBEAR Products, Inc.

FOR SERVICE SEND TO: DEDENBEAR PRODUCTS, INC 413 W. Elm St. Sycamore, IL 60178 USA (866) 248-6357

Email: service@autometer.com

CUSTOMER SERVICE & TECH. SUPPORT: (866)248-6357 Mon-Fri 8am-5pm CST

OPERATION CHARTS

TIMER SET FOR 3.00 SECONDS
PULSE LENGTH SET FOR "SHORT"
(.5) SECONDS

The N.C.. terminal has power until the timer elapses, then removes power for 1/2 second, then applies power again.
The N.O.. terminal has no power until the timer elapses, then applies power for 1/2 second, then removes power again.

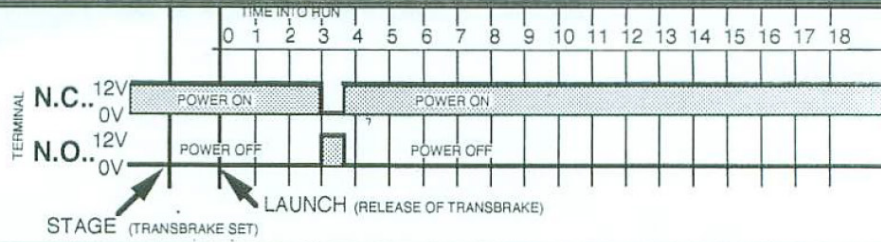

TIMER SET FOR 3.00 SECONDS
PULSE LENGTH SET FOR "LONG"
(17.) SECONDS

The N.C.. terminal has power until the timer elapses, then removes power for 17. seconds, then applies power again.
The N.O.. terminal has no power until the timer elapses, then applies power for 17. seconds, then removes power again.

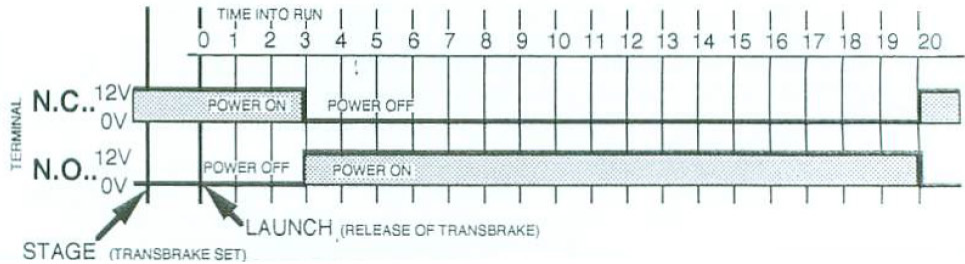

TYPICAL WIRING DIAGRAMS

Typical wiring diagram for electric "hold" or "spring" type solenoid shifters or CO2 air shifters: Set box for **SHORT** pulse.
For "baseplate" style throttle stops: Set box for **LONG** pulse. Maximum amperage rating for the ST-1 is 10 amps.

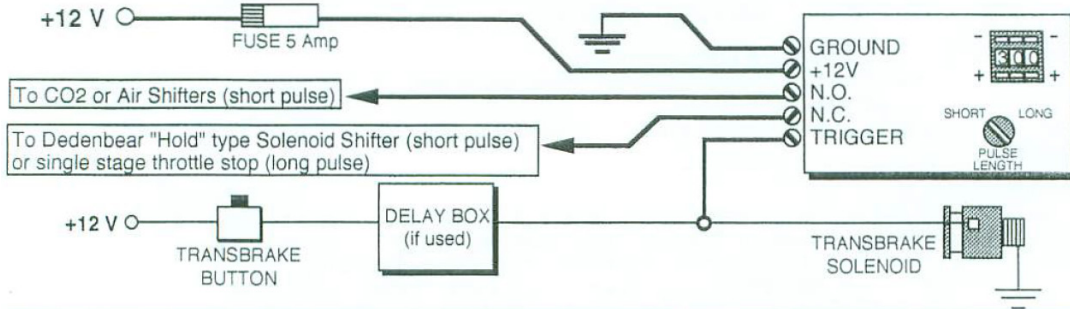

Typical wiring diagram for **NITROUS OXIDE** systems: Set box for **LONG** pulse.

