

**AIR LIFT**  
**PERFORMANCE**

# Kit 78655

BMW F30

*Rear Application*



## INSTALLATION GUIDE

For maximum effectiveness and safety, please read these instructions completely before proceeding with installation.

*Failure to read these instructions can result in an incorrect installation.*





## TABLE OF CONTENTS

<b>A. Introduction</b> .....	<b>2</b>
Notation Explanation .....	2
<b>B. Important Safety Notices</b> .....	<b>2</b>
<b>C. Installation Diagram</b> .....	<b>3</b>
Hardware List .....	3
<b>D. Installing the Air Suspension</b> .....	<b>4</b>
Removal of the Stock Suspension .....	4
Installing the Kit Components .....	6
Routing Air Lines .....	9
<b>E. Before Operating</b> .....	<b>10</b>
Setting the Ride Height .....	10
Torque Specifications .....	10
Suggested Driving Air Pressure and Maximum Air Pressure .....	10
Installation Checklist .....	11
Damping Adjustment .....	11
<b>Limited Warranty and Return Policy</b> .....	<b>12</b>



## A. Introduction

Air Lift Performance thanks you for purchasing the most complete, fully engineered high-performance air suspension made for the BMW F30. Read these installation instructions to correctly and safely set up the vehicle for a #lifeonair.

Air Lift assumes that the installer has the mechanical knowledge and ability to work on vehicle suspension systems and has basic tools necessary to complete the project. Special tools needed to complete the installation are noted on the *Installation Diagram* page.

Air Lift reserves the right to make changes and improvements to its products and publications at any time. For the latest version of this manual, contact Air Lift Performance at **(800) 248-0892** or visit **www.airliftperformance.com**.

An Air Lift Performance air management system is highly recommended for this product. Learn more at [air-lift.co/productlines](http://air-lift.co/productlines).

### NOTATION EXPLANATION

Hazard notations appear in various locations in this publication. Information which is highlighted by one of these notations must be observed to help minimize risk of personal injury or possible improper installation which may render the vehicle unsafe. Notes are used to help emphasize areas of procedural importance and provide helpful suggestions. The following definitions explain the use of these notations as they appear throughout this guide.



**DANGER**

INDICATES IMMEDIATE HAZARDS WHICH WILL RESULT IN SEVERE PERSONAL INJURY OR DEATH.



**WARNING**

INDICATES HAZARDS OR UNSAFE PRACTICES WHICH COULD RESULT IN SEVERE PERSONAL INJURY OR DEATH.



**CAUTION**

INDICATES HAZARDS OR UNSAFE PRACTICES WHICH COULD RESULT IN DAMAGE TO THE MACHINE OR MINOR PERSONAL INJURY.

### NOTE

*Indicates a procedure, practice or hint which is important to highlight.*

## B. Important Safety Notices



**WARNING**

DO NOT INFLATE AIR SPRINGS WHILE OFF OF THE VEHICLE. DAMAGE TO ASSEMBLY MAY RESULT AND VOID WARRANTY.



**CAUTION**

DO NOT WELD TO OR MODIFY PERFORMANCE STRUTS/SOCKS IN ANY WAY. DAMAGE TO UNIT MAY OCCUR AND WILL VOID WARRANTY.

# C. Installation Diagram

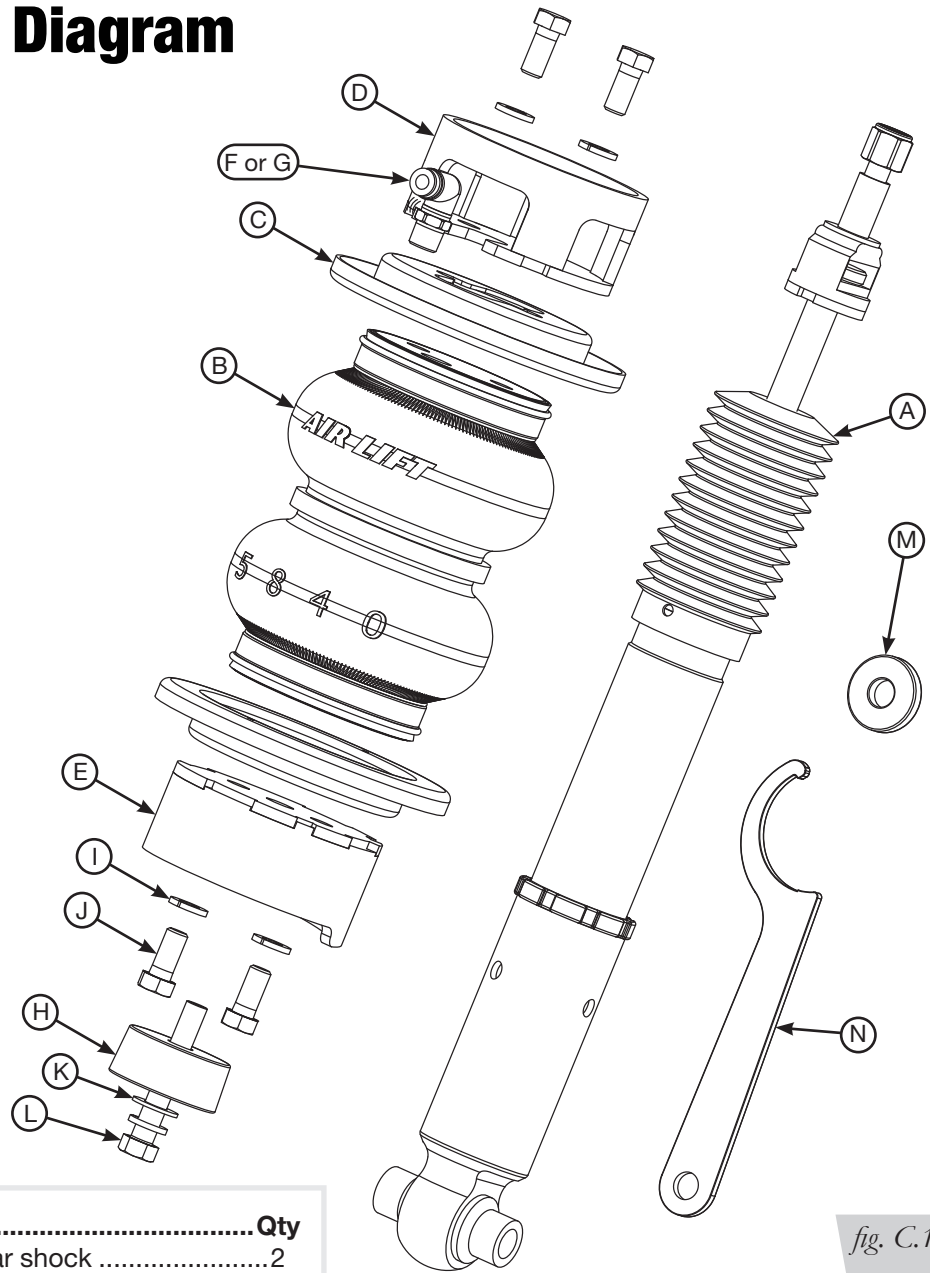


fig. C.1

## HARDWARE LIST

Item	Part #	Description.....	Qty
A	26844	BMW F30 rear shock .....	2
B	58535	Air spring .....	2
C	11803	Roll plate .....	4
D	07969	Upper bracket .....	2
E	03969	Lower bracket .....	2
F*	21851	Union, 1/4" MNPT X 3/8" elbow .....	2
G	21779	Union, 1/4" MNPT X 1/4" elbow .....	2
H	13993	Centering spacer.....	2
I	18427	3/8" Lock washer .....	10
J	17203	3/8"-24 x 7/8" Hex bolt .....	8
K	18444	3/8" Flat washer .....	2
L	17454	3/8"-24 x 2 1/2" Hex cap screw.....	2
M	13994	Toe link spacer .....	2
N		Spanner wrench .....	1

\*Union, 1/4" MNPT X 3/8" elbow are NOT included in this kit, but are available as a special order.



Missing or damaged parts? Call Air Lift customer service at (800) 248-0892 for a replacement part.

# D. Installing the Air Suspension

## REMOVAL OF THE STOCK SUSPENSION

### NOTES

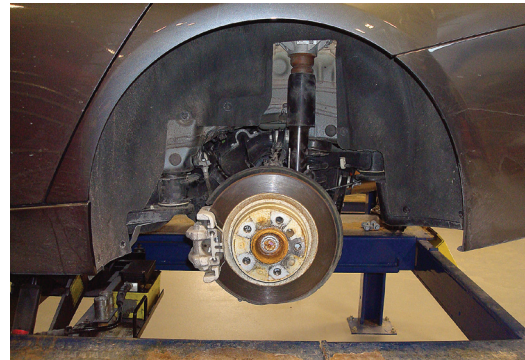
See Important Safety Notices on page 2.

BMW recommends replacing all loosened factory fasteners – other than wheel bolts.

1. Elevate and support the vehicle using its approved lifting points. Remove the front wheel and support the hub assembly (Figs. D.1 & D.2).

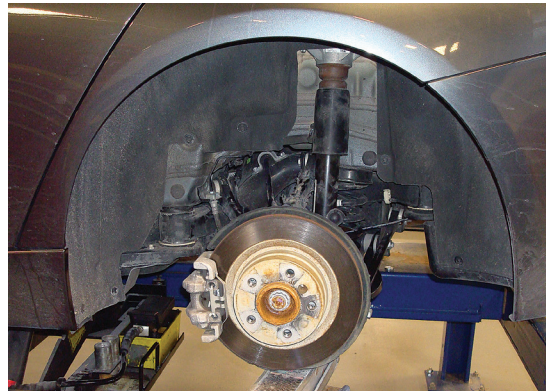


*fig. D.1*

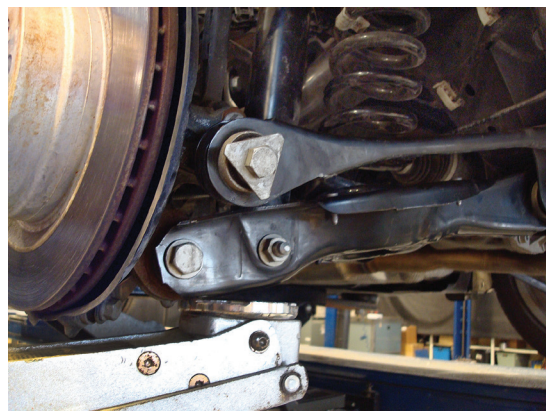


*fig. D.2*

2. Support the lower control arm (Figs. D.3 & D.4).



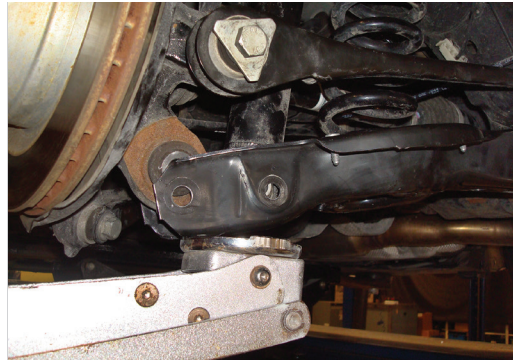
*fig. D.3*



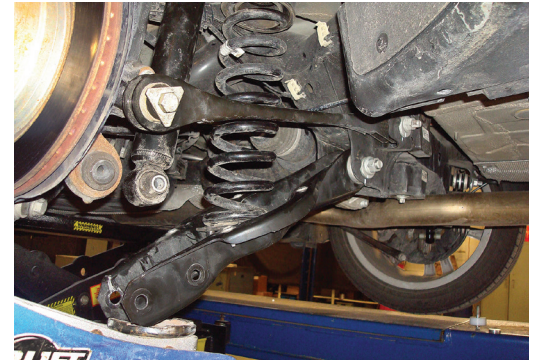
*fig. D.4*

 **DANGER**

THE COIL SPRING IS UNDER COMPRESSION. THE COIL SPRING SHOULD BE REMOVED USING FACTORY PRESCRIBED GUIDELINES. SUPPORT THE HUB AND UNBOLT THE LOWER SHOCK EYE. REMOVE THE OUTER CONTROL ARM TO HUB BOLT (FIGS. D.5 & D.6).



*fig. D.5*

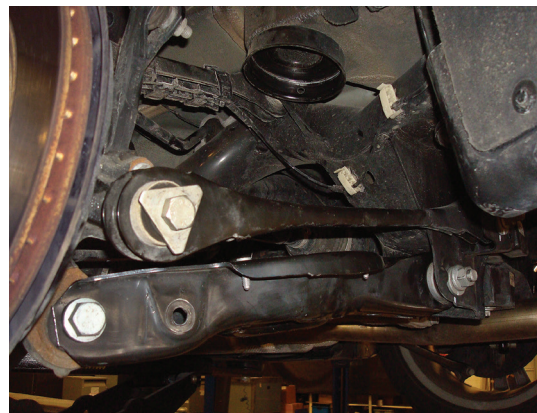


*fig. D.6*

3. Remove the coil spring (Fig. D.7). Reattach the control arm to the hub. Do not torque the bolt at this time (Fig. D.8).



*fig. D.7*



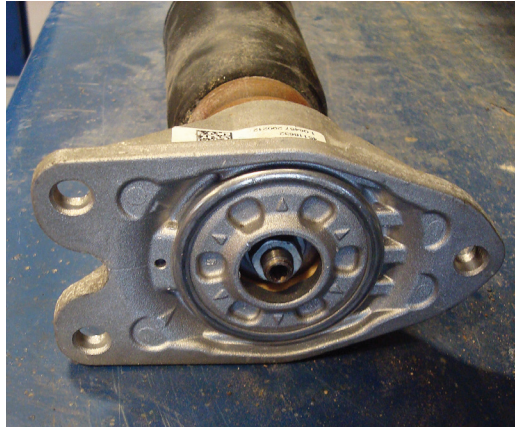
*fig. D.8*

4. Unbolt the shock assembly from the chassis (Fig. D.9).



*fig. D.9*

5. Remove the shock upper mount from the shock rod (Figs. D.10 & D.11).

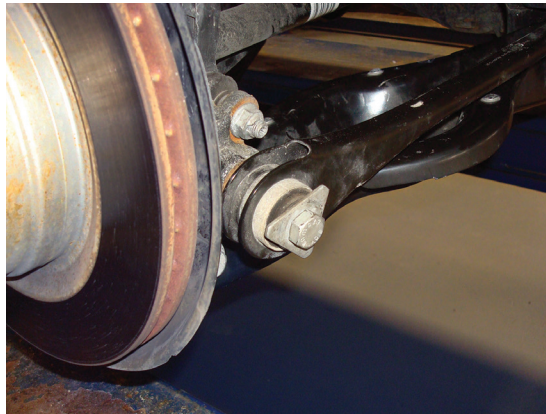


*fig. D.10*



*fig. D.11*

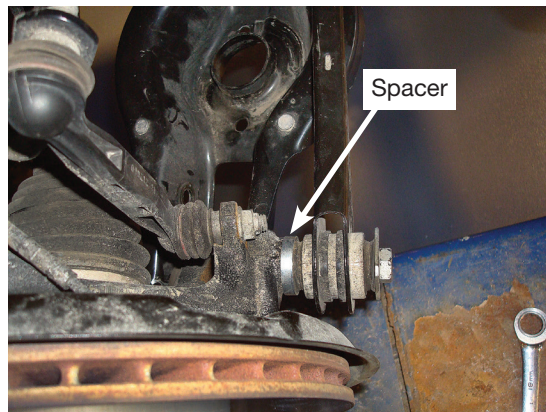
6. Unthread the outer toe link bolt and remove from hub (Fig. D.12).



*fig. D.12*

## INSTALLING THE KIT COMPONENTS

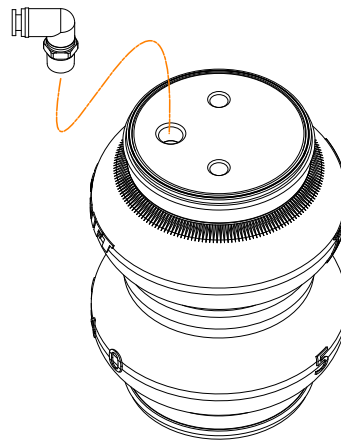
1. Install spacer between the toe link and hub. Reinstall bolt. Torque at desired ride height (Fig. D.13).



*fig. D.13*

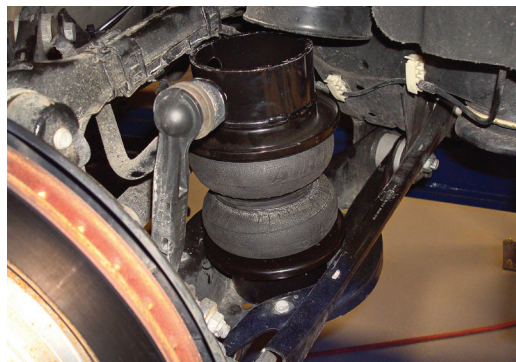


2. Apply thread sealant to the fitting threads. Tighten the fitting into the air spring 1 3/4 turns beyond hand-tight (Fig. D.14).



*fig. D.14*

3. Place the air spring assembly into the lower control arm. Rotate the assembly until the lower bracket is aligned with the coil spring seat (Figs. D.15 & D.16).



*fig. D.15*



*fig. D.16*

4. Insert the supplied centering spacer (H) through the bottom of the control arm and bolt the air spring assembly to the spacer (H) with hex cap screw (L) and lock washer (I) Torque to 27Nm (20 lb.-ft.) (Figs. D.17 & D.18).



*fig. D.17*

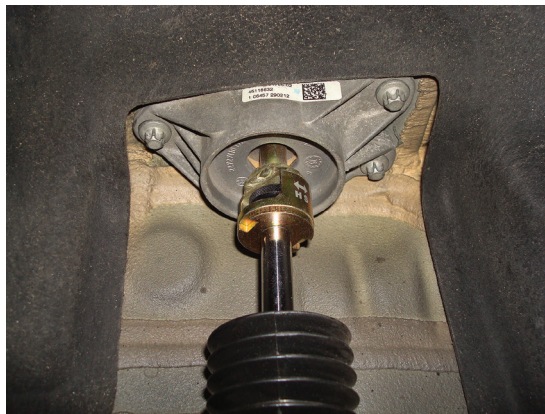


*fig. D.18*

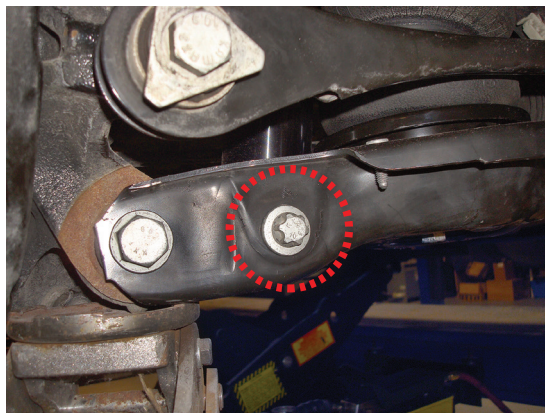
5. Attach upper shock mount to the supplied shock. Torque the rod nut to 38Nm (28 lb.-ft.) (Fig. D.19).

*fig. D.19*

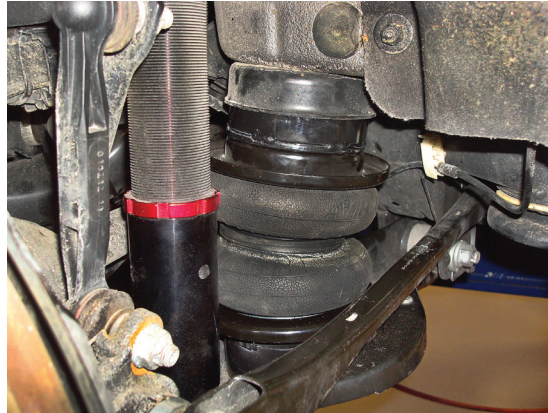
6. Align the shock upper mount to the chassis and install the three upper mount bolts. Torque to 28Nm (21 lb.-ft.) (Fig. D.20).

*fig. D.20*

7. Lift the hub assembly, aligning the shock eye, and install the lower shock bolt. Torque at desired ride height (Fig. D.21).

*fig. D.21*

8. Align the upper bracket into upper spring seat (Fig. D.22).



*fig. D.22*

### ROUTING THE AIR LINES

1. Fully compress the suspension using a jack. With the suspension compressed, review the best routing for the air line that is clear of all suspension components and axle.
2. Routing should also allow for the suspension to extend without kinking or pulling the line tight or rubbing on other components. Following the brake line routing is often a good place to start. Check clearances to all other components.

# E. Before Operating

## SETTING THE RIDE HEIGHT

Please refer to the User Guide supplied with this kit to set up the suspension.

Torque Specifications		
Location	Nm	Lb.-ft.
Air spring bolts	27	20
Shock rod nut	38	28
Air fittings (with thread sealant)	1 3/4 turns beyond hand tight	
Shock upper mount to chassis	28	21
Shock lower mount bolt	100 + 90 degrees	74 + 90 degrees
Lower control arm to hub	165 + 90 degrees	122 + 90 degrees
Lower control arm to subframe	165 + 90 degrees	122 + 90 degrees
Toe link to hub	100 + 90 degrees	74 + 90 degrees
Toe link to subframe	100 + 90 degrees	74 + 90 degrees
Shock locking collar	1/4 turn beyond hand tight	
Wheel bolts	140	103

*Table 1*

Suggested Driving Air Pressure	Maximum Air Pressure
<b>90-110 PSI (6.2-7.6BAR)</b>	<b>150 PSI (10.3BAR)</b>
FAILURE TO MAINTAIN ADEQUATE MINIMUM PRESSURE (OR PRESSURE PROPORTIONAL TO LOAD) MAY RESULT IN EXCESSIVE BOTTOMING OUT AND <b>WILL VOID THE WARRANTY.</b>	

*Table 2*

## INSTALLATION CHECKLIST

- Clearance** — Inflate the air springs to 75-90 PSI (5.2-6.2BAR) and make sure there is at least 1/2" (13mm) clearance from anything that might rub against the air spring. This should be checked with the air spring fully inflated and fully deflated.
- Leak** — Inflate the air springs to 75-90 PSI (5.2-6.2BAR) and check all connections for leaks. All leaks must be eliminated before the vehicle is road tested.
- Heat** — Be sure there is sufficient clearance from heat sources, at least 6" (152mm) from air springs and air lines. If a heat shield was included in the kit, install it. If there is no heat shield, but one is required, call Air Lift customer service at **(800) 248-0892**.
- Fastener** — Recheck all bolts for proper torque.
- Road** — Inflate the air springs to recommended driving pressures (Table 2). Drive the vehicle 10 miles (16km) and recheck for clearance, loose fasteners and air leaks.
- Operating instructions** — If professionally installed, the installer should review the operating instructions with the owner. Be sure to provide the owner with all paperwork that came with the kit.

## DAMPING ADJUSTMENT

Suspension damping is a matter of compromise. Setting it too stiff will make the ride feel jarring. In addition, if the suspension is too stiff, the tires will lose contact with the road, reducing control and power delivery. On the other hand, if the suspension is too soft, the car can experience brake dive and excessive bouncing. The sweet spot lies somewhere in the middle. Air Lift dampers have a range of adjustment, which allows the driver to tune the ride and handling to his or her preferences.

Air Lift recommends damper and air pressure settings for every vehicle kit, but it is impossible to consider every situation. For example, even though Air Lift kits replace the dampers and springs, vehicles with sport-tuned suspensions might have stiffer bushings, larger anti-roll bars, bigger wheels, wider tires, etc. These settings may need to be adjusted to different vehicles and driving characteristics.

1. The dampers in this kit have 30 settings, or "clicks," of adjustable compression and rebound damping characteristics. Damping is changed through the damper rod using the adjuster (Fig. E.1).
2. Turn the adjuster clockwise (H) and the damping settings are hardened, reducing oscillations and body motion. Turn the adjuster counterclockwise (S) and the damping is softened.
3. Each damper in this kit is preset to "-16 clicks." This means that the damper is adjusted 16 clicks away from full stiff, which starts at 0. Counting up from full stiff is the preferred method of keeping track of, or setting, damping. This setting was developed on a 2012 BMW 328i.

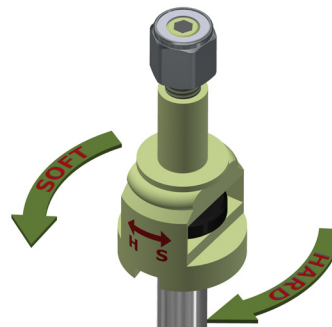


fig. E.1

## Limited Warranty and Return Policy

Air Lift Company provides a 1-year limited warranty to the original purchaser of Air Lift Performance damper kits from the date of original purchase, that the products will be free from defects in workmanship and materials when used on vehicles as specified by Air Lift Company and under normal operating conditions, subject to the requirements and exclusions set forth in the full Limited Warranty and Return Policy that is available online at [www.airliftperformance.com/warranty](http://www.airliftperformance.com/warranty).

For additional warranty information contact Air Lift Company customer service.

Air Lift Company reserves the right to make changes and improvements to its products and publications at any time. For the latest version of this manual, contact Air Lift Company at (800) 248-0892 or visit [www.airliftperformance.com](http://www.airliftperformance.com).



## Need Help?

Contact Air Lift Company customer service department by calling (800) 248-0892. For calls from outside the USA or Canada, dial (517) 322-2144.



Connect by searching for **Air Lift Performance** #LifeonAir



*Thank you for purchasing Air Lift Performance products!*



Air Lift Performance • 2727 Snow Road • Lansing, MI 48917 or P.O. Box 80167 • Lansing, MI 48908-0167  
Toll Free (800) 248-0892 • Local (517) 322-2144 • Fax (517) 322-0240 • [www.airliftperformance.com](http://www.airliftperformance.com)

Printed in the USA  
MB-0120

California: ⚠️WARNING: Cancer and Reproductive Harm - [www.P65Warnings.ca.gov](http://www.P65Warnings.ca.gov)